

LINK

LINK
LIFTABLE
SUSPENSIONS

INSTALLATION INSTRUCTIONS

MODEL 6000

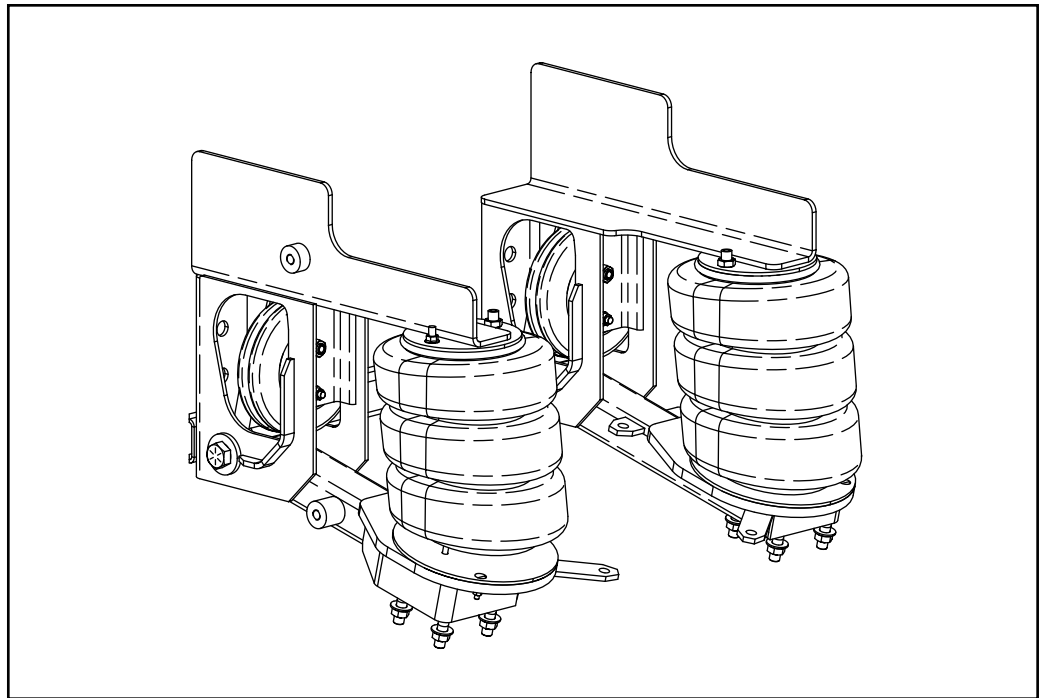

*Link Mfg. Ltd.
223 15th St. NE
Sioux Center, IA USA
51250-2120*

*(712) 722-4874
Fax (712) 722-4876*

**QUESTIONS?
CALL CUSTOMER
SERVICE
1-800-222-6283**

AVAILABLE IN 13.2K, 16K AND 20K CAPACITIES

IMPORTANT: UPON RECEIVING YOUR LINK SUSPENSION, INSPECT IT FOR DAMAGED OR MISSING PARTS. CAREFULLY READ AND UNDERSTAND THIS INSTRUCTION MANUAL BEFORE INSTALLING THE SUSPENSION AND THE TASK WILL BE MUCH EASIER.

INSTALLATION

1. Determine the distance the liftable axle center will be located from an existing axle center. This is the axle spacing (Fig. 1).
2. A reference point is needed to locate the liftable suspension on the vehicle frame rails. The distance from the existing axle center to the suspension is the frame reference point dimension (Fig. 1). **NOTE:** A pusher axle is a liftable axle installed in front of the drive axle(s). A tag axle is a liftable axle installed behind the drive axle(s).

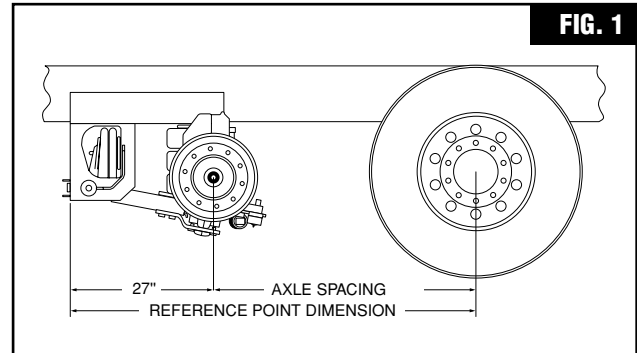

- a. To determine the reference point dimension on the vehicle frame for a pusher **add** 27" to the axle spacing, for a tag **subtract** 27" (Fig. 1).
3. Mark the location of the reference point on both vehicle frame rails. Do this by measuring the reference point dimension from the existing axle center (Fig. 2).
 - a. It is possible that the existing axle is slightly out of square due to small inaccuracies in the springs, arms and bushings in the existing suspension. Because of these inaccuracies, it may be necessary to adjust the reference point marks on the vehicle frame rails. Do this by measuring from the reference point mark on the frame rails to a suspension mounting bolt (Fig. 3). (The bolt holes in the frame rails are accurately located.)
 - b. After measuring on both frame rails, compare the measurements. Adjust the reference point marks to the larger of the two measurements if there is a difference from right to left frame rails.



4. The suspension frame brackets will require a mounting area on the frame rails 29.5" long by 5 5/8" high. At this time remove any bolts or brackets that may be in this area. Bolts that would pass through the edge of the frame bracket may remain in place and the frame bracket should be notched for clearance (Fig. 4). **NOTE:** A set of extended forks for your forklift will help with installation. If you don't have a forklift, two floor jacks will do.

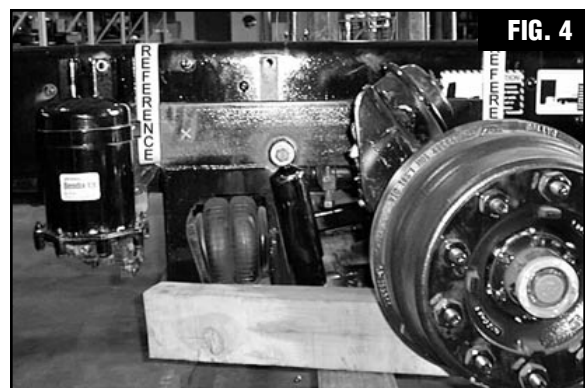
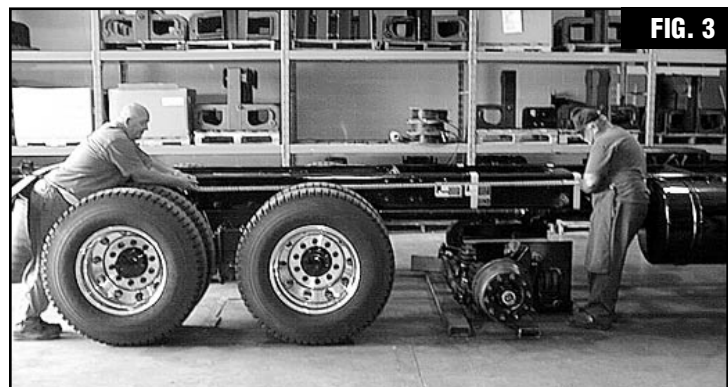

CAUTION: Any cutting of the frame bracket must be confined to within one inch of the edges and only that which is necessary for clearance. Any cutting or modification to the Link suspension other than that described above, done without the written approval of Link engineering, will void the warranty.

5. Slide the liftable suspension under the vehicle in the approximate location for installation (Fig. 5). Raise up to the truck frame using forklift or floor jacks as discussed in the previous note.

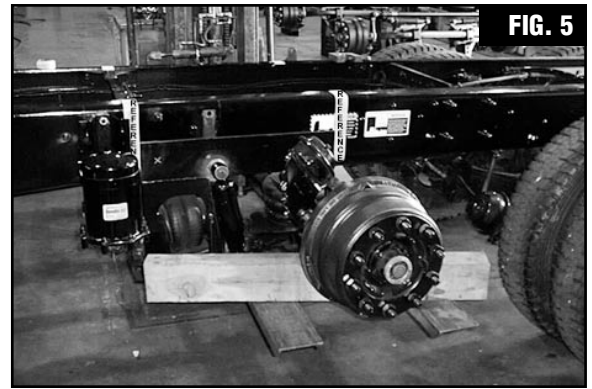

6. Position and clamp the suspension frame bracket to the vehicle frame rails, aligning the front edge of the frame brackets to the reference points on the vehicle frame rails (Fig. 6).
NOTE: Be sure the frame brackets are clamped tightly against the sides and bottom of the frame rails.

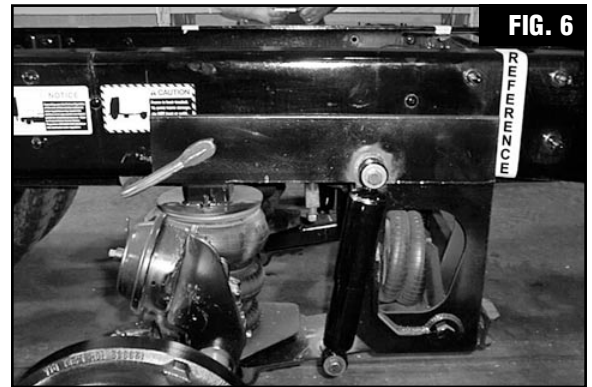

- a. If the bottom of the frame rails are tapered, a wedge is necessary (Fig. 7). In order to keep the frame bracket parallel to the top of the truck frame, the wedge must completely fill the void caused by the tapered portion and be made of 1/4" thick steel. Weld the wedge to the frame bracket at both ends and center. Use a minimum of 1/4" fillet 2" long.

7. Check for drive shaft clearance. With a tandem axle suspension, raise the rear drive axle until the front drive tires of the tandem are off the ground (Fig. 8).

- a. At this point, the drive shaft is at the most extreme angle and is the closest it can get to the liftable axle and tie-rod. (Single drive axle vehicles require raising the frame until the drive tires are off the ground.) With the drive shaft at its lowest position, raise the liftable suspension to the maximum lift position with a jack under the axle center.

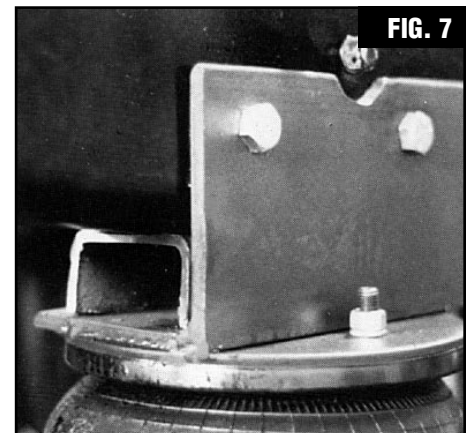

(continued on next page...)



(continued from previous page...)

- b. Check for clearance between any vehicle components and the liftable axle and suspension. One inch clearance is required. In the event of tie-rod to drive shaft interference, a dropped tie-rod is available (Fig. 9 & 10).

IMPORTANT: Do not pressurize ride air springs until after tires are installed or unless the axle is supported on jack stands. **Over-extension can crush lift air springs.**

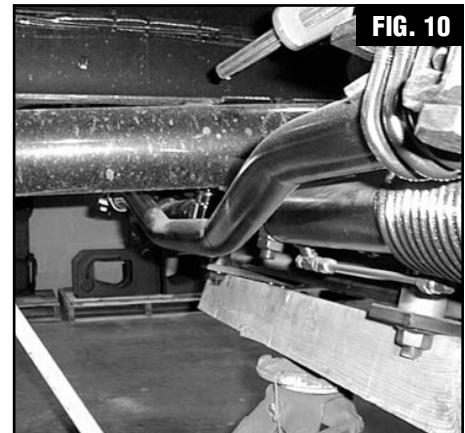
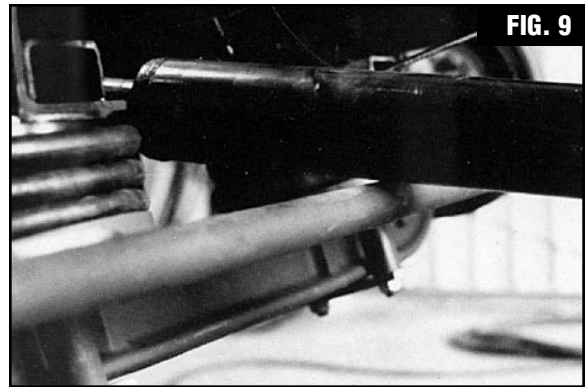

8. The recommended mounting bolt pattern for each frame bracket is a minimum of six 5/8" grade 8 flange head bolts with nuts as shown in Fig. 11. A tapered frame may require moving one or two of the bolts higher on the frame bracket (Fig. 11). Any existing holes in frame rails may be used as well. Torque 5/8" grade 8 bolts to 245 ft. lbs. If a shock absorber is used, the top shock absorber bolt may be used as one of the six.
9. Torque 3/4" axle mounting bolt nuts to 425 ft. lbs. (except flat head socket cap screws on PB6000A/S, 7000, 8001 and 8002 to 250 ft. lbs.) Torque 1 1/8" pivot bolt nut to 480 ft. lbs. (Grade 5 with Antiseize applied). Re-torque all nuts and bolts after 30 days.
10. Toe in at hubs should be 0 to +1/16". Toe in at tires should be 0 to +3/16".

11. Follow the schematics **closely** for installation of the controls. Safety protection valve (HS #10401B or equivalent) must be installed at the air tank before the feed to the controls. The exhaust valve is to be installed for down air springs. 3/8" D.O.T. approved fittings and tubes required.
12. It is required to use a brake relay inline for the air supply to the brake chambers on the liftable axle. (Instructions included in brake relay inline kit)
13. Adjust steering stops by driving vehicle forward with axle down and no less than 30 psi on ride springs, sharply to the right. Check stops for contact (1/8" clearance), also check hydraulic damper and air centering device for maximum travel or bottoming out. Adjust stops accordingly. Repeat for left hand turn.



14. Adjust steering stabilizer: loosen u-bolts holding the steering stabilizer bracket to the tie-rod with the axle down and 30 psi on ride air springs. Drive the vehicle straight ahead and stop. With vehicle in straight ahead position, tighten u-bolts to 25 ft. lbs. torque.

15. **CAUTION: MANDATORY LUBRICATION** (Fig. 12):
- Grease kingpin and tie-rod bi-monthly
 - Grease and repack bearings quarterly
 - Before operating, vehicle hub cavity must be filled to proper level with an approved wheel bearing lubricant compatible with gear lube API Service Class GL-5
 - Wheel bearings have been oil dipped for axle shipping only with 85-90W Hypoid gear oil that meets military specifications, MIL-L-2105C with API Service Class GL-5.

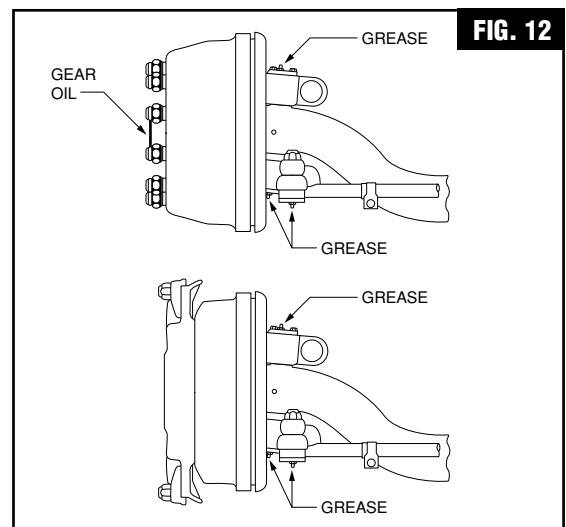

AXLE CAPACITY VS. AIR PRESSURE CHART

1. Measure the height of your air spring to determine the air spring height.*
2. Find that height on chart, considering suspension, model, and part no. of air bag.
3. Finding the desired load capacity determines the air pressure for the air spring.
4. Truck should be scaled to accurately set desired load.

*Air Spring Height - Defined as the distance from the top air spring plate to the bottom air spring plate, when measured at the side center position of the air spring, in the loaded condition.

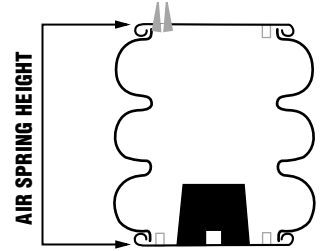

MODEL 6000

HEIGHT	11"	11"	12"	12"	13"	13"	14"	14"	15"	15"		
--------	-----	-----	-----	-----	-----	-----	-----	-----	-----	-----	--	--

PART #	8039	7850	8039	7850	8039	7850	8039	7850	8039	7850		
--------	------	------	------	------	------	------	------	------	------	------	--	--

AXLE FORCE (CAPACITY)	20,000 #		92		96		101		107		114		
	19,000#		88		92		96		101		106		
	18,000#		84		88		91		96		102		
	17,000#		79		83		87		90		97		
	16,000#		75		79		81		85		93		
	15,000#		69		74		77		81		88		
	14,000#		64		68		72		77		82		
	13,000#	94	61	99	65		71		72		76		
	12,000#	87	56	92	59	98	61		65		70		
	11,000#	80	50	86	55	91	56	98	60		65		
	10,000#	73	48	78	50	84	51	90	55	97	60		
	9,000#	66	42	70	44	74	47	80	49	90	53		
	8,000#	59	38	63	40	69	43	74	46	80	48		
	7,000#	52	33	56	34	59	36	64	40	72	44		
	6,000#	45	28	48	30	51	32	55	34	61	38		
	5,000#	37	22	40	24	44	27	48	30	53	32		
	4,000#	30	19	33	20	35	22	38	24	43	26		

MODEL 6000 IDENTIFICATION WORKSHEET

Using the following steps and chart, select the proper frame bracket part no. Use the loaded tire radius and loaded frame height to insure the correct suspension operating angle and a nominal lift of 10".

1. Locate the loaded tire radius in column **A**.
2. Locate the loaded frame height in column **C**.
3. Using a straight edge, draw a line connecting these two points.
4. Locate the intersection of the line drawn and the frame bracket Part No. in column **B**.
5. If the intersection falls between two part numbers, choose the smaller model number.
6. For application beyond the range of this chart, contact sales or engineering.

NOTE: This chart is prepared for use with Link model 6000C suspension with Westport 13,200# axle having 5-5/8" offset (drop). When the axle offset is less than 5-5/8", add the difference to the loaded tire radius. When the offset is greater than 5-5/8", subtract the difference from the loaded tire radius.

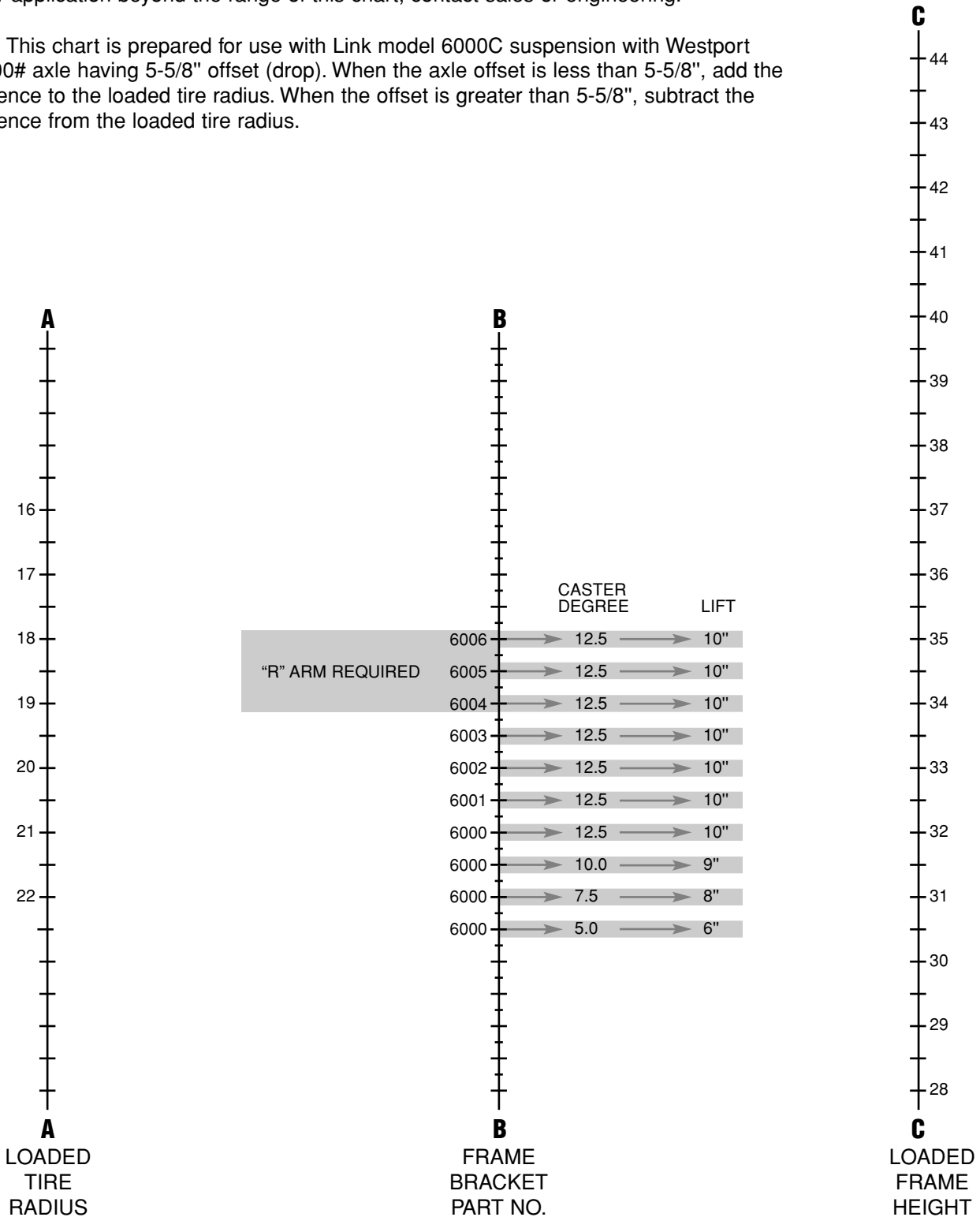

TROUBLESHOOTING CHART

TROUBLE	PROBABLE CAUSE	REMEDY
Shimmy	Improper Caster	1. Check with truck loaded and on a level surface, put angle indicator on axle mounting plate. Angle should not be less than 3° for proper tracking. A) Check spring on truck to see if they are weak or broken, if so, replace them and redo step one. B) Install smaller tires on liftable axle if possible and redo step 1. C) Call factory for assistance.
	Excessive Toe In or Out	1. Check toe in or out. A) Adjust toe in to 0" to + 3/16" at tires or 0 to + 1/16" at hubs.
	Tires out of balance	1. Check A) Balance tires. B) Replace tires.
	Steering Stabilizer	1. Check for visible damage. A) If damaged, replace 2. Check tension in both directions on tie rod as it should center itself. B) If weak in one direction, replace. 3. Check for damping in stabilizer. You should not be able to move tires back and forth rapidly. C) If stabilizer appears to be soft, replace it.
	Worn Tie Rod Ends	1. Check for excessive wear. A) If worn or damaged, replace.
	Worn King Pins	
Worn Rubber Bushings in Arm Ends at Pivot Point		
Axle will not stay up	Loose Air Fittings	Check and retighten.
	Damaged Air Lines	1. Check for excessive wear. A) If worn or damaged, replace.
	Damaged or Worn Air Springs	
Axle will not raise when the transmission is in reverse	Relay not grounded	Install ground wire from frame to relay.
	4-way Solenoid Valve not working	1. Check for excessive wear. A) If worn or damaged, replace.



LINK MANUFACTURING, LTD.
223 15TH ST. NE
SIOUX CENTER, IA 51250
1-800-222-6283