

LINK[®] **Cabmate**[®] Cab Air Suspension

KWE90112-B (2546-A000)

PARTS LIST



*Link mfg. Ltd.
223 15th St. N.E.
Sioux Center, IA USA
51250-2120*

*(712) 722-4874
Fax (712) 722-4876*

**QUESTIONS?
CALL CUSTOMER
SERVICE
1-800-222-6283**

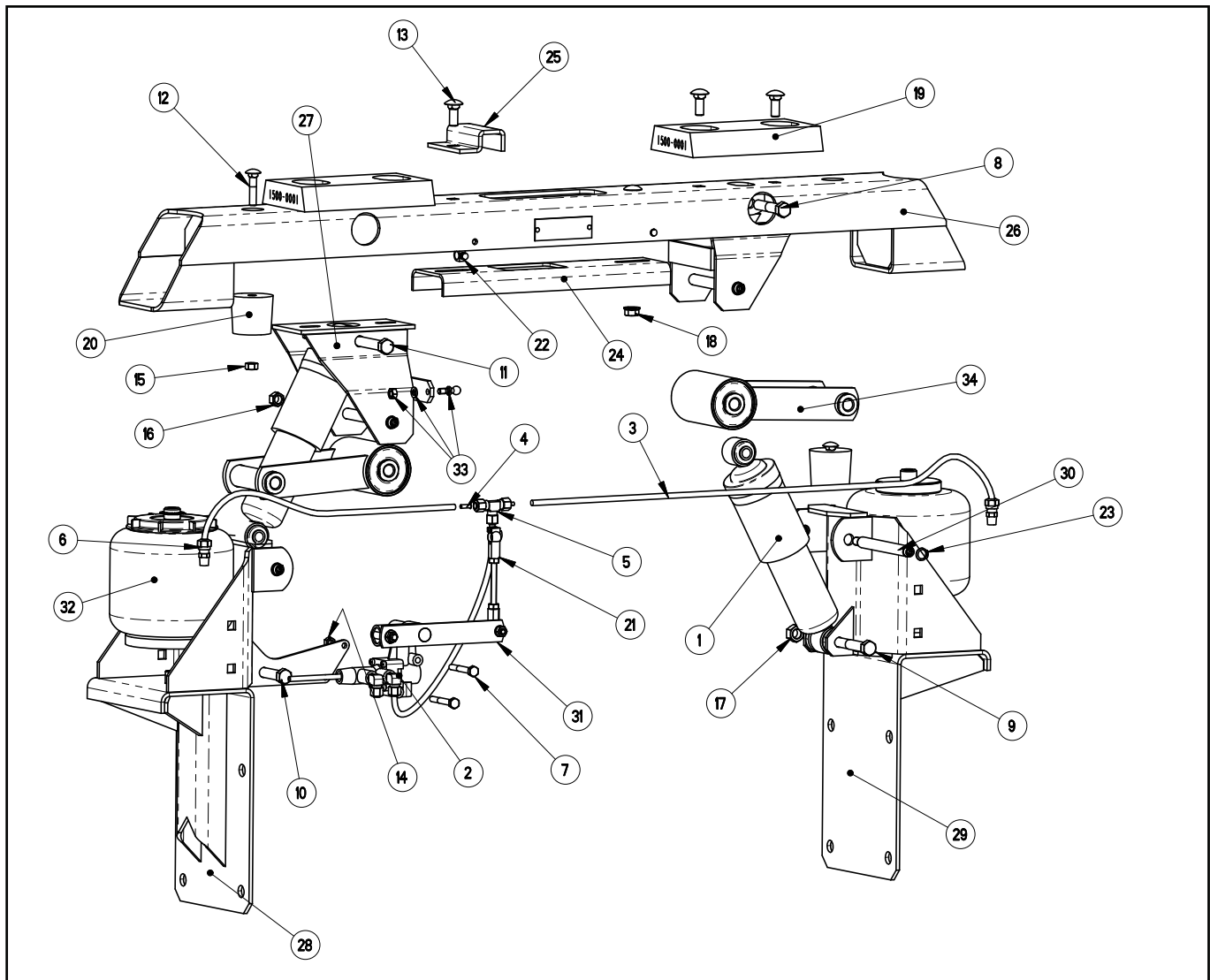

CABMATE[®] MODEL 2546-A000 PARTS LIST

ITEM	PART NO.	DESCRIPTION	QTY	ITEM	PART NO.	DESCRIPTION	QTY
1	1202K064	SHOCK ABSORBER	2	18	1480-1201	3/8 UNC TOP LOCK FL NUT (GR F)	6
2	1301-0020	VALVE-CONTROL, HEIGHT	1	19	1500-0001	MOUNT PAD	2
3	1302-0090	AIRLINE-NYLON, .250 O.D., BULK	4.5 ft	20	1500-0070	BUMPER-JOUNCE, 1.75	2
4	1302-1038	.25 TUBE SUPPORT	4	21	1500-0248	LINKAGE-VALVE, HEIGHT CONTROL (4.25)	1
5	1302-1083	UNION TEE, 1/4 TB	1	22	1500-0302	CLIP-LATCHING	2
6	1302-4069	CONNECTOR, 1/4 TB 1/8 M-NPT, DOT	2	23	1500-0360	RING-RETAINING, EXTERNAL	4
-	1350-0000	KIT-PROTECTION, PRESSURE	1	24	2500-2100	LATCH PLATE	1
7	1401-0816	1/4 X 2 UNC HEX CAP SCR (GR 5)	2	25	2545-0002	PUSH-OFF PAD	1
8	1403-1418	7/16 X 2 1/4 UNF HEX CAP SCR (GR 5)	1	26	2546-1000	UNIT TOP	1
9	1403-1422	7/16 X 2 3/4 UNF HEX CAP SCR (GR 5)	1	27	2546-2000	ADJUSTABLE HINGE ARM MOUNT	1
10	1403-1424	7/16 X 3 UNF HEX CAP SCR (GR 5)	1	28	2546-3000	UNIT BOTTOM-DRIVER	1
11	1403-1428	7/16 X 3 1/2 UNF HEX CAP SCR (GR 5)	1	29	2546-4000	UNIT BOTTOM-PASSENGER	1
12	1435-1012	5/16 X 1 1/2 UNC RND HD SQ NK BOLT (GRADE 5)	2	30	2990-0032	4.25 HINGE ARM BOLT	4
13	1435-1208	3/8 X 1 UNC RND HD SQ NK BOLT (GRADE 5)	6	31	2990-0500	ARM-VALVE (4.00 STD)	1
14	1476-0800	1/4 UNC HEX CTR LOCK NUT (GR B)	2	32	2991-0013	KWE90112-B AIR SPRING SERVICE KIT	1
15	1476-1000	5/16 UNC HEX CTR LOCK NUT (GR B)	2	33	2991-0026	KIT-PIVOT BALL	1
16	1476-1201	3/8 UNC HEX TOP LOCK NUT (GR C)	4	34	2992-2008	HINGE ARM, TYPE B (6.000)	2
17	1477-1400	7/16 UNF HEX CTR LOCK NUT (GR B)	4				

CABMATE MODEL[®] 2546-A000

WARNING: FOR SAFTY PURPOSES THE CABMATE MUST BE SUPPLIED FROM A PRESSURE PROTECTED CIRCUIT. IN THE EVENT OF AN AIR LEAK IN THE CAB SUSPENSION, FAILURE TO PROVIDE A PRESSURE PROTECTED CIRCUIT MAY CAUSE LOSS OF AIR PRESSURE TO VITAL SYSTEMS ON THE VEHICLE.

WARNING: LOSS OR APPLICATION OF AIR PRESSURE TO CABMATE WILL CAUSE SUDDEN MOVEMENT OF THE CAB. PRIOR TO INSTALLING OR PERFORMING MAINTENANCE, BLOCK UP THE CABMATE TO PREVENT THE POSSIBILITY OF INJURY.

HEIGHT ADJUSTMENTS

Measure the design height of the air spring(s). The height should be 5 7/8 inches ± 1/16. To change the height, disconnect one end of the valve linkage and adjust accordingly. Tighten the lock nuts on the valve linkage. The valve arm has a slot which will allow for coarse adjustment also. (See diagram below.)

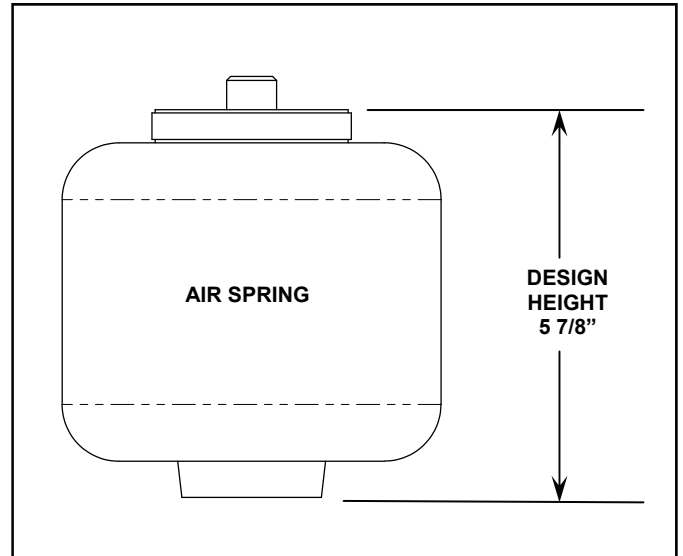
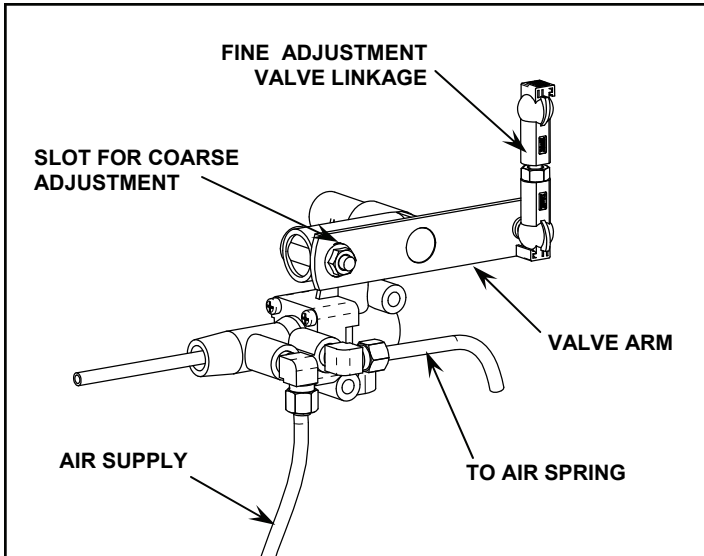

MAINTENANCE

CABMATES need no lubrication and little maintenance. The following components should be checked at the time the truck is being serviced. However, immediate corrective action should be taken if a serious malfunction occurs.

COMPONENT	POSSIBLE PROBLEM	CORRECTIVE ACTION	TORQUE
Airlines	Air leaks	Replace airline	Compression Nut Hand Tight + 1 Turn
Fittings	Air leaks	Remove fitting and apply fresh joint compound. Reinstall fitting, but Do Not Overtighten. Do not use teflon tape.	Threaded into: Metal Plastic 15 Hand Tight Ft. Lbs. + 1 Turn
Air Springs	A. Improper height B. Air leakage	A. Adjust valve linkage to maintain proper air spring height. B. Replace air spring.	Size Metal Plastic 3/8 25 Ft. Lbs 04 Ft. Lbs 1/2 28 Ft. Lbs 10 Ft. Lbs 3/4 30 Ft. Lbs 10 Ft. Lbs
Height Control Valve	Air spring(s) will not inflate when wheight is added to the cab; OR Air spring(s) will not deflate when wheight is removed from the cab.	A. Inspect valve to insure drive bearing notch is located on "SUSP" port side of valve. If not, loosen lever screw (but do not remove completely) and pull lever loose from drive bearing, rotate drive bearing until the bearing notch is in the correct position and resecure lever by tightening lever screw. B. Replace Valve	1/4 Mount Fasteners 10 Ft. Lbs. Bearing Screw 40-50 InLbs.
Shock Absorber	Insufficient dampening effect	Replace shocks	45 Ft. Lbs.
Lateral Control Rod	A. Loose nuts on lateral control rod bolts B. Worn bushings.	A. Tighten securely to clamp the inner sleeve. B. Replace lateral control rod.	40 Ft. Lbs.

IMPORTANT: Periodically check the tightness of all fasteners.

PAGE INTENTIONALLY LEFT BLANK