

MODEL 6003 - 13.2K R-ARM SELF-STEER

14" - 17" Ride Height

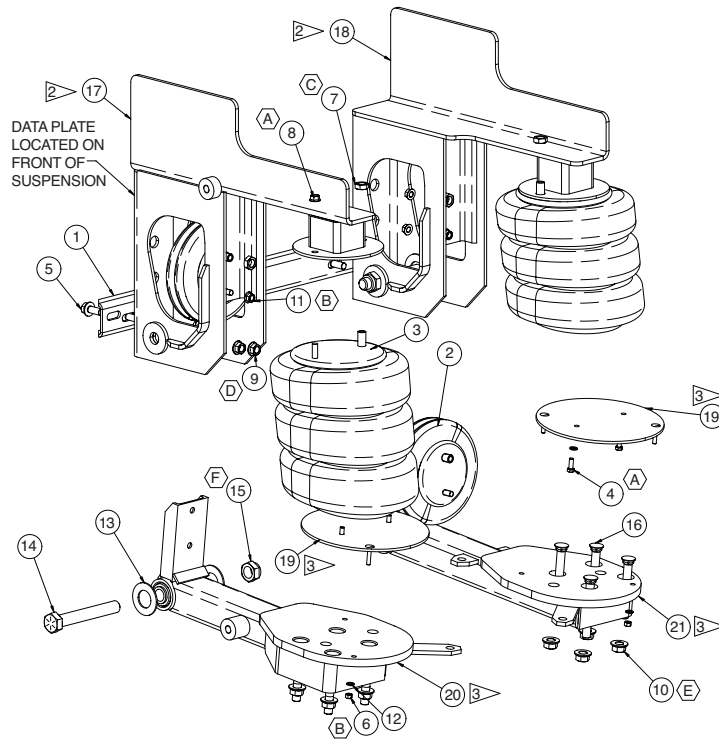

ITEM	PART NO	PART DESCRIPTION	QTY
1	8000025	CHANNEL-CROSSMEMBER.....	1
2	11030002	SPRING-AIR	2
3	11030003	SPRING-AIR	2
4	140B1208	3/8 X 1 UNC HEX CAP SCREW, OIL&PHOS (GR 8).....	4
5	141A2012	5/8 X 1 1/2 UNC FL BOLT, OIL&PHOS, (GR 8).....	4
6	14701200	3/8 UNC HEX NUT (GRADE B)	4
7	14752402	3/4 UNF HEX JAM NUT, OIL&PHOS	4
8	14801600	1/2 UNC HEX SERRATED FL NUT.....	6
9	14802004	5/8 UNC TOP LOCK FL NUT, OIL&PHOS	4
10	14802404	3/4 UNC TOP LOCK FL NUT, OIL&PHOS	8
11	14811600	1/2 UNF HEX SERRATED FL NUT	2
12	14851200	3/8 LOCK WASHER	8
13	14910002	THRUST WASHER	4
14	15060003	1 1/8 X 8 UNC HEX CAP SCR, (GRADE 8).....	2
15	15060005	1 1/8 UNC HEX TOP LOCK NUT, COLLAR STYLE.....	2
16	15060304	3/4 X 6.00 UNC PLOW HEAD BOLT	8
17	810A0024	BRACKET-6003 WELDMENT (LH FLUSH W/SB).....	1
18	810A0034	BRACKET-6003 WELDMENT (RH FLUSH W/SB)	1
19	820A0008	PLATE-AIR SPRING	2
20	820A1230	ARM-SUSPENSION (LRPBSSA).....	1
21	820A2238	ARM-SUSPENSION (RRXBSSA)	1
-	84001001	BUSHING.....	2

LINK PART NUMBERS:

8A000349
8A000613
8A000614

IMPORTANT NOTES:

- 1) WHEN REPLACING BUSHINGS, THE WEAR WASHER, BOLT AND NUT MUST BE REPLACED AS WELL

2) DATE/SERIAL NO. 00130001

PRIOR TO DATE	AFTER DATE	JULIAN DAY CODE YEAR
PART NO. 810A0730	PART NO. 810A0024 BRKT (LH)	
810A0830	810A0034 BRKT (RH)	

3) DATE/SERIAL NO. 00306001

PRIOR TO DATE	AFTER DATE	JULIAN DAY CODE YEAR
PART NO. 820A2218	PART NO. 820A2238 SUS ARM (RH)	
820A1210	820A1230 SUS ARM (LH)	

PART NO 820A0008 WAS NOT INCLUDED WITH THIS SUSPENSION PRIOR TO THE DATE CODE NOTED

- 4) WHEN ORDERING NEW SUSP ARMS (820A2238 OR 820A1230), PART NO 820A0008 MUST BE ORDERED AS WELL

- A) 15-20 FT-LBS
- B) 20-30 FT-LBS
- C) 40-50 FT-LBS
- D) 185-235 FT-LBS
- E) 325-420 FT-LBS
- F) 750-1000 FT-LBS

- 5) STEERING STABILIZER KIT 800A0020 MAY BE NEEDED.

