

# **link** **AIR LINK** **REDLINE**

FIRE & RESCUE TANDEM DRIVE AIR SUSPENSION

- + SPECIALTY ENGINEERED **SUSPENSION**
- + OPTIMIZE **CONTROL & STABILITY**
- + PROTECT **APPARATUS EQUIPMENT**
- + REDUCE **MAINTENANCE**



**MAXIMUM PERFORMANCE**  
WHEN LIVES ARE ON THE LINE

# LINK<sup>®</sup> AIR LINK<sup>®</sup> REDLINE

FIRE & RESCUE TANDEM DRIVE AIR SUSPENSION

## MAXIMUM PERFORMANCE WHEN LIVES ARE ON THE LINE

Fire departments and manufacturers challenged Link to create a suspension which optimizes fire apparatus vehicle performance and enhances maneuverability while demonstrating superior durability and reliability. Link answered the call with the Air Link<sup>®</sup> Redline performance series.

For over 20 years, Air Link<sup>®</sup> has been a proven product within fire and rescue applications. The suspension is tested and trusted by prestigious fire and military programs around the world to meet the demands of first response calls. Air Link<sup>®</sup> was first used in 1999 to help remedy ladder breakage for major fire truck OEMs. Today, the tandem drive suspension configuration is available with a weight rating of 48,000 to 65,000 pounds.



### OPTIMIZE CONTROL & STABILITY

The Air Link<sup>®</sup> suspension provides optimum stability in order to keep the driver safely in control of the fire apparatus. By reducing road vibration and impacts into the chassis the operator is able to both maintain their focus on the road and control during tight maneuvers and high-speed lane changes.

The suspension's design evenly distributes the load for maximum traction and maintained alignment. The enhanced stability delivers roll stiffness during cornering or maneuvering.

***"The customers have been extremely happy with the ride quality of their new aerials. I have no doubt that the Air Link<sup>®</sup> plays a large role in the smooth ride that our customers expect."***

***– Andy Herb*** *President of Herb Fire Equipment*



### PROTECT APPARATUS EQUIPMENT

Air link<sup>®</sup> is proven to isolate the chassis structure from excessive vibrations and impacts of the road. Large, high volume air springs offer optimal protection to critical life-saving equipment, costly aerial components and sensitive electronic equipment.

The high mounted air springs provide crucial clearance and excellent articulation for on- and off-highway response calls.

***"The Air Link<sup>®</sup> meets all our requirements for a suspension. We have realized significantly less long-term structural problems, and no jarring to the aerial equipment."***

***– Drew Sutphen*** *President of Sutphen Corporation*



### RELIABILITY AND EASE OF SERVICE

Air Link<sup>®</sup> is trusted by fire fighters around the world because of the unparalleled reliability, ease of service, and clear reduction in vehicle maintenance cost when compared to rubber block suspensions.

Engineered to the unique standards of the firefighter community, all Air Link<sup>®</sup> suspensions are equipped with composite air spring pistons, heavy duty bushings, and Link-KOAT<sup>®</sup> migratory self-healing metal treatment to provide maximum corrosion resistance and increase the vehicles service life.

***"The City of Syracuse, NY Department of Fire has used the Air Link<sup>®</sup> suspension for decades and has benefited from its reliability and ease of service. The department responds to 22,000 calls annually and operates this suspension on its tower fleet."***

***– Zach Smith*** *Fleet Maintenance Manager*

Specialty  
Engineered  
Suspensions

### 100% Off Highway Rating

- + Air Link® has the durability and reliability necessary for Fire Truck Applications

### Mounting System

- + Engineered weight bearing hangers provide stable and predictable handling
- + Available bolt pattern variations for C-Channel frame rails
- + Welded option for box frame design

### Air Springs

- + Large volume air springs offer low natural frequency for optimum ride quality
- + Proven to isolate the chassis structure from vibration stress and road impacts
- + Internal rubber jounce stops support the chassis structure with loss of air pressure

### Link Dual Height Control Valves

- + The 500 series valve has the highest flow rate in the industry to meet the performance needs of the fire apparatus
- + Dual height control valves balance the chassis and allow the suspension to react quickly to uneven load

### Shock Absorbers

- + Tuned and positioned for optimum ride characteristics
- + Controls downward and rebound movement
- + Designed to handle the weight of the suspension when lifted off the ground

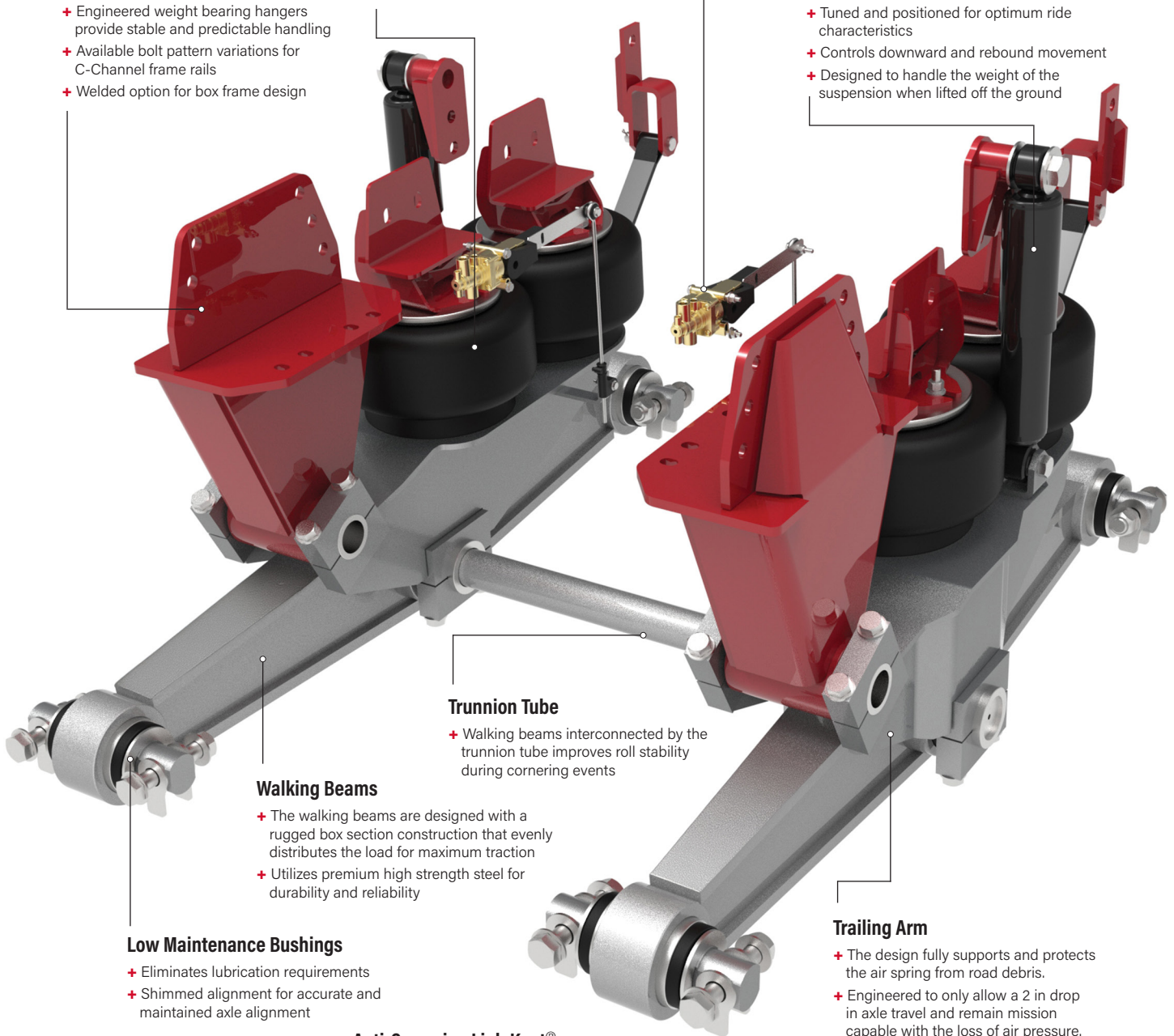

### Trunnion Tube

- + Walking beams interconnected by the trunnion tube improves roll stability during cornering events

### Walking Beams

- + The walking beams are designed with a rugged box section construction that evenly distributes the load for maximum traction
- + Utilizes premium high strength steel for durability and reliability

### Low Maintenance Bushings

- + Eliminates lubrication requirements
- + Shimmed alignment for accurate and maintained axle alignment

### Anti-Corrosion Link-Koat®

- + Self-healing metal treatment provides maximum corrosion resistance and rust protection

### Trailing Arm

- + The design fully supports and protects the air spring from road debris.
- + Engineered to only allow a 2 in drop in axle travel and remain mission capable with the loss of air pressure.

### Axle Availability

- + Fully integrates with main line axles such as Dana, Meritor and Mack

### Axle Control Rod Availability

- + Improve time between maintenance intervals with available Link® control rods

### Retrofit Availability

- + Product option codes and bolt on retrofit kits are available



Link develops and manufactures a variety of suspensions, suspension controls, and specialty products, engineered to address the unique needs of specialty vehicle markets. Link is tier-1 supplier whose primary products include cab, auxiliary and chassis suspensions, including heavy vocational, off-highway and air suspension management technologies.

Link manufacturing is IATF 16949 and ISO 14001: 2015 (EMS) certified with company locations in the United States and Canada.

**AIR LINK® REDLINE PARTNERS**



**AIR LINK® REDLINE SPECIFICATION**

Product No.	Capacity	Weight (base unit)	Axle Spread (Min)	Axle Spread (Max)
<b>AL-520-TD</b>	<b>52,000</b> LBS	<b>1,250</b> LBS	<b>52</b> IN	<b>54</b> IN
<b>AL-540-TD</b>	<b>54,000</b> LBS	<b>1,350</b> LBS	<b>54</b> IN	<b>54</b> IN
<b>AL-600-TD</b>	<b>60,000</b> LBS	<b>1,400</b> LBS	<b>52</b> IN	<b>60</b> IN
<b>AL-650-TD</b>	<b>65,000</b> LBS	<b>1,425</b> LBS	<b>60</b> IN	<b>60</b> IN

**CONTACT LINK MANUFACTURING, LTD.**

800-222-6283 | [info@linkmfg.com](mailto:info@linkmfg.com)

[www.linkmfg.com](http://www.linkmfg.com)