

**Suspension  
Controls**

**LINK<sup>®</sup>**

# INSTALLATION INSTRUCTIONS

**500 Series  
Height Control Valve**  
Dual Ports  
(H00500)



Link Mfg. Ltd.  
223 15th St. N.E.  
Sioux Center, IA USA  
51250-2120  
[www.linkmfg.com](http://www.linkmfg.com)

**QUESTIONS?  
CALL CUSTOMER  
SERVICE  
1-800-222-6283**

**IMPORTANT:** IT IS IMPORTANT THAT THE ENTIRE INSTALLATION INSTRUCTIONS BE READ THOROUGHLY BEFORE PROCEEDING WITH THE INSTALLATION.





## 1. INTRODUCTION

Thank you for choosing a Link Suspension Control. We want to help you get the best results from this height control valve and to operate it safely. This instruction contains information to assist in the installation of the Height Control Valve. This instruction is intended solely for use with this product.

All information in this instruction is based on the latest information available at the time of printing. Link Manufacturing reserves the right to change its products or manuals at any time without notice.

Damaged components should be returned to Link with a pre-arranged Returned Materials Authorization (RMA) number through the Customer Service Department. The damaged component may then be replaced if in compliance with warranty conditions.

## 2. SAFETY SYMBOLS, TORQUE SYMBOL, and NOTES

	<b>DANGER</b> indicates a hazardous situation which if not avoided, will result in death or serious injury.
	<b>WARNING</b> indicates a potentially hazardous situation which, if not avoided, could result in death or serious injury.
	<b>CAUTION</b> indicates a potentially hazardous situation which, if not avoided, could result in minor or moderate injury.
	<b>NOTICE</b> indicates a potentially hazardous situation which, if not avoided, may result in property damage.
	<b>TORQUE</b> indicates named fasteners are to be tightened to a specified torque value.
<b>NOTE:</b>	A Note provides information or suggestions that help you correctly perform a task.

## 3. SAFE WORKING PRACTICES

### CAUTION

When handling parts, wear appropriate gloves, eye-glasses, ear protection, and other safety equipment.

### CAUTION

Proper tightening of fasteners is important to the performance and safety of the suspension. Follow all torque specifications throughout the instructions.

## 4. SAFE WORKING PRACTICES

### CAUTION

#### 4.1

Air lines are pressurized and may blow debris, USE EYE PROTECTION.

## 5. HCV INSTALLATION

#### 5.1

Disconnect and remove old valve.

#### 5.2

Attach the Link H00500 HCV to the same mounting bracket. Or use the enclosed brackets as needed to mount the valve.

1. Always mount valve with lever arm on the top side.
2. At full up or down suspension travel:  
MAXIMUM LEVER ANGLE IS 45°  
MINIMUM LEVER ANGLE IS 30°
3. Mount HCV parallel to frame rail
4. If NOT using the integral dump option, vent dump port with 3-inch (minimum) length of hose.
5. If using integral dump option, remove dump pilot port vent and connect directly to 3-way selector valve. Ensure that selector system is vented to atmosphere at all times (even when not being activated).

**NOTE:** Dump pilot port/system must not be plugged at any time as this may affect valve centering.

#### 5.3

Attach the proper length lever to achieve 30° minimum fill and exhaust angle (see above notes). Check for any interference or straight lining of the valve lever and link-ages through the entire suspension travel.

#### 5.4

Reconnect the air lines to the H00500 HCV per figure 1 on page 3. Connect the dump pilot port to a normally closed control valve.

#### 5.5

Adjust the ride height of the suspension utilizing the H00500 HCV lever and the vehicle manufacturer's ride height recommendations. Install centering dowel to ensure the valve dead band is at ride height.

Figure 1.

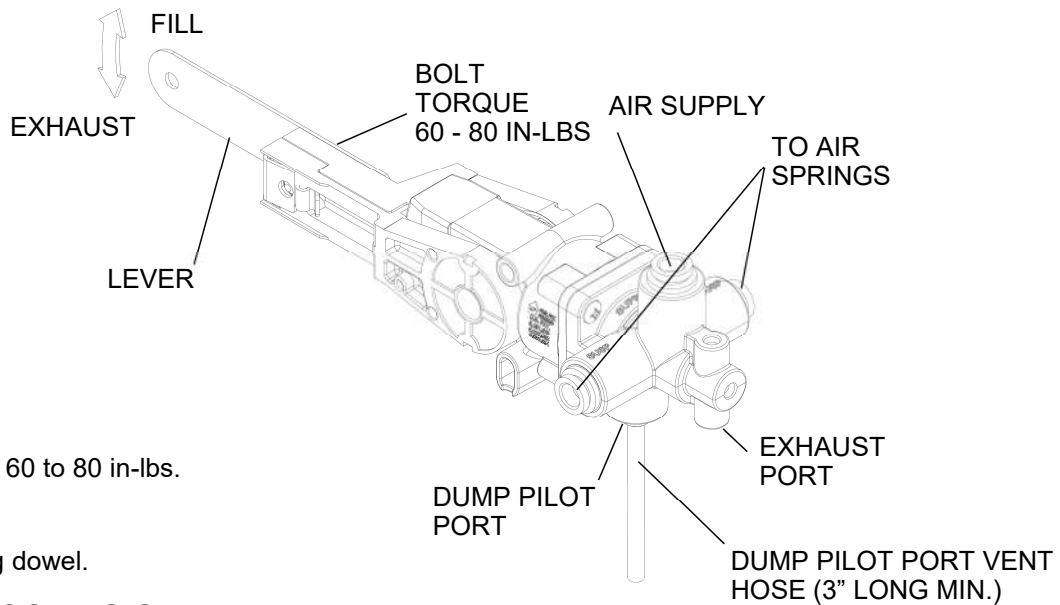

**5.6**

Tighten all nuts to 60 to 80 in-lbs.

**5.7**

Remove centering dowel.

**6. TROUBLE SHOOTING GUIDE**

PROBLEM	POSSIBLE CAUSE
Air springs flat	Obstruction in air line Insufficient air pressure to suspension Defective Pressure Protection Valve Defective HCV-see test procedure Air leak in system
Air Springs raise to full height but do not exhaust	Obstructed air line Defective HCV-see test procedure
Air springs deflate when parked	Leak in air system-check with soapy water Defective HCV-see test procedure
Suspension will not maintain proper height	Check dump port for proper venting Obstructed air line Defective HCV-see test procedure
Hard ride	Ride height out of adjustment-readjust per vehicle service manual
Ride height unequal side to side for (2) valve system	Check dump port for proper venting Reset ride height on each side

**7. HCV TEST PROCEDURE**

**7.1**

With a minimum of 90 psi at the supply port, rotate the lever up (as indicated on the side of the valve) 30° to 45°. Air should begin to flow into the air springs within seconds.

**7.2**

Rotate the lever to the neutral position. Air flow should stop.

**7.3**

Rotate the lever down 30° to 45°. Air should begin to exhaust from the air springs within seconds.

**7.4**

Rotate the lever to the neutral position. Air flow should stop.

**7.5**

If the valve fails to flow air or shut off as specified, replace with a new one.

**8. REASONS TO REPLACE THE HCV**

**8.1**

- HCV did not pass the test procedure
- Air leaks from the HCV
- HCV is damaged

Figure 2.

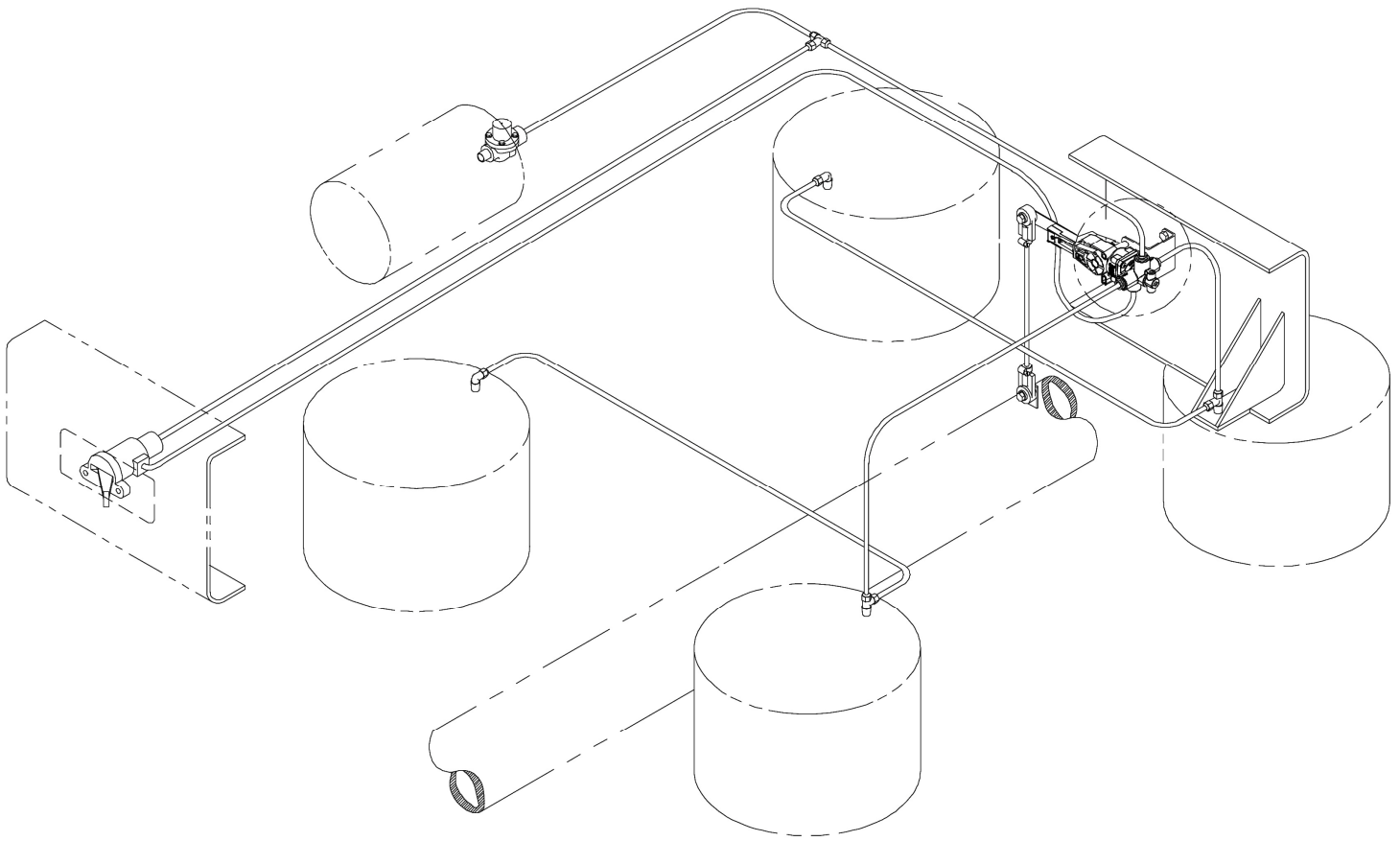

LINK MANUFACTURING, LTD.  
223 15TH ST. NE, SIOUX CENTER, IA 51250  
1-800-222-6283 [www.linkmfg.com](http://www.linkmfg.com)