

DURALIFT II 20K SELF-STEER

Link Part Number: 8A000728 - Current

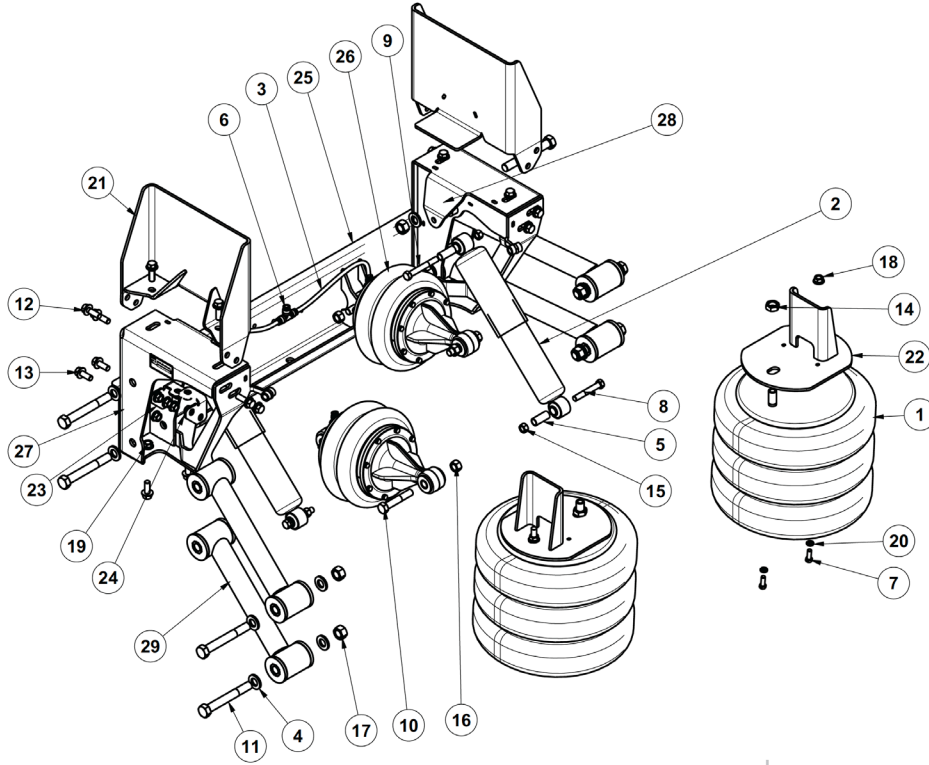

**REPLACEMENT
KIT PART
NUMBERS:**

ARM BUSHING KIT:
800A0133

IMPORTANT NOTES:
1. MULTIPLE OPTIONS
EXIST—CALL FOR
DETAILS.

ITEM	PART NO	PART DESCRIPTION	QTY
1	11030001	SPRING-AIR.....	2
2	12100011	ENTER DESCRIPTION HERE	2
3	13034000	AIRLINE-NYLON, 3/8" BULK (FEET)	1.9
4	14882402	3/4 HARDENED WASHER, ZINC PLATED.....	16
5	80000009	BUSHING-SHOCK, ACETAL.....	4
6	1302-5061	TEE-UNION, 3/8 TUBE	1
7	140B-1208	3/8 X 1 UNC HEX CAP SCR (GR 8) O&P.....	4
8	140D-1626	1/2 X 3 1/4 UNF HEX CAP SCR (GR 8) O&P	2
9	140D-1630	1/2 X 3 3/4 UNF HEX CAP SCR (GR 8) O&P	2
10	140D-2028	5/8 X 3 1/2 UNF HEX CAP SCR (GR 8) O&P	4
11	140D-2446	3/4 X 5 3/4 UNF HEX CAP SCR (GR 8) O&P	8
12	141A1612	1/2 X 1 1/2 UNC FLANGE BOLT (GR 8) O&P.....	12
13	141A-1610	1/2 X 1 1/4 UNC FLANGE BOLT (GR 8) O&P	8
14	1475-2402	3/4 UNF HEX JAM NUT, O&P	2
15	1477-1606	1/2 UNF HEX TOP LOCK NUT (GR C) O&P.....	4
16	1477-2006	5/8 UNF HEX TOP LOCK NUT (GR C) O&P.....	4
17	1477-2406	3/4 UNF HEX TOP LOCK NUT (GR C) O&P.....	8
18	1480-1600	1/2 UNC SERRATED FLANGE NUT.....	2
19	1480-1604	1/2 UNC TOP LOCK FL NUT (GR G) O&P.....	8
20	1485-1200	3/8 LOCK WASHER.....	4
21	SEE NOTE 1	BRACKET-MOUNT, FRAME.....	2
22	SEE NOTE 1	BRACKET-MOUNT, AIRSPRING.....	2
23	800A0250	BRACKET-MOUNT, FASTENER	2
24	800A0251	BRACKET-MOUNT, FASTENER	2
25	800A0257	WELDMENT-CROSSMEMBER	1
26	800A0309	ACTUATOR-SPRING, LIFT	2
27	810A0058	BRACKET-HANGER, SUSPENSION.....	1
28	810A0059	BRACKET-HANGER, SUSPENSION.....	1
29	820A0034	ARM-CONNECTING	4



