

DURALIFT II 8K SELF-STEER

Link Part Number: 8A000716 - Non-Current

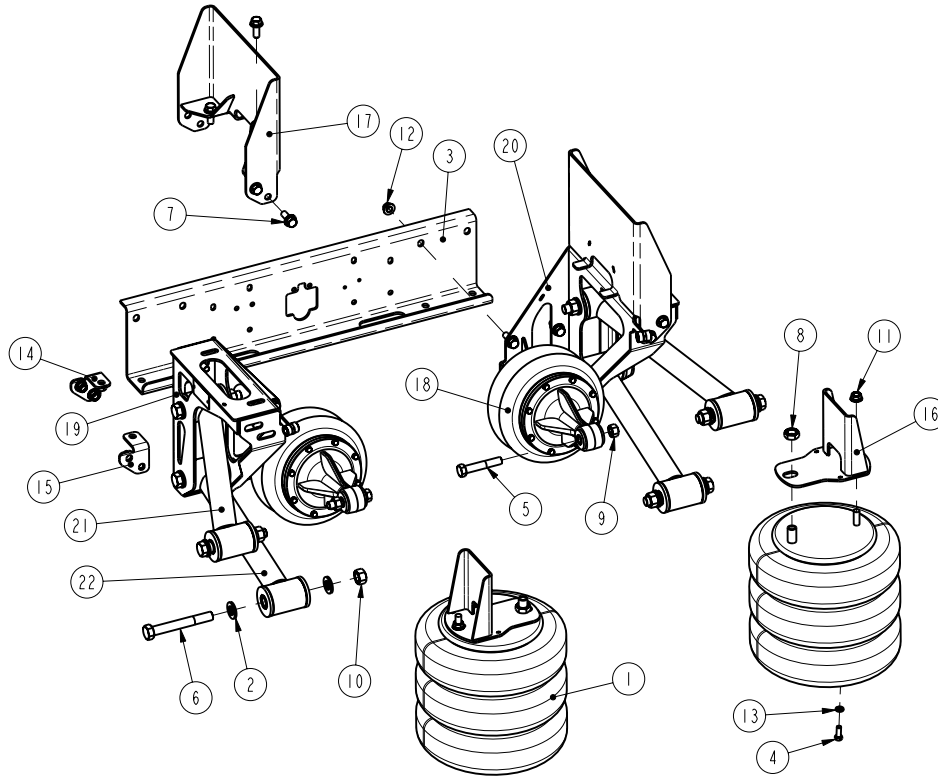

**REPLACEMENT
KIT PART
NUMBERS:**

ARM BUSHING KIT:
800A0133

IMPORTANT NOTES:

1. MULTIPLE OPTIONS
EXIST—CALL FOR
DETAILS.

ITEM	PART NO	PART DESCRIPTION	QTY
1	11030056	SPRING-AIR	2
2	14882402	3/4 HARDENED WASHER, ZINC PLATED.....	16
3	80002109	CROSSMEMBER-DURALIFT2.....	1
4	140B1208	3/8 X 1 UNC HEX CAP SCR (GR 8) O&P.....	4
5	140D2028	5/8 X 3 1/2 UNF HEX CAP SCR (GR 8) O&P.....	4
6	140D2446	3/4 X 5 3/4 UNF HEX CAP SCR (GR 8) O&P.....	8
7	141A1610	1/2 X 1 1/4 UNC FLANGE BOLT (GR 8) O&P.....	20
8	14752402	3/4 UNF HEX JAM NUT, O&P.....	2
9	14772006	5/8 UNF HEX TOP LOCK NUT (GR C) O&P.....	4
10	14772406	3/4 UNF HEX TOP LOCK NUT (GR C) O&P.....	8
11	14801600	1/2 UNC SERRATED FLANGE NUT.....	2
12	14801604	1/2 UNC TOP LOCK FL NUT (GR G) O&P.....	8
13	14851200	3/8 LOCK WASHER.....	4
14	800A0120	BRACKET-MOUNT, FASTENER.....	2
15	800A0121	BRACKET-MOUNT, FASTENER.....	2
16	SEE NOTE 1	BRACKET-MOUNT, AIRSPRING.....	2
17	SEE NOTE 1	BRACKET-MOUNT, FRAME.....	2
18	800A0309	ACTUATOR-SPRING, LIFT.....	2
19	810A0096	BRACKET-HANGER, SUSPENSION.....	1
20	810A0097	BRACKET-HANGER, SUSPENSION.....	1
21	820A0033	ARM-CONNECTING.....	2
22	820A0084	ARM-CONNECTING.....	2



DURALIFT II 8K SELF-STEER

Link Part Number: 830A0308 - Non-Current

Axle Assembly for 8A000716 Suspension

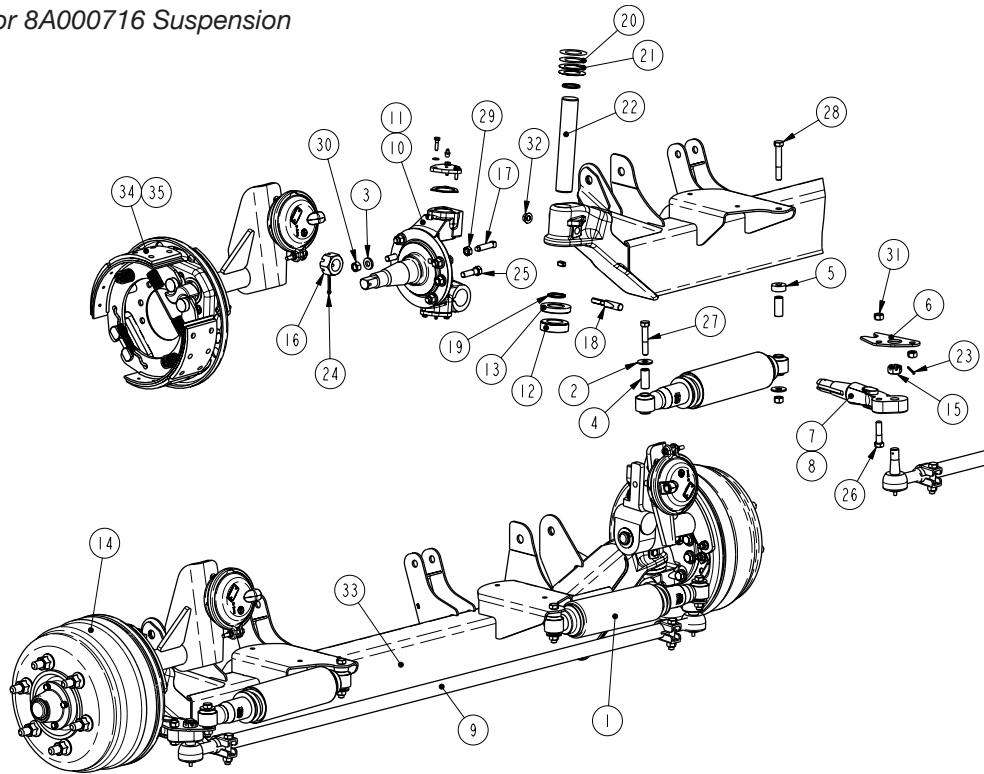

**REPLACEMENT
KIT PART
NUMBERS:**

KING PIN KIT:
84001933

SHOCK KIT:
12100015

ITEM	PART NO	PART DESCRIPTION	QTY
1	12100012	SHOCK ABSORBER, WIDE BODY	2
2	14871600	1/2 TYPE A PLAIN WASHER	4
3	14881602	1/2 HARDENED WASHER, ZINC PLATED.....	24
4	80000009	BUSHING-SHOCK, ACETAL.....	4
5	83000079	SPACER-MOUNT, SHOCK	2
6	83000096	PLATE-MOUNT, SHOCK.....	2
7	83000097	ARM-STEERING, 8K	1
8	83000098	ARM-STEERING, 8K.....	1
9	84001034	TIE ROD ASSEMBLY.....	1
10	84001233	ASSEMBLY-KNUCKLE, 8K (LEFT).....	1
11	84001234	ASSEMBLY-KNUCKLE, 8K (RIGHT)	1
12	84001433	BEARING-THRUST	2
13	84001434	CAP-BEARING	2
14	84001508	HUB & DRUM-FN, 12.8X4	2
15	84001697	NUT-HEX, SLOTTED, .75	2
16	84001698	NUT-HEX, SLOTTED, 1.13	2
17	84001699	BOLT-STOP, STEERING.....	2
18	84001928	PIN-DRAW, LOCKING.....	2
19	84001987	SEAL-KNUCKLE	4
20	84001988	SHIM (.005).....	4
21	84001989	SHIM (.010).....	4
22	84001990	PIN-KING, 8K	2
23	84001995	PIN-COTTER, .13 X 1.75.....	2
24	84001996	PIN-COTTER, .18 X 2.00.....	2
25	14021614	1/2 X 1 3/4 UNF HEX CAP SCR (GR 8).....	12
26	140D1616	1/2 X 2 UNF HEX CAP SCR (GR 8) O&P	2
27	140D1622	1/2 X 2 3/4 UNF HEX CAP SCR (GR 8) O&P	2
28	140D1626	1/2 X 3 1/4 UNF HEX CAP SCR (GR 8) O&P	2
29	14741600	1/2 UNC HEX JAM NUT.....	2
30	14761601	1/2 UNC HEX TOP LOCK NUT (GR C).....	12
31	14771606	1/2 UNF HEX TOP LOCK NUT (GR C) O&P	6
32	14801404	7/16 UNC TOP LOCK FL NUT (GR G) O&P.....	2
33	830A0307	AXLE-FAB., 8K DURALIFT2.....	1
34	84001612	BRAKE ASSY-L	1
35	84001613	BRAKE ASSY-R.....	1

