

Dodge Ram 4500/5500 4x2 & 4x4

(8M000100)

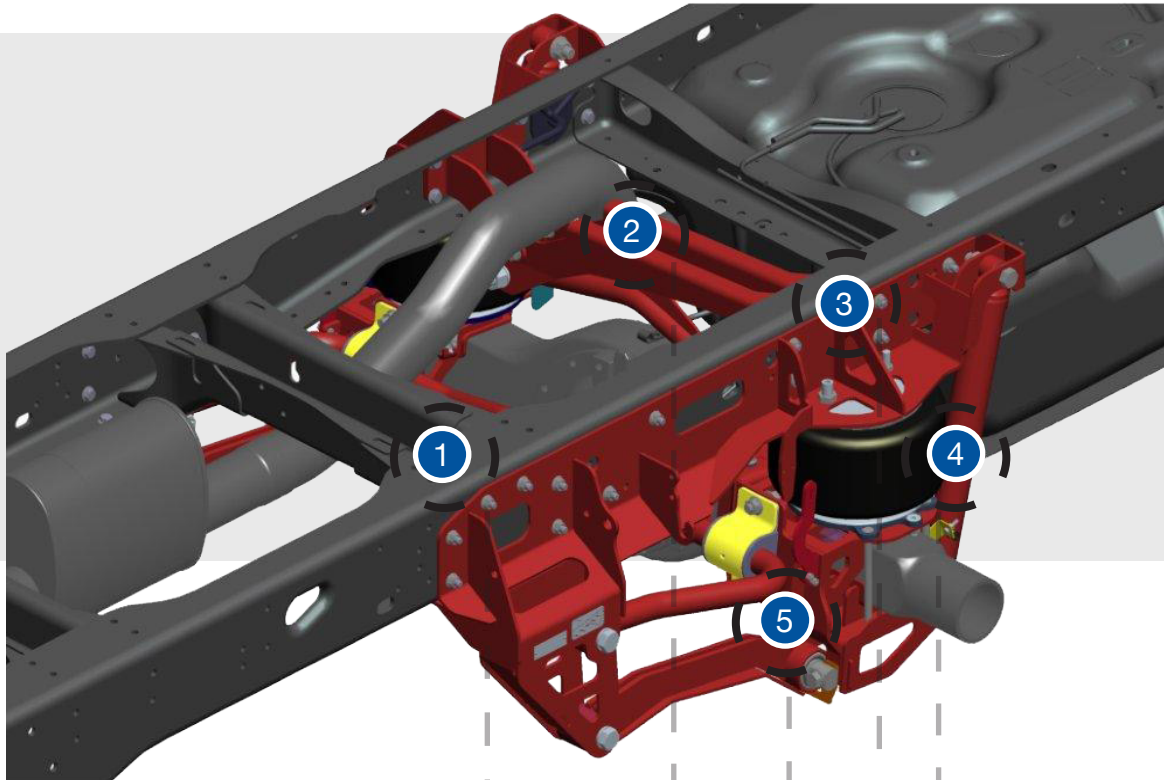

- 1 Existing Frame Holes
- 2 Additional Crossmember
- 3 Frame Mount & Air Spring Bracket
- 4 Rear Outboard Shocks
- 5 LCR Shims & Lower Control Arm Shims

SUSPENSION INCLUDES

- Basic Unit
- Integrated 1 3/4" Stabilizer Bar
- Custom Tuned UltraRide Shocks
- Axle Kit

FEATURE	BENEFIT
Existing Frame Holes	Reduces Install Time
Additional Crossmember	Reduces Frame Stress
One Piece Frame Mount & Air Spring Bracket	Reduces Stress for a Long Service Lift
Rear Outboard Shocks	Increases Stability
Lateral Control Rod Shims & Lower Control Arm Shims	For Proper Axle Alignment

SUSPENSION SPECIFICATIONS

MODEL	Dodge Ram 4500/5500
YEAR	2008 - Newer
RIDE HEIGHT	17.80"
AIR SPRING DESIGN HEIGHT	7.50"
AXLE TRAVEL	2.9" Jounce (B/C) 4.0" Jounce (M/M) 2.9" Rebound (M/M)
LINK PART NUMBER	8M000100
STYLE	Parallelogram
WEIGHT	450 LBS
CAPACITY	12,000 LBS & 13,500 LBS

TOP VIEW

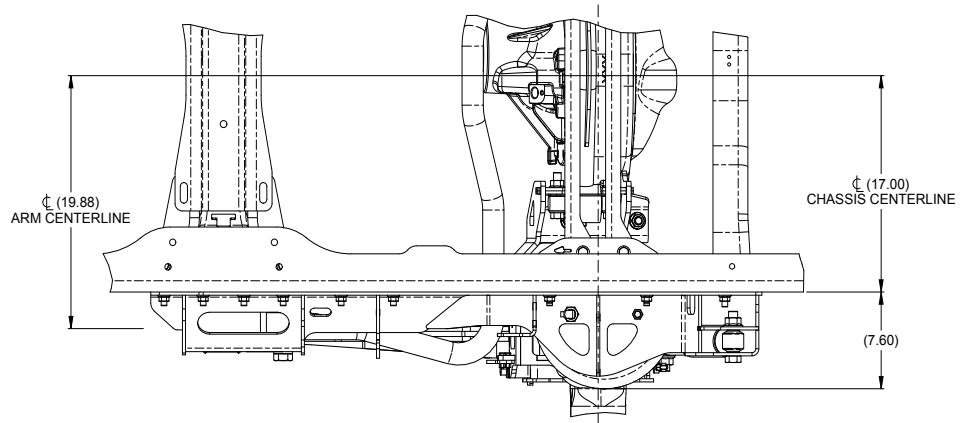

SIDE VIEW

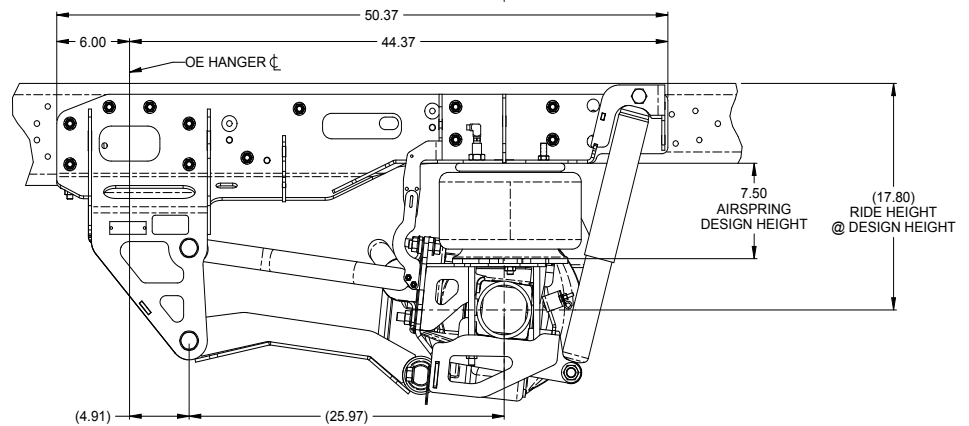

INSTALLATION NOTES

Need to remove jounce bumper from underside of frame.

Need to remove spring pad from top of axle

Drilling required at Air Spring/Shock location.