

Ford F350

Super Duty 4/4 Chassis Cabs with Ambulance Package

(8M000068)

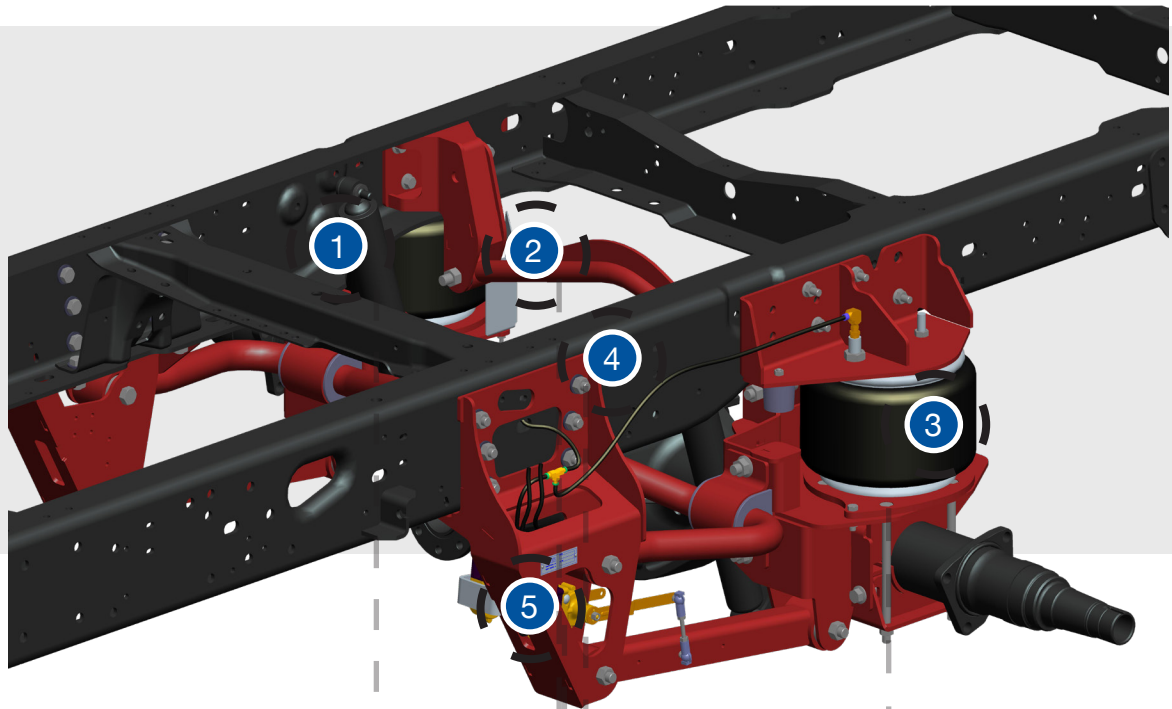

- 1 Tuned Shock Absorbers
- 2 Lateral Control Device
- 3 Rate Tailored Air Springs
- 4 Existing Frame Holes
- 5 Heavy Duty Height Control System

FEATURE	BENEFIT
Tuned Shock Absorbers	Maximize Comfort & Stability
Lateral Control Device	Assures Alignment & Tracking
Rate Tailored Air Springs	Include Internal Stop for Best Ride
Existing Frame Holes	Reduces Install Time
Heavy Duty Height Control System	Maintains Optional Ride Height Loaded or Unloaded

SUSPENSION SPECIFICATIONS

MODEL	Ford F350 Chassis Cab Ambulance Prep Package
YEAR	2005 - 2007
RIDE HEIGHT	17.06"
AIR SPRING DESIGN HEIGHT	7.40"
AXLE TRAVEL	2.50" Jounce (B/C) 3.00" Jounce (M/M) 2.70" Rebound (M/M)
LINK PART NUMBER	8M000068
STYLE	Parallelogram
WEIGHT	TBD
CAPACITY	9,750 LBS

TOP VIEW

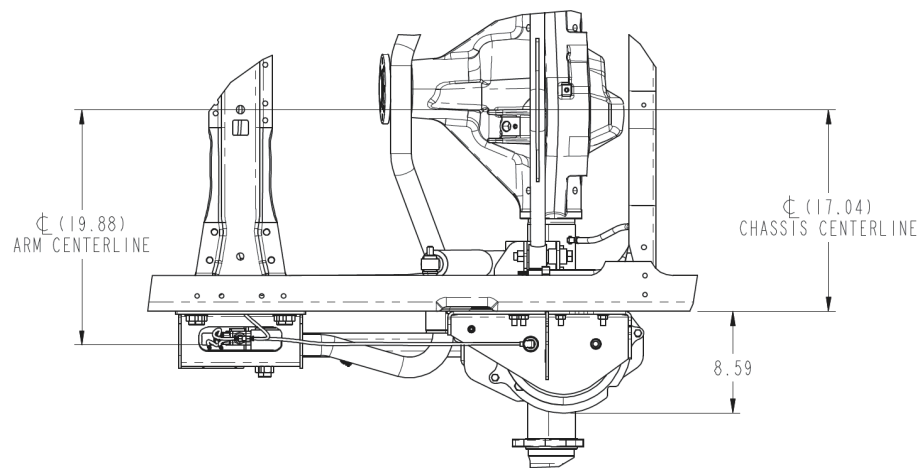

SIDE VIEW

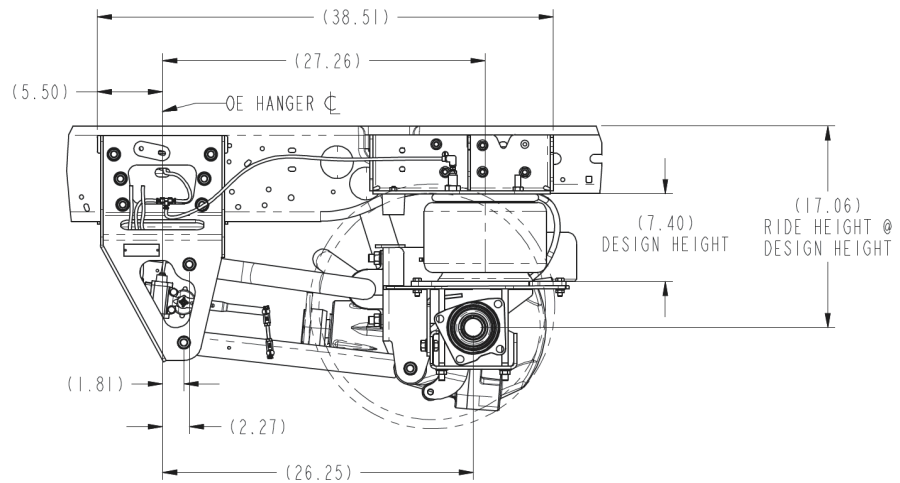

INSTALLATION NOTES

Exhaust hanger may need to be modified slightly in case the exhaust is closer than 1" away from the suspension exhaust shield.

Air spring frame mounts will require the drilling of 3 holes and reaming of 2 holes.