

LINK[®] UltraRide[®]

Chassis Air Suspension
ELECTRONIC AIR
CONTROL KIT

Questions ? Contact this Professional Installer :

Model # 800M1400

Company : _____

Lot/Serial#

Phone : _____

Installer : _____ Date : _____

Please Read this manual before operating your UltraRide[®] Suspension, and keep it for future reference.

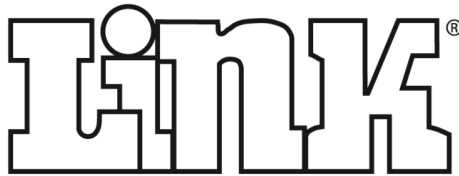

Link Mfg. Ltd.
223 15th St. NE
Sioux Center, IA USA
51250-2120

For questions with your UltraRide[®] suspension system, please call Toll Free
1.800.222.6283

Internet Address: <http://www.linkmfg.com/>

YOUR TRUST... OUR PASSION!

Contents

1. INTRODUCTION	2
2. LINK® LIMITED WARRANTY	4
3. AIR SYSTEM OPERATION	5
4. SERVICE & MAINTENANCE	6
5. TROUBLESHOOTING	7
6. FUSES.....	8
ELECTRONIC AIR CONTROL KIT	9
PARTS LIST.....	9
OPTIONAL CONTROL PANEL PARTS LIST	10
CHASSIS INTEGRATION WIRING HARNESS ELECTRICAL SCHEMATIC.....	11
INTERNAL WIRING HARNESS ELECTRICAL SCHEMATIC.....	12
PNEUMATIC SCHEMATIC	13
AIR KIT CONTROL PANEL ELECTRICAL SCHEMATIC	14

1. INTRODUCTION

Thank you for choosing the Link® **UltraRide**® Electronic Air Control Kit for your vehicle. With no lubrication required and only periodic maintenance as indicated in this manual, your **UltraRide**® system will provide many miles of reliable, trouble free service.

In the unlikely event of a suspension malfunction between regular vehicle maintenance intervals, immediate corrective action should be taken to prevent further suspension damage. Our website, www.linkmfg.com/ultraride/urdealers.html, can locate a Link dealer near you.

The **UltraRide**® Electronic Air Control Kit is intended ONLY to provide a pressurized air supply for Link **UltraRide**® Chassis Suspensions and control the lift and dump action of the suspension.

Any other use of these Air Control Products is not authorized. Link Mfg., Ltd. Accepts no warranty responsibility for damage resulting from misuse.



The **UltraRide**® Electronic Air Control Kit provides a convenient and dependable control system for your **UltraRide**® suspension system. The Electronic Air Control Kit both provides a source of compressed air for the suspension as well as controls the height of the suspension.

OWNER RESPONSIBILITIES

The **UltraRide**® Electronic Air Control Kits need no lubrication and requires only a little maintenance. However, immediate corrective action should be taken if a serious malfunction occurs.

- Owner is solely responsible for pre-operation inspection, periodic inspections, maintenance, and use of the product as specified in the particular Link Mfg., Ltd. Instructions available by product model, except as provided in warranty, and for maintenance of other vehicle components.
- Owner is responsible for all “down time” expenses, cargo damage, and all business costs and losses resulting from a warrantable failure.

SAFETY SYMBOLS, TORQUE SYMBOL, and NOTES

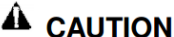
	<p>This is the safety alert symbol. It is used to alert you to potential personal injury hazards. Obey all safety messages that follow this symbol to avoid possible injury or death.</p>
	<p>WARNING indicates a potentially hazardous situation which, if not avoided, could result in death or serious injury.</p>
	<p>CAUTION indicates a potentially hazardous situation which, if not avoided, could result in minor or moderate injury.</p>

<p>CAUTION</p>	<p>CAUTION used without the safety alert symbol indicates a potentially hazardous situation which, if not avoided, may result in property damage.</p>
<p>NOTE:</p>	<p>A Note provides information or suggestions that help you correctly perform a task.</p>
	<p>The electrical symbol indicates the presence of electric shock hazards which, if not avoided, may result in injury to personnel or damage to equipment.</p>

2. LINK® LIMITED WARRANTY

ULTRARIDE® ELECTRONIC AIR KIT 800M1400

What Is Covered

This warranty covers any defects in materials or manufacture. This warranty does not cover ordinary wear and tear, routine maintenance, or damage caused by alteration or improper installation, use, or maintenance of the Product.

How Long Coverage Lasts

For all components including the air compressor, this warranty runs for 3 years from the date the Product was sold to its original end-user (the "Sale Date") or 60,000 miles, whichever occurs first.

What Link Will Do

Link will repair or replace any Product that does not conform to this warranty. Link will also reimburse for installation of repaired or replacement parts as follows:

Labor Description	Hours	Hourly Rate
Relay	0.75	\$90.00
ECU	1	\$90.00
Compressor	1	\$90.00
Manifold	1.3	\$90.00
Inclination Sensor	0.5	\$90.00
Rotary Sensor X1	0.5	\$90.00
Harness	1.5	\$90.00
Internal Fuse	0.6	\$90.00

How To Get Warranty Service

Telephone Link Customer Service at 1-800-222-6283. You may also take the Product to any authorized Link distributor or dealer. You will be responsible for removing the Product from the vehicle and shipping it to Link at your expense. You must submit documentation of the date and vehicle mileage when the Product was sold to its original end-user and the vehicle's current mileage.

Limitations & Exclusions

Link will not be responsible for incidental or consequential damages, including loss of use or profits.

LINK DISCLAIMS ANY WARRANTY OF MERCHANTABILITY OR FITNESS FOR A PARTICULAR PURPOSE.

This warranty does not apply if the Product is used with accessories not approved by Link or when other than Link Genuine Replacement Parts have been installed on the Product.

Link does not warrant accessories supplied by Link that bear the name of another company.

Link reserves the right to provide refurbished parts in response to a warranty claim.

Parts supplied in response to a warranty claim are warranted only for the remainder of the original warranty period.

3/3/2015

3. AIR SYSTEM OPERATION

The **UltraRide®** Electronic Air Control Kit keeps the suspension at a consistent level by monitoring Height sensors that feed position information to the ECU (electronic control unit) which controls a set of valves to either add or remove air from the air springs.

The **UltraRide®** Electronic Air Control Kit is programmed to dump the air in the suspension to a specific height, to improve ingress & egress accessibility for various vehicles. By dumping to a height, air is conserved, improving compressor lift recovery time. This Dump Height can be adjusted. See your local Link Mfg. Service Representative for details.

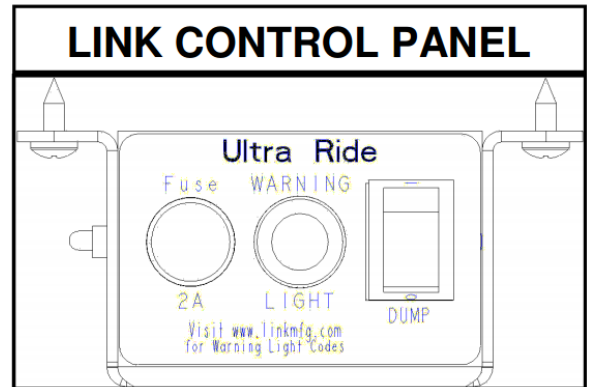

Warning Light

The **UltraRide®** Control panel includes a warning light showing the system status.

Normal Operation Mode (Warning Light Remains off)

- During normal driving operation, the system maintains suspension Ride Height and does not require any user input.
- Tank Pressure is maintained between 120 & 155 psi.

Dump Mode (Warning Light is ON)

- To dump or lower the suspension, activate the dump switch (note: depending on the application, there may be multiple ways to activate the dump mode, e.g. opening the rear doors of an ambulance)
- The electronic air control kit will dump the suspension to a pre-programmed height and hold it there, maintaining some air pressure in the air springs.



CAUTION!!!! The **vehicle should NOT be driven** while the suspension is dumped. Doing so can result in damage to the suspension and/or the vehicle.

- Tank Pressure is maintained between 120 and 155 psi so it is 'topped off' and ready for dump recovery.

Deactivating (Exiting) Dump Mode

- To exit Dump Mode and return to normal operation with the suspension at Ride Height, first disable all dump switch(es). Then, activate the recovery trigger (defined by installer).
- NOTE: The suspension will NOT return to normal Ride Height until the recovery trigger activated

Setting Suspension Ride Height

- The suspension Ride Height is set by the installer, but should be checked and maintained periodically.
- Power up the electronic air control kit and allow the air tank to reach full pressure (the compressor is off).
- Measure ride height as specified in your **UltraRide®** suspension manual. Adjustments may be made by changing the length of the height sensor lever or by using the Link Diagnostic Interface, as detailed in the installation manual available at www.linkmfg.com.

4. SERVICE & MAINTENANCE

The **UltraRide**® Electronic Air Control Kit needs no lubrication and little maintenance. The following components should be checked at the time the truck is being serviced. However, immediate corrective action should be taken if a serious malfunction occurs.



CAUTION! If maintenance or service is to be done on the air system, be sure to drain **all** air from system. Serious injury could occur if components are removed while system is full of air.

It is important to release any moisture contained within the air reservoir weekly!

Even with the advanced features of the electronic air kit system along with accessories like air dryers, moisture can build up in the air tank and should be checked.

This can be done by pulling on the cable attached to the drain valve. Not releasing the moisture on a regular basis will cause the drain valve to operate improperly, and may cause the air kit to malfunction. Excess moisture in the system can also cause premature failure of other components including the tank itself.

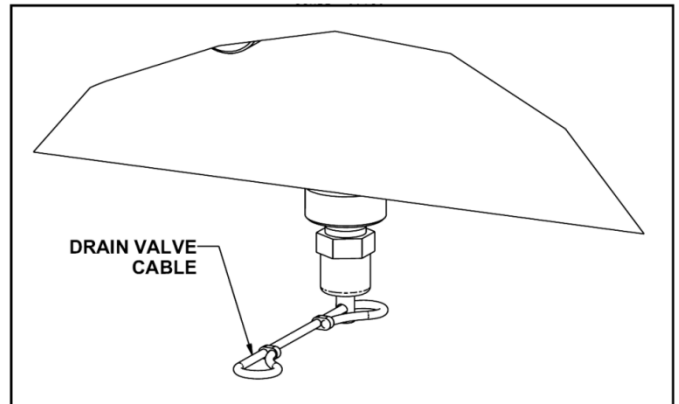

Operational Notes:

- The Warning Light
 - Solid on: Suspension is Dumped and vehicle should not be driven.
 - Blinking: There is an error and the vehicle should not be driven.
- A minimum tank pressure 90 psig is required for the system to recover from a suspension dump. The Air Control Kit will not dump if there is not sufficient pressure to recover.

EVERY Week

- Manually drain excess moisture from tank.

EVERY 3,000 miles or every oil change:

- Check for air leaks around fittings.
- Check air filter; replace if necessary.

EVERY 30,000 miles or 6 months, whichever comes first:

- Replace the air filter.

5. TROUBLESHOOTING

Problem / Symptom	Possible Causes	CORRECTIVE ACTIONS
Air Tank Leaks down*	A. Fittings on air tank leaking B. Damaged Airline to tank C. Faulty Valve manifold	A. Tighten or replace fittings B. Replace Damaged Airline C. Replace valve manifold
Air Spring(s) Leaks down*	A. Fittings on Air Spring Leaking B. Damaged Air Spring C. Damaged airline to air spring D. Faulty Valve manifold	A. Tighten or replace fittings B. Replace air spring C. Replace damaged airline D. Replace valve manifold
Compressor does not run	A. Ignition Key is not on B. Fuse(s) blown C. Tank is full	A. Turn on the ignition key to power the system B. Check and replace fuses. C. Nothing wrong, normal operation
Compressor runs too much	A. Leak in system B. Plugged Air Filter C. Faulty Compressor	A. Find and stop leak B. Replace Air Filter C. Replace Compressor
Suspension does not dump	A. Ignition Key is not on B. Improper height settings C. Loose connections D. Air Tank Pressure is Low	A. Turn on the ignition key to power the system B. See manual to program the height settings C. Check all electrical connections. D. Allow time for compressor to fill tank.
Suspension does not recover after dump	A. Brake pedal not pressed B. Brake input not properly connected	A. Press the vehicle brake pedal B. Check installation & wiring of brake input wire
Warning Light is on	A. Suspension is dumped	A. Nothing wrong, normal operation.
Warning light is blinking	A. Error or System Malfunction	A. Use the Link Air Tools Diagnostic Software to diagnose cause of error.

* NOTE: All air systems will always have some inherent leaks and will, over a long period of time, leak down.

6. FUSES

2A Fuse in Control Panel

- If your vehicle is equipped with the Link 800M1074 control panel, there is a 2A fuse located in that control panel between the ignition power and the rest of the air kit electrical system.
- If your vehicle is NOT equipped with the Link 800M1074 control panel, consult the original suspension installer for control panel details and fuse locations.

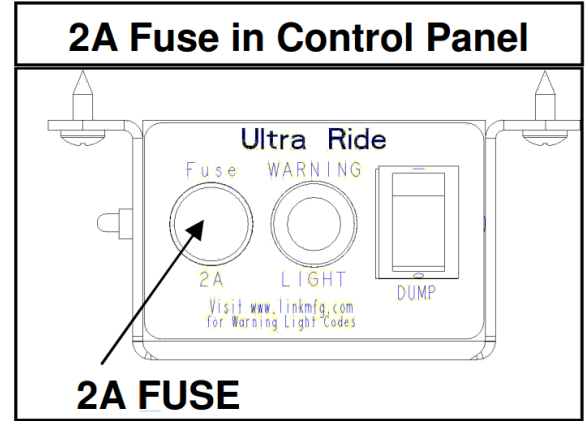

50A Power Fuse

- A 50A fuse is installed between the battery +12V supply power and the Air Kit Vehicle harness.
- This fuse is often near the battery, but can be located elsewhere as determined by the air kit and suspension installer.

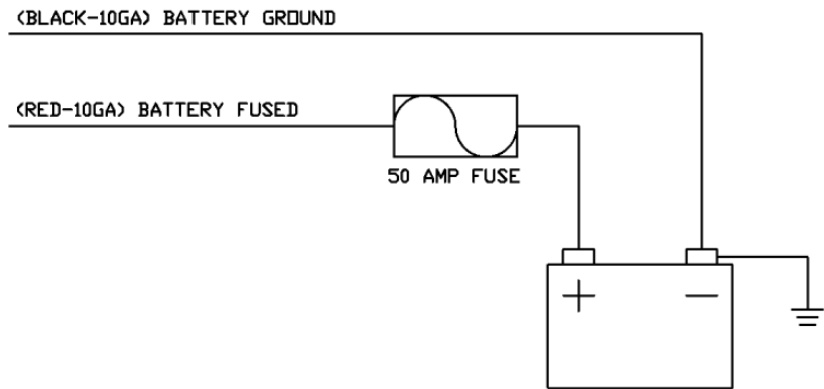

ULTRARIDE® - 800M1400

ELECTRONIC AIR CONTROL KIT

PARTS LIST

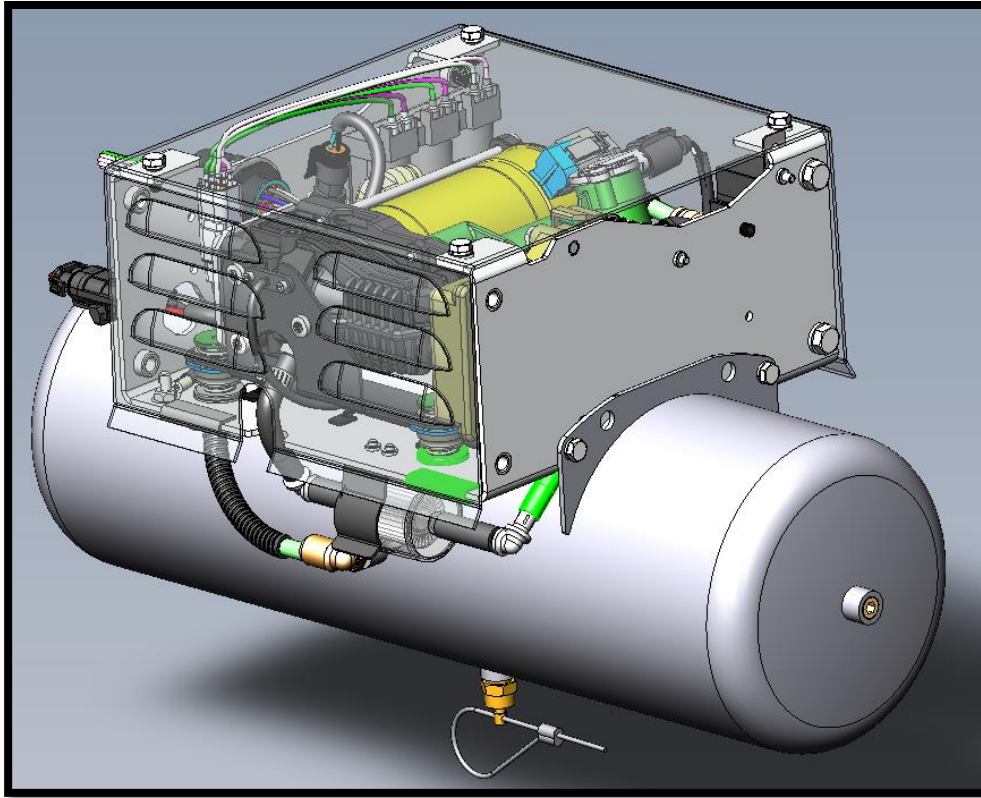

ITEM	PART NUMBER	DESCRIPTION	QTY
1	13010586	INTAKE AIR FILTER KIT	1
2	15051996	POWER HARNESS	1
	15051997	COMMUNICATION HARNESS	
3	800M1402	AIR CONTROL UNIT	1
4	15051998	RELAY	1
5	15051999	ECU	1
6	13034000	AIRLINE-NYLON, 3/8" BULK (FEET)	30
7	15092000	CORRUGATED LOOM, 3/8" BULK (FEET)	30
8	13010587	COMPRESSOR	1
9	13010588	VALVE MANIFOLD	1
SOLD SEPERATELY			
1	800M1071	SENSOR KIT, FORD	2
2	800M1072	SENSOR KIT, RAM	2
3	800M1401	MOUNT KIT	1
4	800M1074	CONTROL PANEL	1
5	13010558	AUTOMATIC DRAIN VALVE KIT	1
6	13010559	HEATED AUTOMATIC DRAIN VALVE KIT	1

ULTRARIDE® - 800M1074

OPTIONAL CONTROL PANEL PARTS LIST

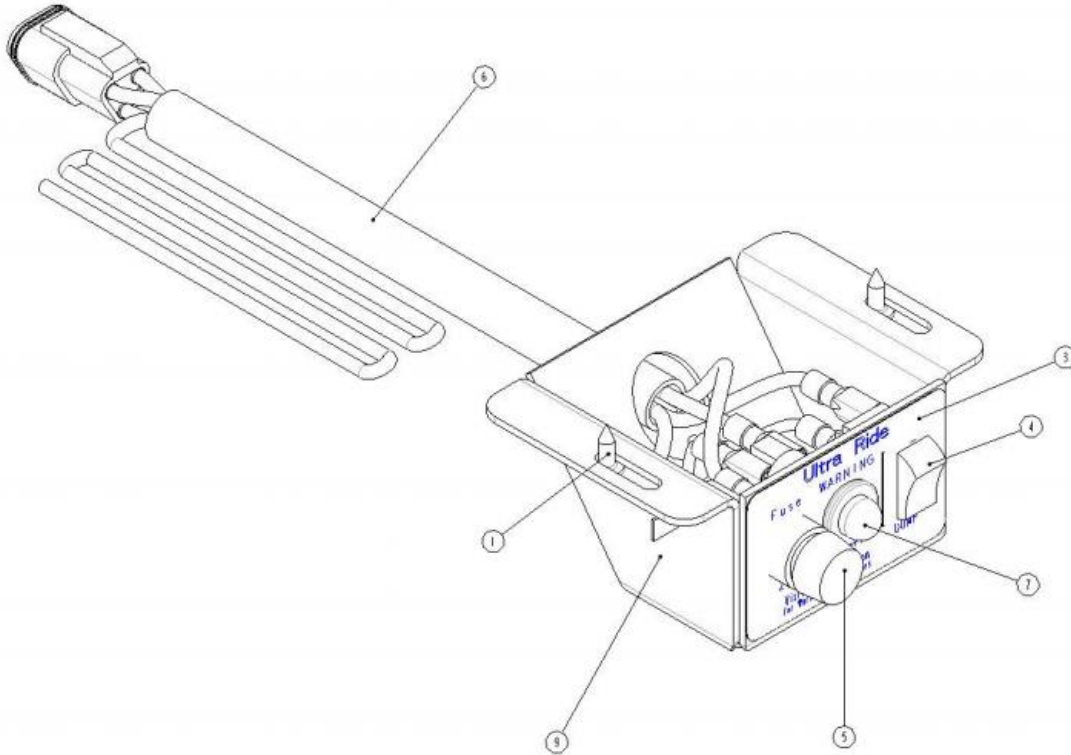

ITEM	PART NUMBER	DESCRIPTION	QTY
1	1459-0C07	NO. 8 X .438 PHIL-PAN SHEET	2
2	1500-1255	BOX(4.25 X 2.5 X 8.00)	1
3	15001828	LABEL-AIR CONTROL, ULTRARIDE	1
4	1505-0207	SWITCH-ROCKER	1
5	1505-1883	FUSE HOLDER,PANEL STYLE	1
6	15050040	HARNES-CONTROL, ULTRARIDE	1
7	15050053	LIGHT-LED, 12V	1
8	15051872	2 AMP FUSE	1
9	80002161	PANEL-MOUNT, SWITCH	1

CHASSIS INTEGRATION WIRING HARNESS ELECTRICAL SCHEMATIC

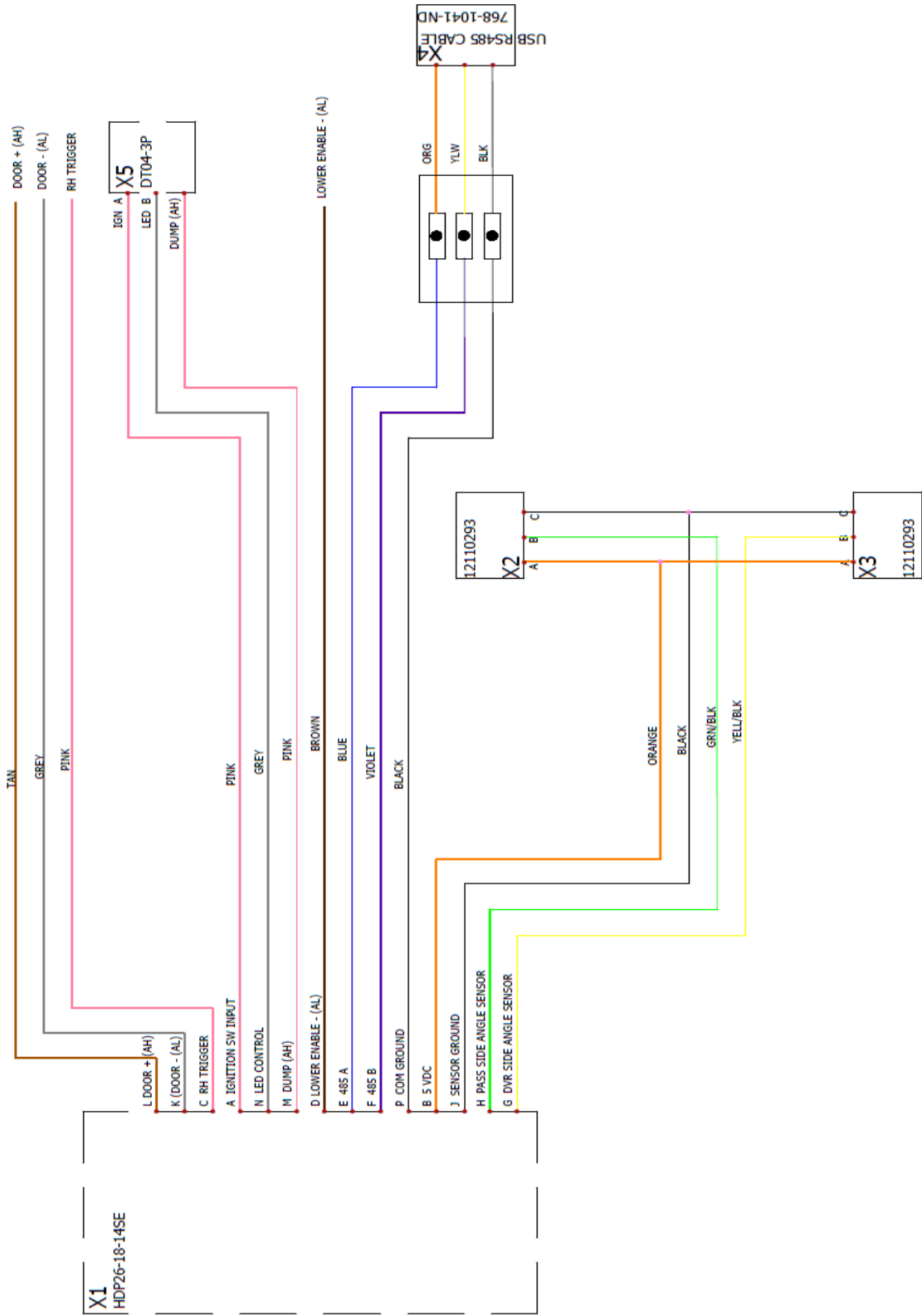

INTERNAL WIRING HARNESS ELECTRICAL SCHEMATIC

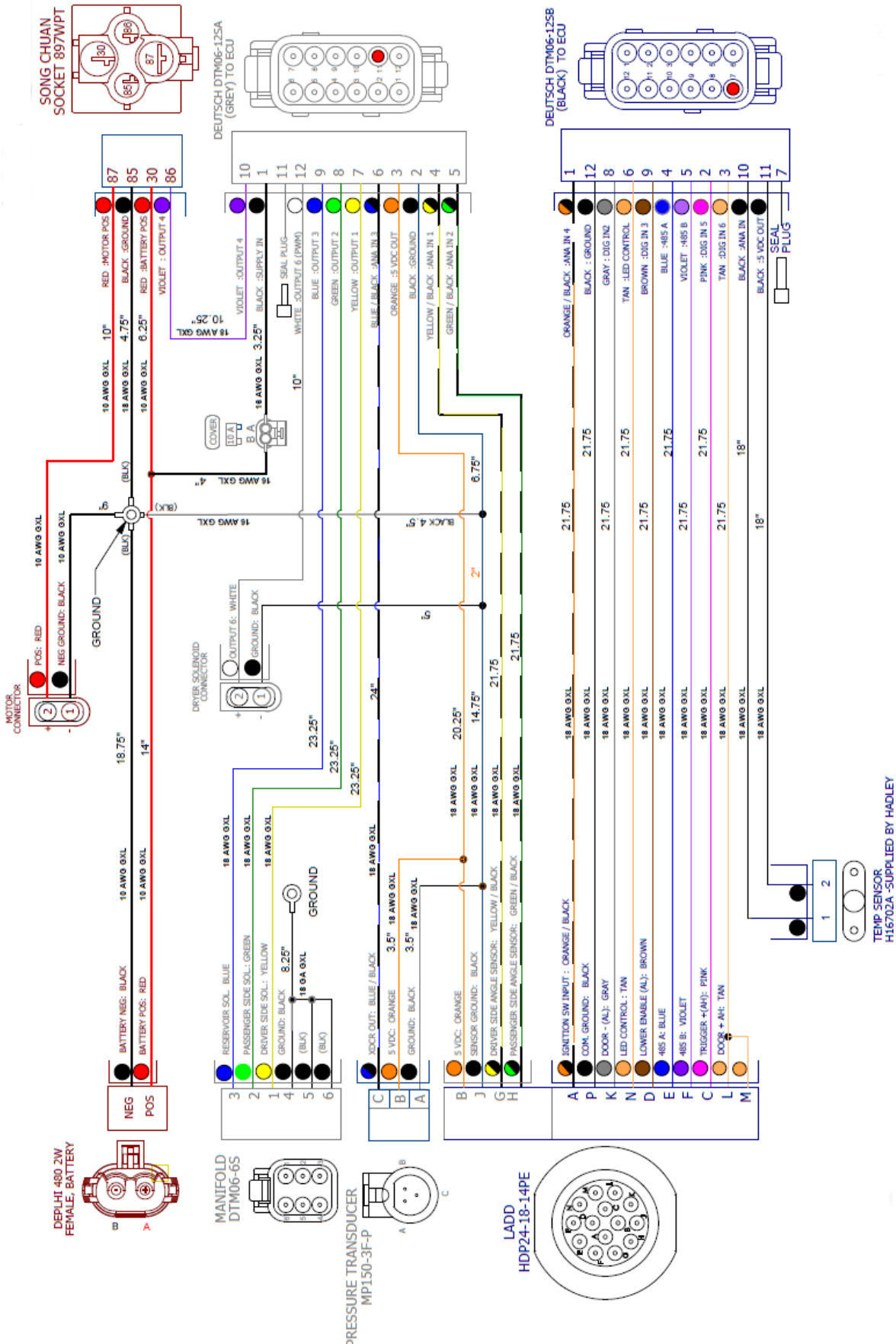

PNEUMATIC SCHEMATIC

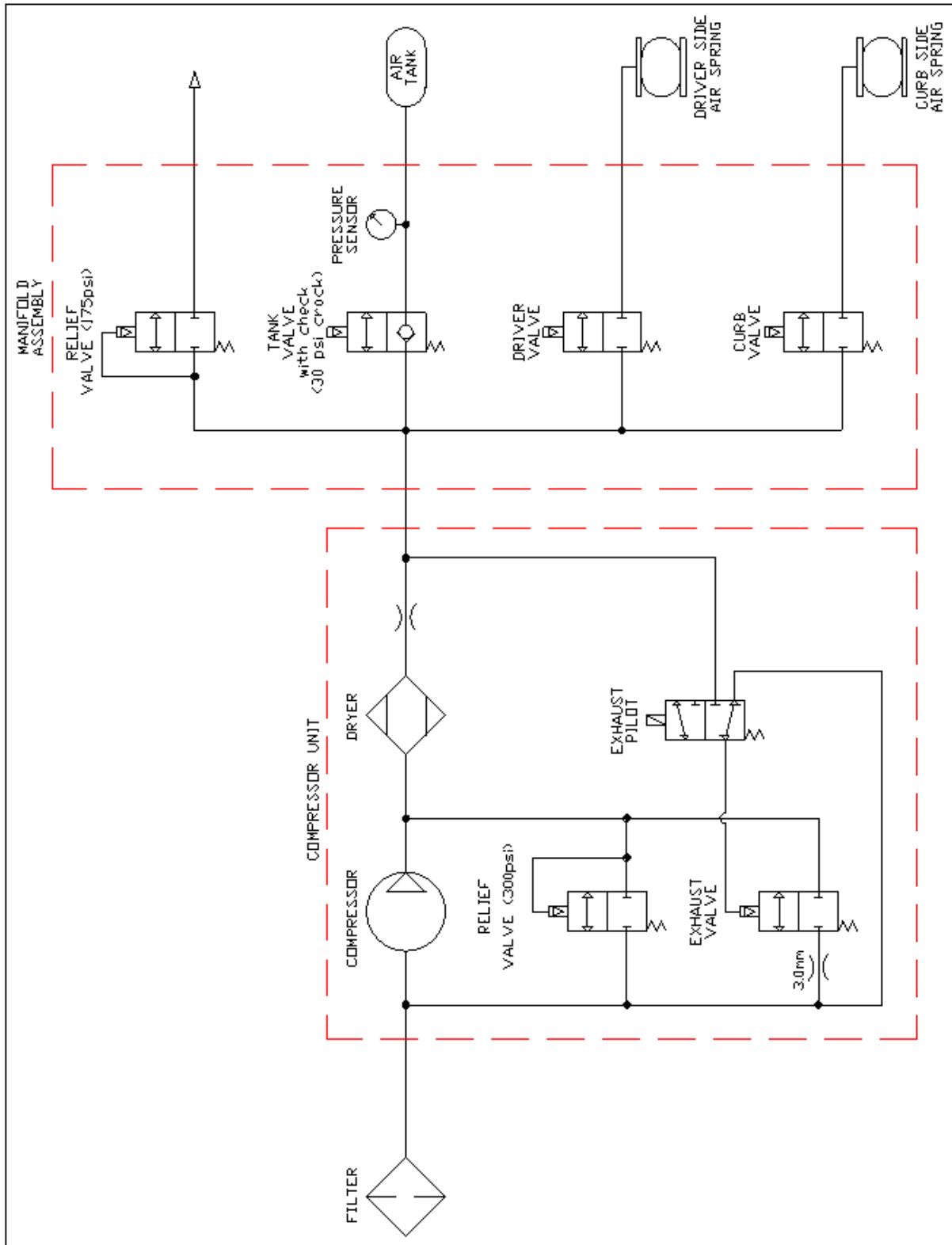

AIR KIT CONTROL PANEL ELECTRICAL SCHEMATIC

Connector:

Duetcsh Series DT Connector
Housing: DT06-3S (QTY 1)
Socket: 1062-16-0122 (QTY 3)
Wedglock: W3S
Pin 1(A) - +12V Ignition Power
Pin 2(B) - Warning Light
Pin 3(C) - Dump Switch

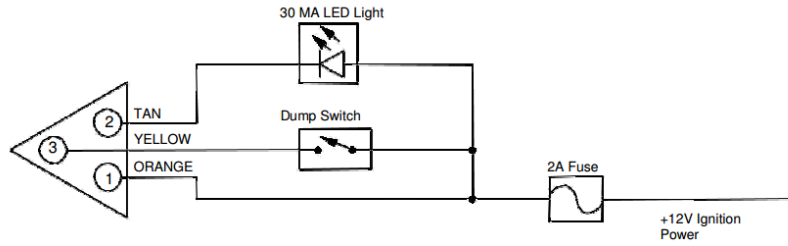

- **NOTE:** The warning indicator light **MUST** be a LED type light with a maximum current draw of **30 milliamps**. An incandescent light or any light exceeding a current draw of 30 milliamps will not function properly.



Link Mfg. Ltd.
223 15th St. NE
Sioux Center, IA USA
51250-2120
(712) 722-4874

<http://www.linkmfg.com>