

# LINK<sup>®</sup> UltraRide<sup>®</sup> Chassis Air Suspension

## ELECTRONIC AIR CONTROL KIT

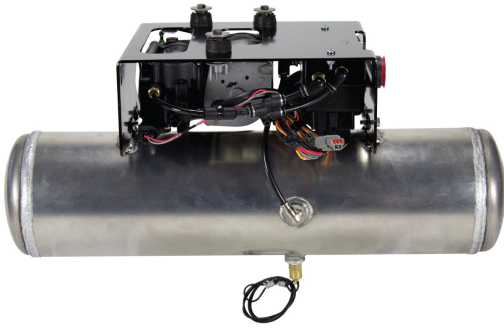

Questions ? Contact this Professional Installer :

Model # 800M1300

Company : \_\_\_\_\_

Lot/Serial # \_\_\_\_\_

Phone : \_\_\_\_\_

Installer : \_\_\_\_\_ Date : \_\_\_\_\_

MN-769

80003011  
MAR 20, 2013

**Please Read this manual before operating your UltraRide  
Suspension, and keep it for future reference.**

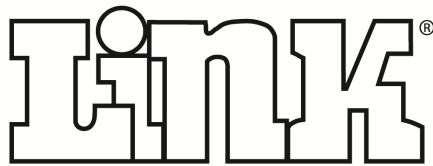

Link Mfg. Ltd.  
223 15th St. NE  
Sioux Center, IA USA  
51250-2120

For questions with your UltraRide suspension system, please call Toll Free 1.800.222.6283

Internet Address: <http://www.linkmfg.com/>

**INNOVATIVE PRODUCTS FOR THE TRANSPORTATION INDUSTRY**

# INDEX

1.0	INTRODUCTION.....	pg. 4
2.0	WARRANTY INFORMATION.....	pg. 6
3.0	AIR SYSTEM OPERATION.....	pg. 8
4.0	SERVICE & MAINTENANCE.....	pg. 10
5.0	TROUBLE SHOOTING GUIDE.....	pg. 12
6.0	FUSES.....	pg. 13

## MISCELLANEOUS INFORMATION

PARTS LISTS.....	pg. 14
ELECTRICAL SCHEMATIC.....	pg. 16
PNEUMATIC SCHEMATIC.....	pg. 19

# 1. INTRODUCTION

Thank you for choosing the Link® **UltraRide®** Electronic Air Control Kit for your vehicle. With no lubrication required and only periodic maintenance as indicated in this manual, your **UltraRide®** system will provide many miles of reliable, trouble free service.

In the unlikely event of a suspension malfunction between regular vehicle maintenance intervals, immediate corrective action should be taken to prevent further suspension damage. Our website, [www.linkmfg.com/ultraride/urdealers.html](http://www.linkmfg.com/ultraride/urdealers.html), can locate a Link dealer near you.

The **UltraRide®** Electronic Air Control Kit is intended ONLY to provide a pressurized air supply for Link **UltraRide®** Chassis Suspensions and control the lift and dump action of the suspension.

**Any other use of these Air Control Products is not authorized. Link Mfg., Ltd. accepts no warranty responsibility for damage resulting from misuse.**

The **UltraRide®** Electronic Air Control Kit provides a convenient and dependable control system for your **UltraRide** suspension system. The Electronic Air Control Kit both provides a source of compressed air for the suspension as well as controls the height of the suspension.





## OWNER RESPONSIBILITIES

The **UltraRide®** Electronic Air Control Kits need no lubrication and requires only a little maintenance as directed in section 3. However, immediate corrective action should be taken if a serious malfunction occurs.

- ❑ Owner is solely responsible for pre-operation inspection, periodic inspections, maintenance, and use of the product as specified in the particular Link Mfg., Ltd. instructions available by product model, except as provided in warranty, and for maintenance of other vehicle components.

- Owner is responsible for all “down time” expenses, cargo damage, and all business costs and losses resulting from a warrantable failure.

### SAFETY SYMBOLS, TORQUE SYMBOL, and NOTES

	This is the safety alert symbol. It is used to alert you to potential personal injury hazards. Obey all safety messages that follow this symbol to avoid possible injury or death.	CAUTION	CAUTION used without the safety alert symbol indicates a potentially hazardous situation which, if not avoided, may result in property damage.
 WARNING	WARNING indicates a potentially hazardous situation which, if not avoided, could result in death or serious injury.	NOTE:	A Note provides information or suggestions that help you correctly perform a task.
 CAUTION	CAUTION indicates a potentially hazardous situation which, if not avoided, could result in minor or moderate injury.		The electrical symbol indicates the presence of electric shock hazards which, if not avoided, may result in injury to personnel or damage to equipment.

5

## LINK<sup>®</sup> LIMITED WARRANTY ULTRARIDE<sup>®</sup> ELECTRONIC AIR KIT 800M1300

### What Is Covered

This warranty covers any defects in materials or manufacture. This warranty does not cover ordinary wear and tear, routine maintenance, or damage caused by alteration or improper installation, use, or maintenance of the Product.

### How Long Coverage Lasts

For all components including the air compressor, this warranty runs for 3 years from the date the Product was sold to its original end-user (the “Sale Date”) or 60,000 miles, whichever occurs first.

### What Link Will Do

Link will repair or replace any Product that does not conform to this warranty. Link will also reimburse for installation of repaired or replacement parts as follows:

Labor Description	Hours	Hourly Rate
Diagnostic	0.5	\$75
Power pack / component replacement	1.0	\$75
Height sensor (1) replacement	1.0	\$75

6

## How To Get Warranty Service

**Telephone Link Customer Service at 1-800-222-6283.** You may also take the Product to any authorized Link distributor or dealer. You will be responsible for removing the Product from the vehicle and shipping it to Link at your expense. You must submit documentation of the date and vehicle mileage when the Product was sold to its original end-user and the vehicle's current mileage.

## Limitations & Exclusions

Link will not be responsible for incidental or consequential damages, including loss of use or profits.

### **LINK DISCLAIMS ANY WARRANTY OF MERCHANTABILITY OR FITNESS FOR A PARTICULAR PURPOSE.**

This warranty does not apply if the Product is used with accessories not approved by Link or when other than Link Genuine Replacement Parts have been installed on the Product.

Link does not warrant accessories supplied by Link that bear the name of another company.

Link reserves the right to provide refurbished parts in response to a warranty claim.

Parts supplied in response to a warranty claim are warranted only for the remainder of the original warranty period.

9/1/2011

7

## 2. AIR SYSTEM OPERATION

The **UltraRide®** Electronic Air Control Kit keeps the suspension at a consistent level by controlling the pressure of air in each air spring. Height sensors feed position information to the ECU (electronic control unit) which controls a set of valves to either add or remove air from the air springs.

The **UltraRide®** Electronic Air Control Kit is programmed to dump the air in the suspension to a specific height, to improve ingress & egress accessibility for various vehicles. By dumping to a height, air is conserved, improving compressor life recovery time. This Dump Height can be adjusted. See your local Link Mfg. Service Representative for details.

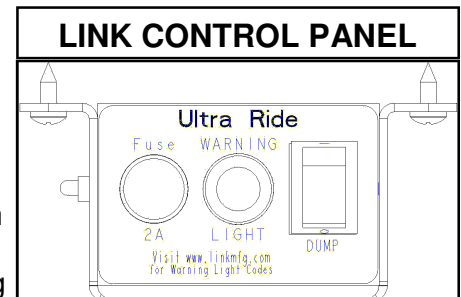

## **Warning Light**

The **UltraRide®** Control panel includes a warning light showing the system status.

### **Normal Operation Mode** (Warning Light Remains off)

- ❑ During normal driving operation, the system maintains suspension Ride Height and does not require any user input.
- ❑ Tank Pressure is maintained between 120 & 155 psi.

### **Dump Mode** (Warning Light is ON)

- ❑ To dump or lower the suspension, activate the dump switch (note: depending on the application, there may be multiple ways to activate the dump mode, e.g. opening the rear doors of an ambulance)

8

- The electronic air control kit will dump the suspension to a pre-programmed height and hold it there, maintaining some air pressure in the air springs.



**CAUTION!!!!** The **vehicle should NOT be driven** while the suspension is dumped. Doing so can result in damage to the suspension and/or the vehicle.

- Tank Pressure is maintained between 120 and 155 psi. so it is ‘topped off’ and ready for dump recovery.

## Deactivating (Exiting) Dump Mode

- To exit Dump Mode and return to normal operation with the suspension at Ride Height, first disable all dump switch(es). Then, press the vehicle brake pedal.
- NOTE: The suspension will NOT return to normal Ride Height until the brake pedal is depressed.

## Setting Suspension Ride Height

- The suspension Ride Height is set by the installer, but should be checked and maintained periodically.
- Power up the electronic air control kit and allow the air tank to reach full pressure (the compressor is off).
- Measure Ride Height as specified in your **UltraRide®** suspension manual and adjust the magnet on each side of the suspension, lowering the magnet to reduce Ride Height and raising the magnet to increase Ride Height.
- Between adjustments wait until the suspension has settled down and recheck the Ride Height settings.
- After Ride Height for both sides has been set, activate the suspension dump, deactivate the dump, and recheck the Ride Height. Repeat the above steps until the correct Ride Height has been achieved.

9

# 3. SERVICE & MAINTENANCE

The **UltraRide®** Electronic Air Control Kit needs no lubrication and little maintenance. The following components should be checked at the time the truck is being serviced. However, immediate corrective action should be taken if a serious malfunction occurs.



**CAUTION!** If maintenance or service is to be done on the air system, be sure to drain **all** air from system. Serious injury could occur if components are removed while system is full of air.

## It is important to release any moisture contained within the air reservoir weekly!

Even with the advanced features of the electronic air kit system along with accessories like air dryers, moisture can build up in the air tank and should be checked.

This can be done by pulling on the cable attached to the drain valve. Not releasing the moisture on a regular basis will cause the drain valve to operate improperly, and may cause the air kit to malfunction. Excess moisture in the system can also cause premature failure of other components including the tank itself.

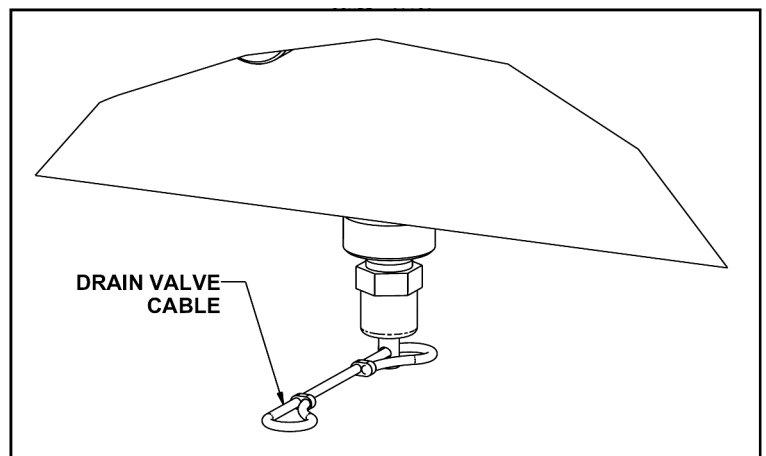

10

## Operational Notes:

- The Warning light:
  - Solid on: Suspension is Dumped and vehicle should not be driven.
  - Blinking: There is an error and the vehicle should not be driven.
- A minimum tank pressure of 120 psig is required for the system to recover from a suspension dump. The Air Control Kit will not dump if there is not sufficient pressure to recover.

## EVERY Week

- Manually drain excess moisture from tank.

## EVERY 3,000 miles or every oil change:

- Check for air leaks around fittings.
- Check air filter; replace if necessary.
- Check for debris on magnet and clean if necessary.

## EVERY 30,000 miles or 6 months, whichever comes first:

- Replace the air filter.

11

# 4. TROUBLESHOOTING

Problem / Symptom	Possible Causes	CORRECTIVE ACTIONS
<b>Air Tank Leaks down*</b>	A. Fittings on air tank leaking B. Damaged Airline to tank C. Faulty Valve manifold	A. Tighten or replace fittings B. Replace Damaged Airline C. Replace valve manifold
<b>Air Spring(s) Leaks down*</b>	A. Fittings on Air Spring Leaking B. Damaged Air Spring C. Damaged airline to air spring D. Faulty Valve manifold	A. Tighten or replace fittings B. Replace air spring C. Replace damaged airline D. Replace valve manifold
<b>Compressor does not run</b>	A. Ignition Key is not on B. Fuse(s) blown C. Tank is full	A. Turn on the ignition key to power the system B. Check and replace fuses. C. Nothing wrong, normal operation
<b>Compressor runs too much</b>	A. Leak in system B. Plugged Air Filter C. Faulty Compressor	A. Find and stop leak B. Replace Air Filter C. Replace Compressor
<b>Suspension does not dump</b>	A. Ignition Key is not on B. Improper height settings C. Loose connections D. Air Tank Pressure is Low	A. Turn on the ignition key to power the system B. See manual to program the height settings C. Check all electrical connections. D. Allow time for compressor to fill tank.
<b>Suspension does not recover after dump</b>	A. Brake pedal not pressed B. Brake input not properly connected	A. Press the vehicle brake pedal B. Check installation & wiring of brake input wire
<b>Warning Light is on</b>	A. Suspension is dumped	A. Nothing wrong, normal operation.
<b>Warning light is blinking</b>	A. Error or System Malfunction	A. Use the Link Air Tools Diagnostic Software to diagnose cause of error.

\* NOTE: All air systems will always have some inherent leaks and will, over a long period of time, leak down.

# 5. FUSES

## 2A Fuse in Control Panel

- If your vehicle is equipped with the Link 800M1074 control panel, there is a 2A fuse located in that control panel between the ignition power and rest of the air kit electrical system.
- If your vehicle is NOT equipped with the Link 800M1074 control panel, consult the original suspension installer for control panel details and fuse locations.

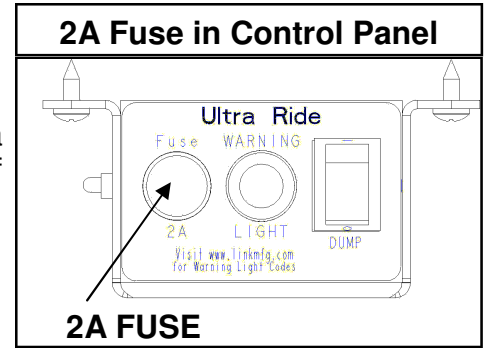

## 40A Power Fuse

- A 40A fuse is installed between the battery +12V supply power and the Air Kit Vehicle harness on the AL002A (RED-8GA) wire.
- This fuse is often near the battery, but can be located elsewhere as determined by the air kit and suspension installer.

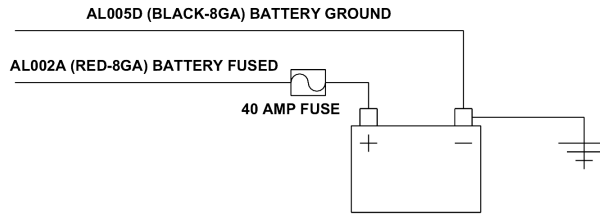

13

# ULTRARIDE® - 800M1300 ELECTRONIC AIR CONTROL KIT PARTS LIST

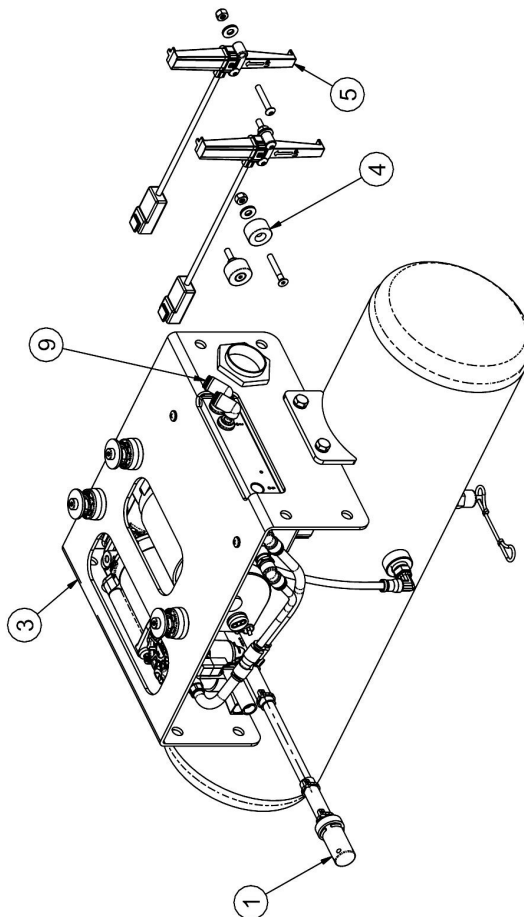

14

ITEM	PART NUMBER	DESCRIPTION	QTY
1	13010585	INTAKE AIR FILTER KIT	1
2	13010581	CHASSIS INTEGRATION HARNESS	1
3	13010582	AIR CONTROL UNIT AND HARNESS	1
4	13010583	MAGNET KIT	2
5	13010584	SENSOR KIT	2
6	13020090	AIRLINE-NYLON, 1/4" BULK (FEET)	30
7	13034000	AIRLINE-NYLON, 3/8" BULK (FEET)	15
8	15000435	CORRUGATED LOOM, 1/4" BULK (FEET)	30
9	13025499	ELBOW-PLUG-IN, 1/4"	2

# ULTRARIDE® - 800M1074 OPTIONAL CONTROL PANEL

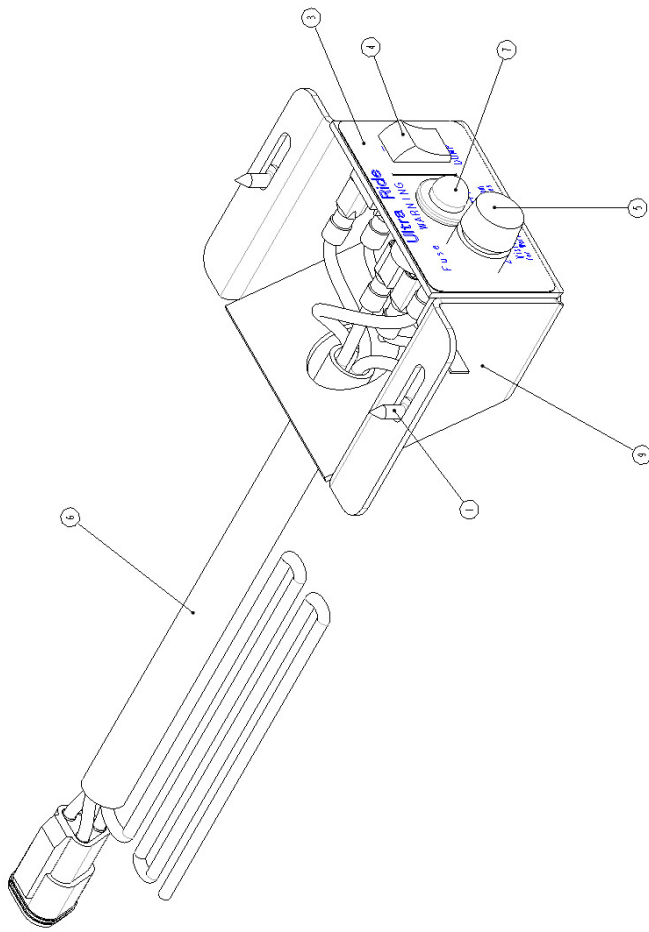

ITEM	PART NUMBER	DESCRIPTION	QTY
1	1459-0C07	NO. 8 X .438 PHIL-PAN	2
2	1500-1255	BOX(4.25 X 2.5 X 8.00)	1
3	15001828	LABEL-AIR CONTROL, UL-TRA RIDE	1
4	1505-0207	SWITCH-ROCKER	1
5	1505-1883	FUSE HOLDER,PANEL	1
6	15050040	HARNES-CONTROL, UL-TRARIDE	1
7	15050053	LIGHT-LED, 12V	1
8	15051872	2 AMP FUSE	1
9	80002161	PANEL-MOUNT, SWITCH	1

15

## Chassis Integration Wiring Harness Electrical Schematic

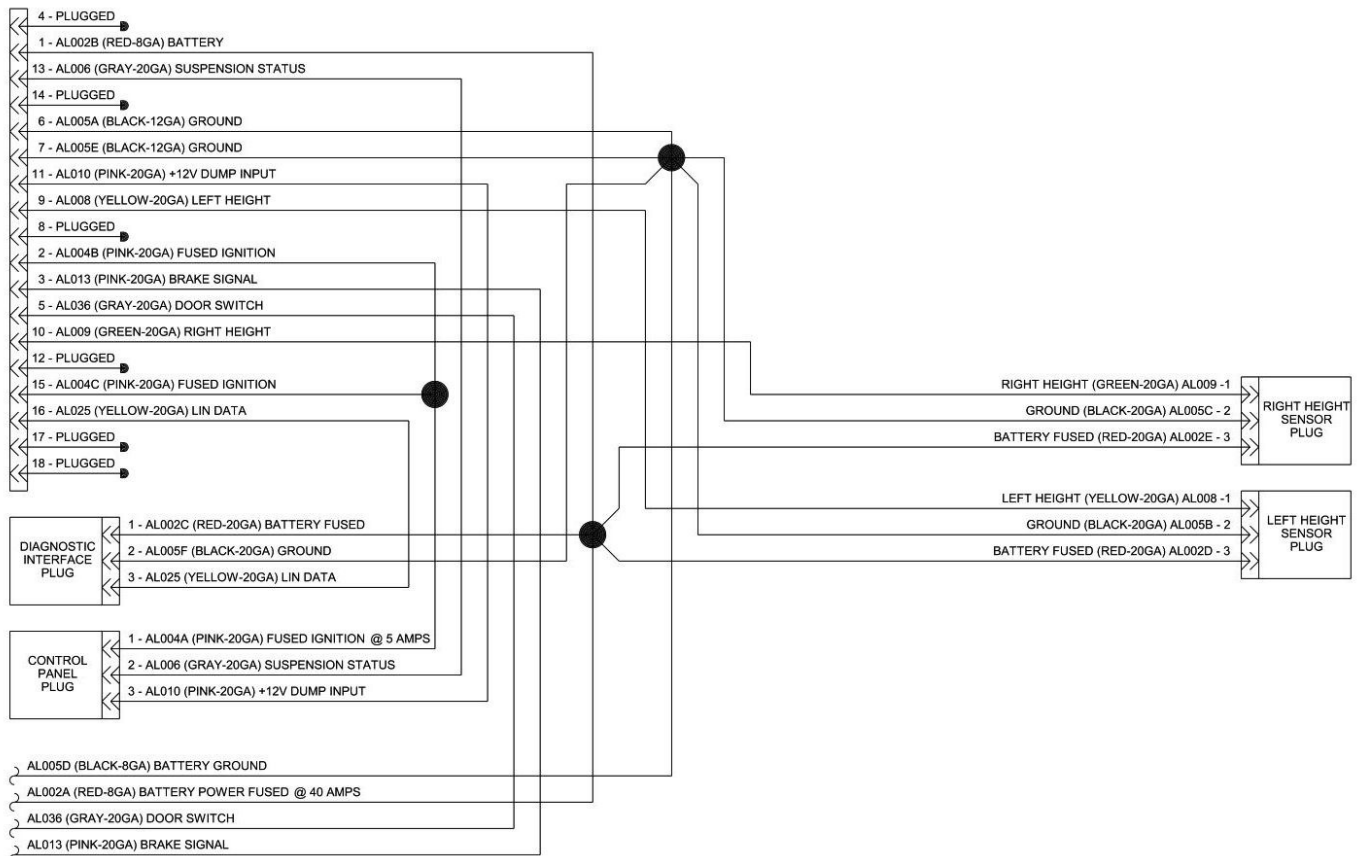

16



# Internal Wiring Harness Electrical Schematic

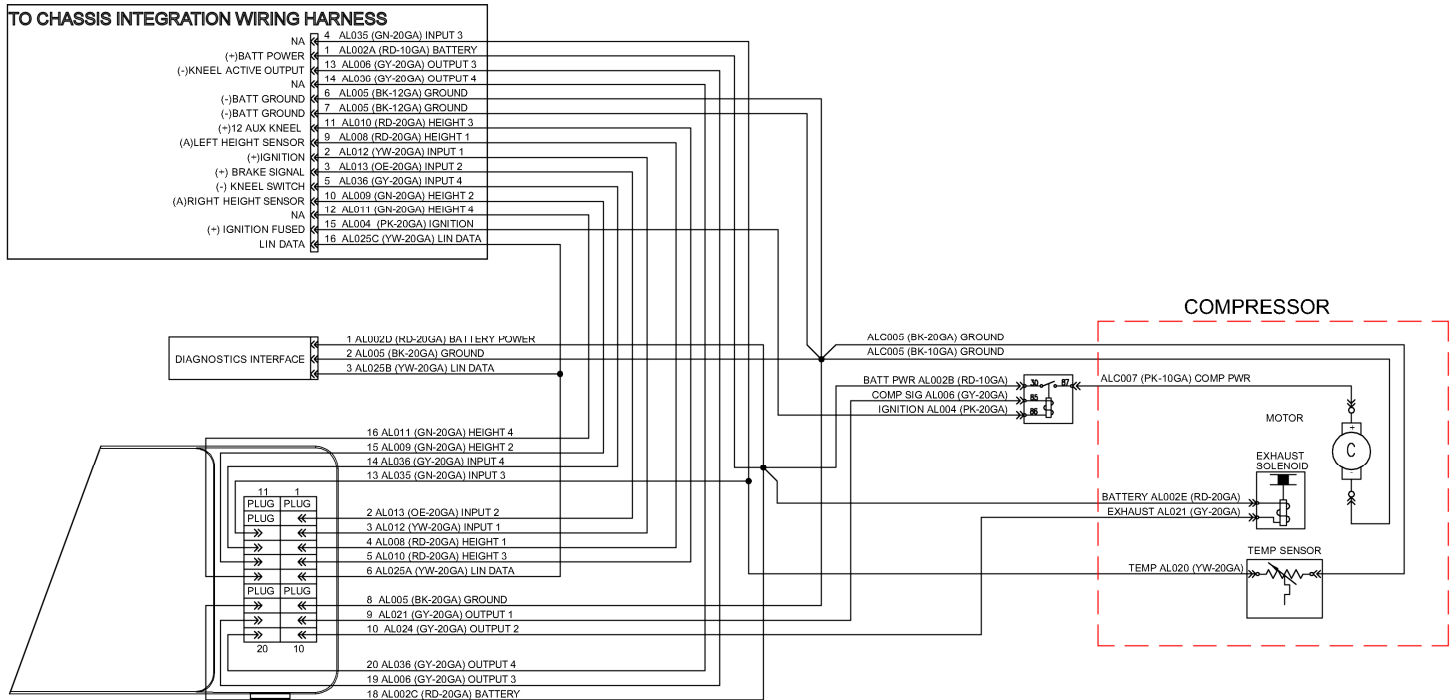

17

# Air Kit Control Panel Electrical Schematic

Connector:

Duetsch Series DT Connector

Housing: DT06-3S (QTY 1)

Socket: 1062-16-0122 (QTY 3)

Wedgelock: W3S

Pin 1(A) - +12V Ignition Power

Pin 2(B) - Warning Light

Pin 3(C) - Dump Switch

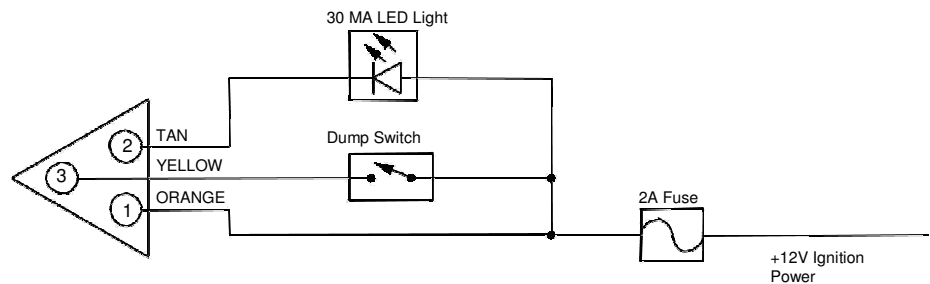

- NOTE: The warning indicator light MUST be a LED type light with a maximum current draw of **30 milliamps**. An incandescent light or any light exceeding a current draw of 30 milliamps will not function properly.

18

# Pneumatic Schematic

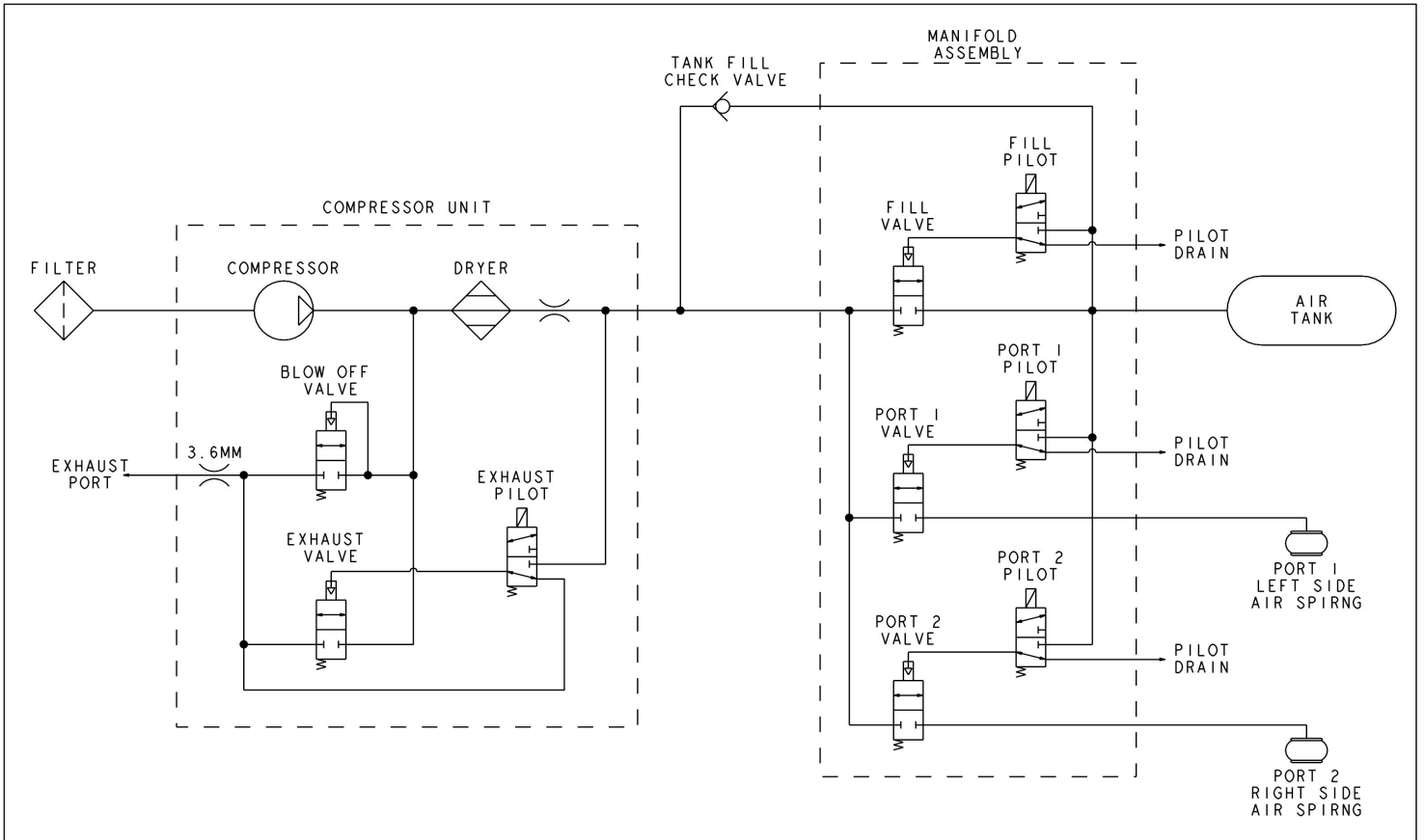

19

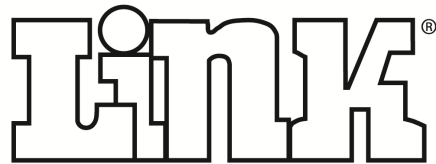

Link Mfg. Ltd.  
 223 15th St. NE  
 Sioux Center, IA USA  
 51250-2120

(712) 722-4874

<http://www.linkmfg.com/>