

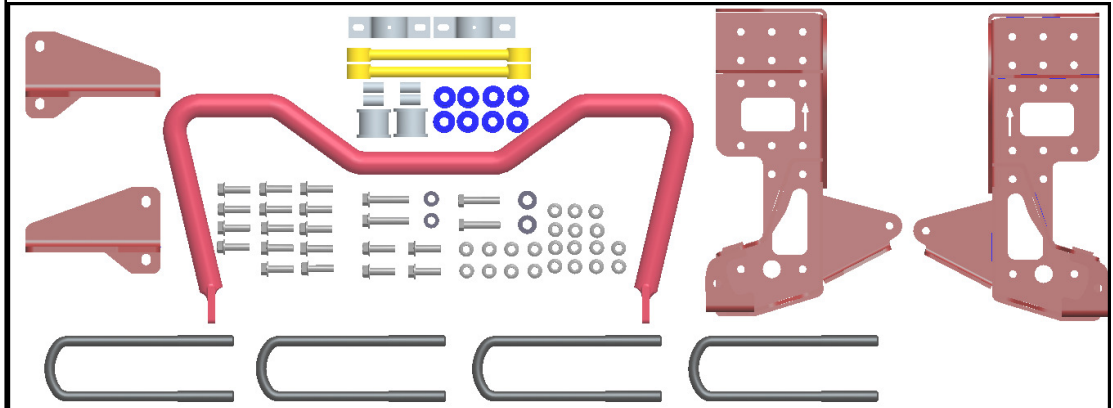

**GM C4500/C5500 4X2
STABILIZER BAR RE-INSTALLATION KIT
2003-NEWER MODELS**

For Installation with 8M000087 & 8M000090
UltraRide Suspensions

Link Kit Part Number: 800M1053



Questions? Contact this Professional Installer :

Company : _____

Phone : _____

Installer : _____ Date : _____

1. INTRODUCTION

NOTE: It is important that the entire installation instructions be read thoroughly before proceeding with suspension installation.









WARNING! A correct installation must result in the suspension and axle being “loaded” within the range specified by axle and suspension manufacturers. Please check vehicle specifications and intended usage to insure axle will be within Gross Axle Weight Rating (GAWR). No alteration of any suspension component is permitted. Link Mfg. Is not responsible for damages from improper installation or operations beyond design capability. Link Mfg. In its sole discretion shall determine whether or not any product is defective or otherwise covered by warranty.

PRODUCT INSTALLER RESPONSIBILITIES

- ❑ Installer is responsible for installing the product in accordance with Link Mfg. specifications and installation instructions.
- ❑ Installer is responsible for providing proper suspension to vehicle attachments.
- ❑ Installer is responsible for assuring necessary clearance for vehicle and suspension components, such as axle, wheels, tires, exhaust, and air springs to ensure safe operation.
- ❑ Installer is responsible for advising the owner of proper use, service and required maintenance, and for supplying maintenance and other instruction supplied by Link Mfg.

SAFETY SYMBOLS, TORQUE SYMBOL, and NOTES

	This is the safety alert symbol. It is used to alert you to potential personal injury hazards. Obey all safety messages that follow this symbol to avoid possible injury or death.		The torque symbol alerts you to tighten fasteners to a specified torque value.
 WARNING	WARNING indicates a potentially hazardous situation which, if not avoided, could result in death or serious injury.	NOTE:	A Note provides information or suggestions that help you correctly perform a task.
 CAUTION	CAUTION indicates a potentially hazardous situation which, if not avoided, could result in minor or moderate injury.		The electrical symbol indicates the presence of electric shock hazards which, if not avoided, may result in injury to personnel or damage to equipment.
CAUTION	CAUTION used without the safety alert symbol indicates a potentially hazardous situation which, if not avoided, may result in property damage.		Proper tightening of U-Bolt nuts and mounting nuts are required for proper operation. Need for proper Torque value is indicated by wrench symbol and values will be found in Table 10-1 in the Final Assembly section of the instructions. Failure to maintain proper torque can cause component failure resulting in accident with consequent injury.

INSTALLATION NOTES:

- ❑ Proper tightening of U-Bolt nuts and frame mounting nuts is required for proper operation. Critical torque values are indicated by a wrench symbol. Required torque values are located Torque Table in section 7. **Failure to maintain proper torque may cause component failure and may result in accident with consequent injury.**
- ❑ When installing the UltraRide suspension on the GM chassis, please reference the appropriate sections of the GM Service Manual for additional requirements.
- ❑ The OE stabilizer bar is not required with the UltraRide suspension. However, if desired, a rear stabilizer bar kit is available from Link Mfg. (Part Number 800M1053).

PRE-INSTALLATION CHECKLIST

- ❑ Check the vehicle wheel alignment prior to installation to insure no precondition already exists; record the information for verification.
- ❑ Remove the attached body, if necessary. Remember to disconnect all electrical connections to the body, and fuel filler tube, before removing the body. The installation may also be completed using a lift to raise the vehicle. If using a lift, chassis body removal may not be necessary. Removal of rear wheels will aid in installation. *Refer to GM Document 812944 and 827666.*
- ❑ When installing the suspension without using a lift:
 - ❑ Block the front wheels (both sides, front and rear of tire) and apply the emergency brake so the vehicle cannot roll.
 - ❑ Do not lift the wheels off the ground.
 - ❑ Do not jack on any part of the axle.

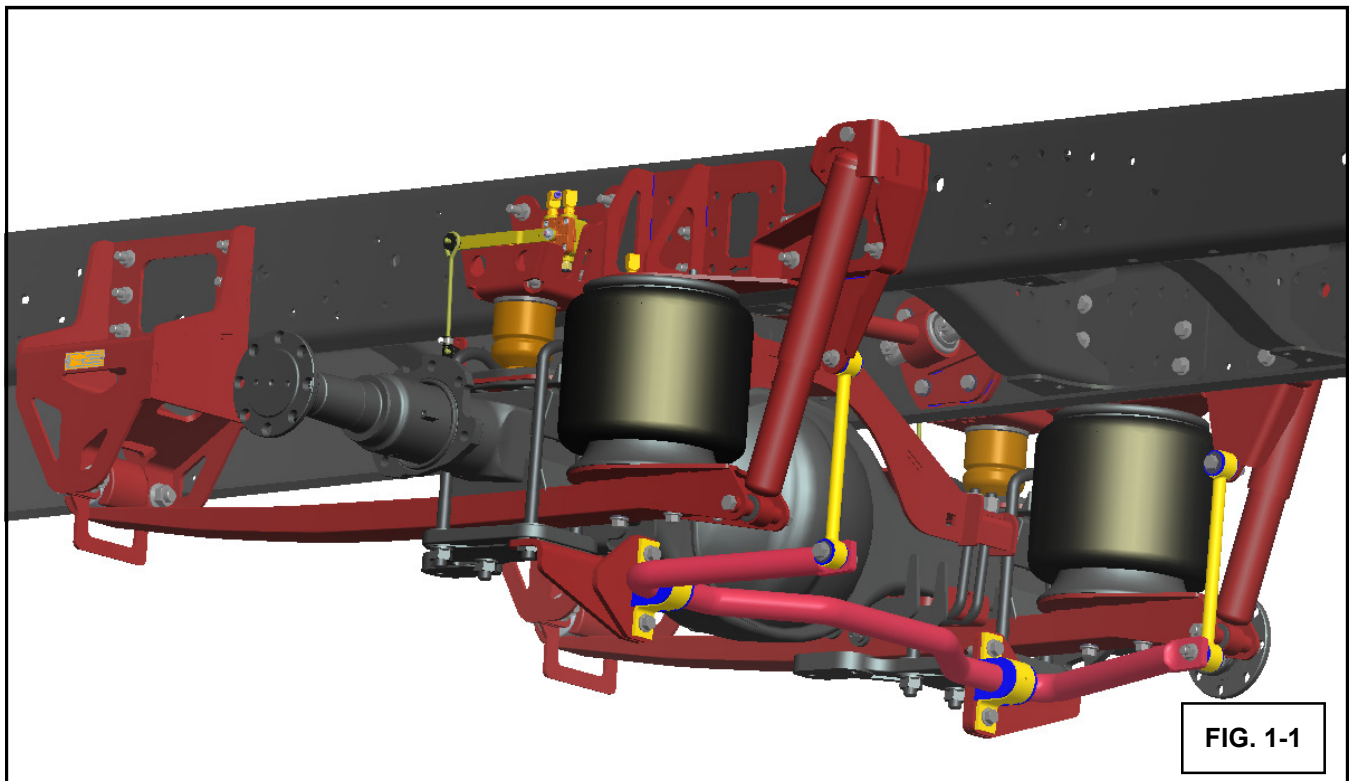

2. REMOVAL AND INSTALLATION

1. Verify that the vehicle needs the new air spring brackets. If your current installed air spring bracket does not have the upper stabilizer mount

shown (Fig. 2-1), discard and replace with supplied left and right upper air spring brackets. Utilize the 1411-1614 bolts and 1480-1604 nuts supplied with the kit to fasten the new brackets to the frame.

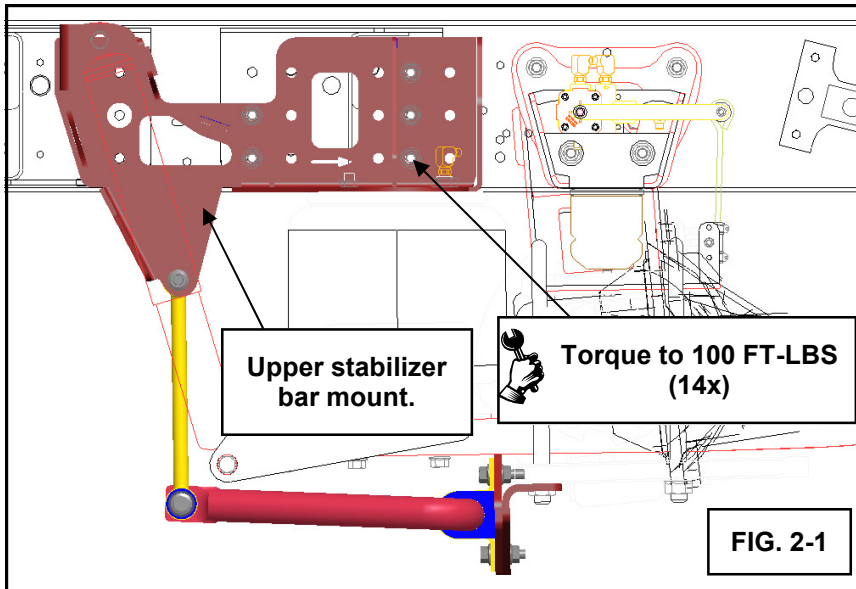

2. Torque the 14 fasteners to **100 FT-LBS.**

3. Remove and discard axle mount U-bolts. Install stabilizer bar mount brackets using new U-bolts supplied.

NOTE: The free spinning lock nuts can be re-used.

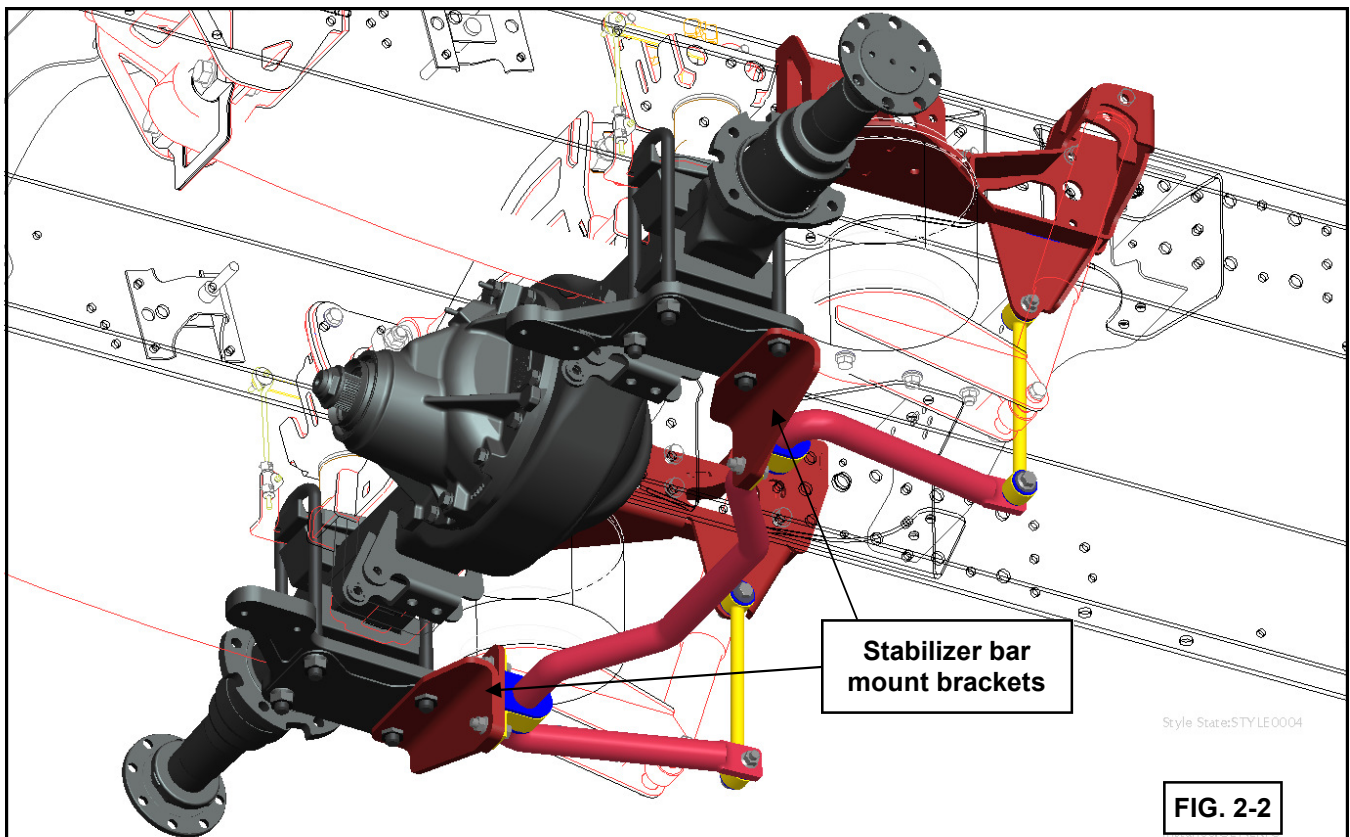

-  4. Torque the free spinning lock nuts on the U-bolts to **315 FT-LBS** via torque sequence shown below.

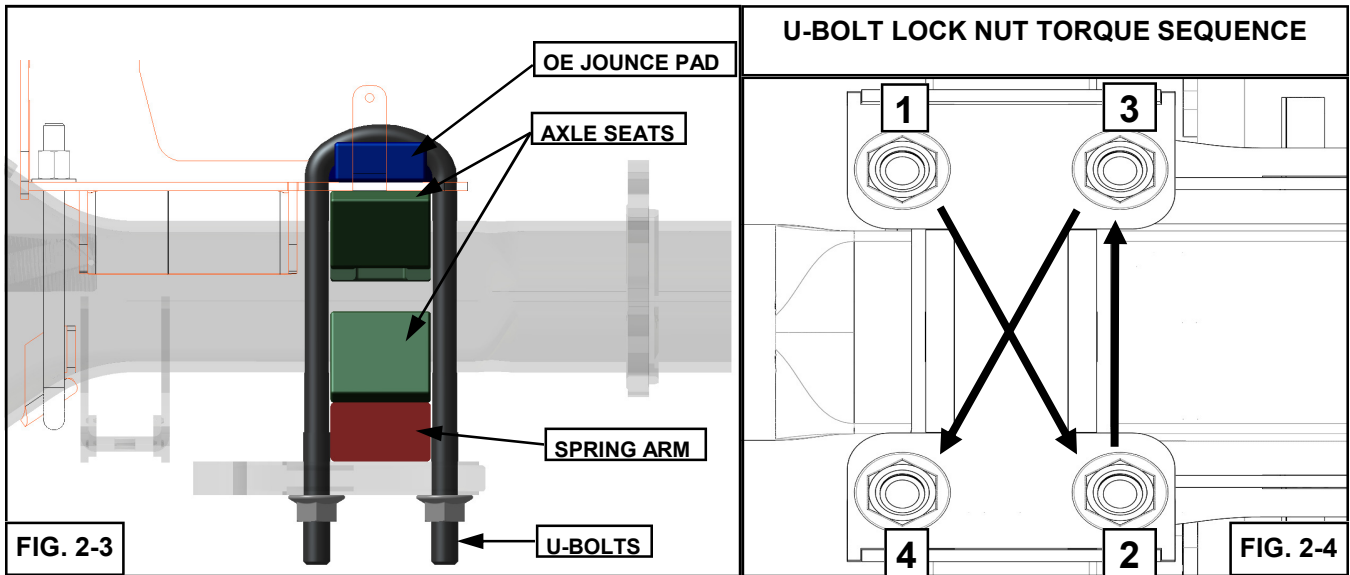

5. Pre-assemble bushing and clamp loosely to stabilizer bar (Fig. 2-5).
6. Assemble the stabilizer bar to the axle brackets using the 1411-1614 bolts and 1480-1604 nuts as shown on (Fig. 2-5).
-  7. Torque the four fasteners to **100 FT-LBS**.

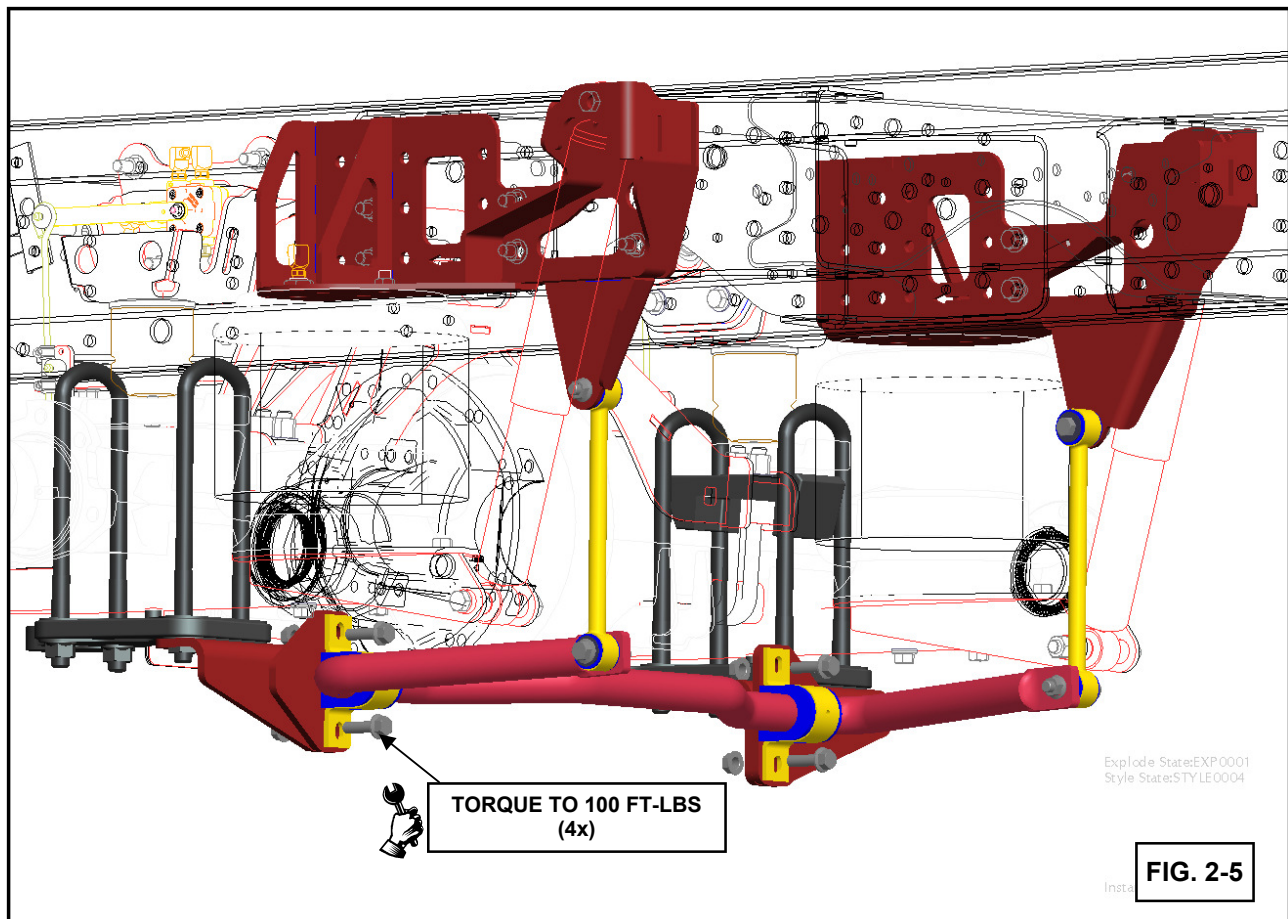

9. Bolt links (Fig. 2-6) to the stabilizer bar using 141A-1622 bolts and 1480-1604 nuts.
10. Then align and bolt the link to the upper stabilizer bar bracket using 1402-1620 bolt and 1480-1604 nuts.
11. Torque the four fasteners to **100 FT-LBS**.
12. Verify all hardware is utilized and all fasteners are torque to proper values.
13. Test drive and inspect vehicle to verify proper installation and function.

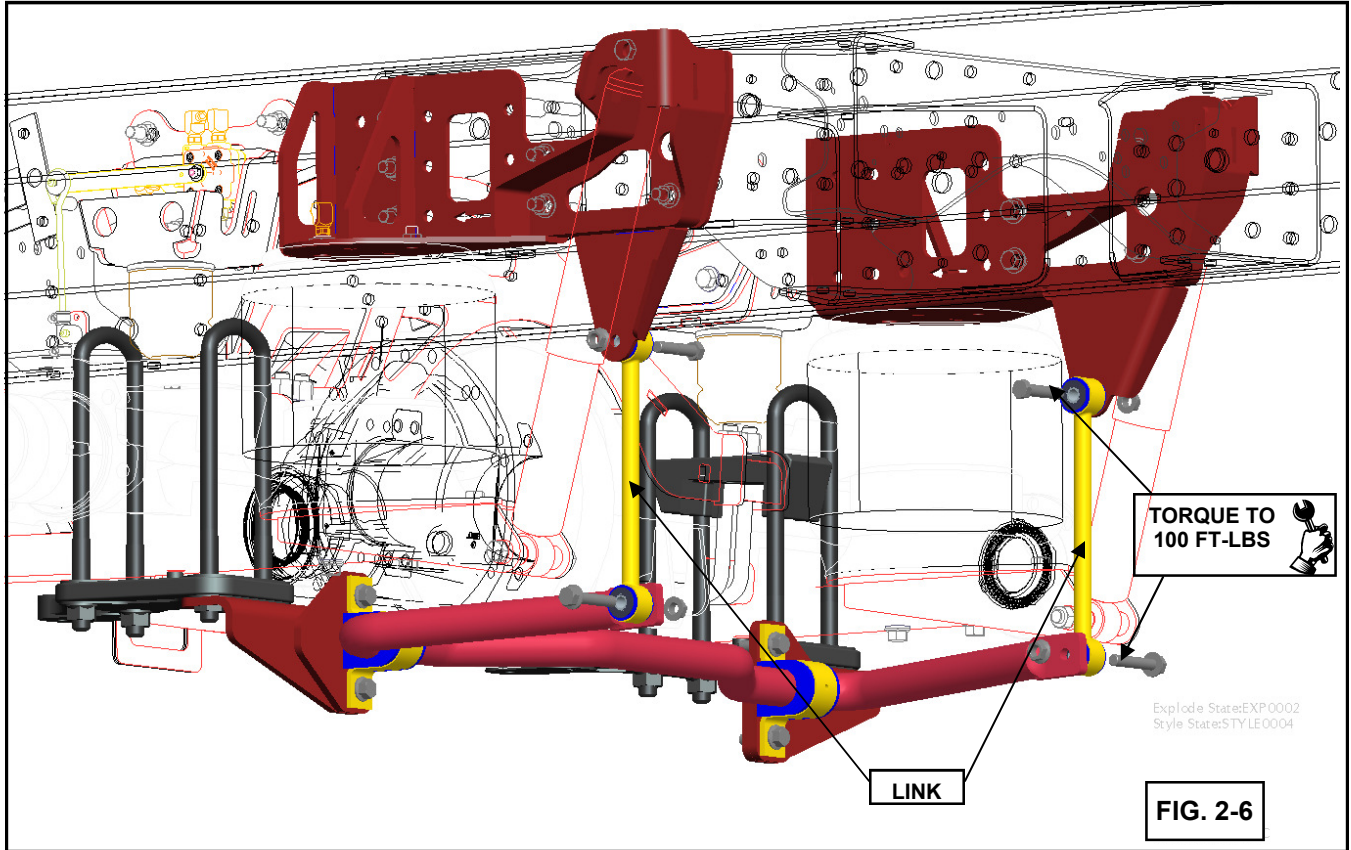

TORQUE TABLE		
LOCATION	FASTENER	TORQUE
TRAILING ARM AXLE LOCATION	M20 FLANGE NUTS (U-BOLT)	275 FT-LBS
SWAY BAR MOUNT BRACKET	1/2 UNC NUTS	100 FT-LBS
AIRSPRING BRACKET TO CONNECTING LINK	1/2 UNC NUTS	100 FT-LBS
STABILIZER BAR TO CONNECTING LINK	1/2 UNC NUTS	100 FT-LBS
FRAME MOUNTED UPPER AIRSPRING BRACKET	1/2 UNC NUTS	100 FT-LBS

3. OPERATION & MAINTENANCE

The UltraRide® Rear Stabilizer Kit needs no lubrication and little maintenance. The following components should be checked at the time the vehicle is being serviced. However, immediate corrective action should be taken if a serious malfunction occurs. See the Parts List Drawing on following page for details.



WARNING! If maintenance or service is to be done on the air system, be sure to drain **all** air from system. Serious injury could occur if components are removed while system is full of air.

PRODUCT OWNER RESPONSIBILITIES

- ❑ Owner is solely responsible for pre-operation inspection, periodic inspections, maintenance, and use of the product as specified in the particular LINK MFG. instructions available by product model, except as provided in this warranty, and for maintenance of other vehicle components. Of particular importance is the re-torque of fasteners including axle u-bolts, torque rod bolts and track rod bolts. This re-torque must be performed within 90 days of the suspension being put in service.
- ❑ Owner is responsible for “down time” expenses, cargo damage, and all business costs and losses resulting from a warrantable failure.
- ❑ The UltraRide® Chassis Air Suspension is fully automatic in controlling the height of the chassis. No manual intervention to control air pressure or ride height is needed during the course of operation.

CHECK AFTER THE FIRST 1000 MILES:

- ❑ Recheck & tighten any loose fasteners.
- ❑ Check for any loose or worn components.

CHECK AFTER EVERY 30,000 MILES:

- ❑ Check stabilizer bar pivot bushings and connecting link bushings for wear; replace if worn.

***UltraRide* – GM C4500/C5500**

STABILIZER BAR RE-INSTALLATION KIT

ITEM	PART #	DESCRIPTION	QTY
1	1402-1620	1/2 X 2 1/2 UNC HEX CAP SCR (GR 8)	2
2	1411-1614	1/2 X 1 3/4 UNC FLANGE BOLT (GRADE 8)	18
3	141A-1622	1/2 X 2 3/4 UNC FLANGE BOLT (GR 8) O&P	2
4	1480-1604	1/2 UNC TOP LOCK FL NUT (GR G) O&P	22
5	1488-1602	1/2 SAE HARDENED WASHER	2
6	1488-2003	5/8 SAE PLAIN WASHER, OIL&PHOS	2
7	14950038	U-BOLT, M20 X 2.50, 79 X 315	4
8	1500-1182	BOX(10 X 3 X 20.5)	2
9	1500-1255	BOX(4.25 X 2.50 X 8.00)	1
10	1500-1278	BOX(22X3X49)	1
11	15000926	BUSHING-SWAY BAR, POLYURETHANE	2
12	15000927	BUSHING	8
13	15001816	BAG-PLASTIC,HEATSEALED (8.0 X 15.0)	1
14	80001950	SWAY BAR	1
15	80001951	LINK-CONNECTING	2
16	80001952	CLAMP-MOUNT, SWAY BAR	2
17	80001953	TUBE-BUSHING	4
18	800M1055	BRACKET-MOUNT, SWAY BAR	1
19	800M1056	BRACKET-MOUNT, SWAY BAR	1
20	810M0111	BRACKET-MOUNT, AIRSPRING, UPPER	1
21	810M0112	BRACKET-MOUNT, AIRSPRING, UPPER	1

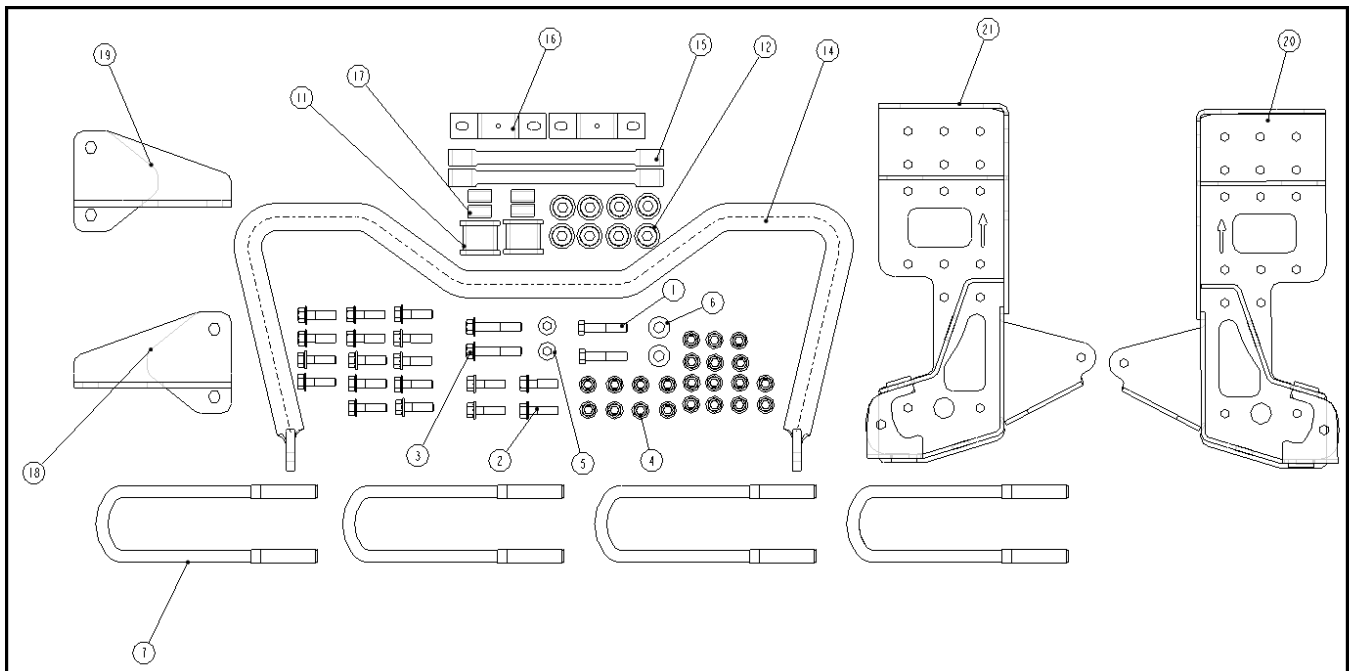

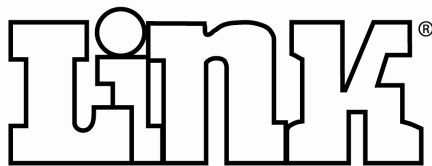

Link Mfg. Ltd.
223 15th St. NE
Sioux Center, IA USA
51250-2120

(712) 722-4874

<http://www.linkmfg.com/>