

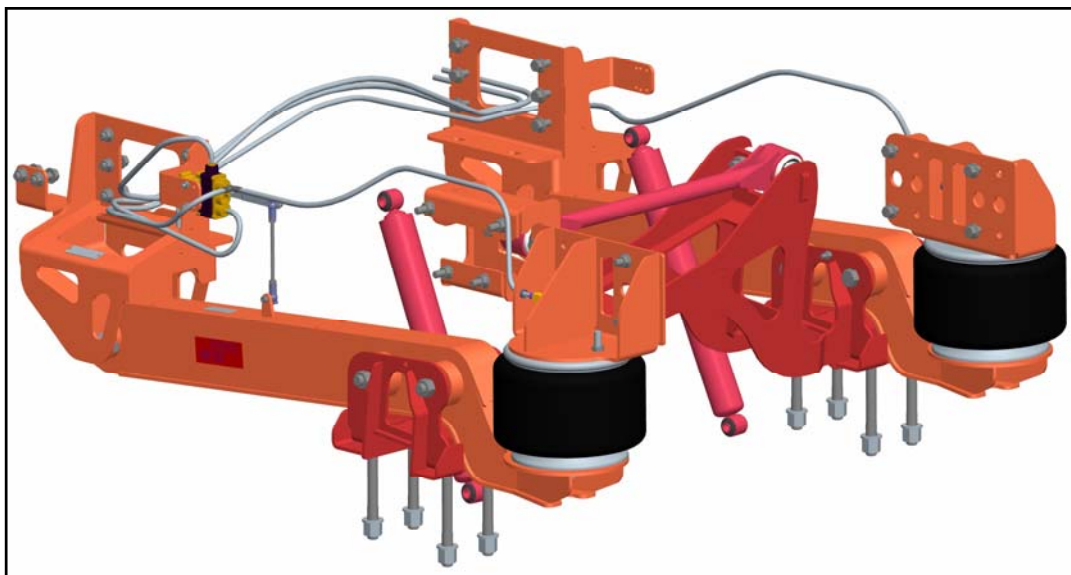

**LINK**  
**UltraRide**  
CHASSIS AIR SUSPENSION

# OWNERS MANUAL

GM C4500/C5500 4X4  
DANA MODEL S135 REAR AXLE  
2005-NEWER MODELS  
LINK MFG. PART NO. 8M000060



Link Mfg. Ltd.  
223 15th St. N.E.  
Sioux Center, IA USA  
51250-2120

(712) 722-4874  
Fax (712) 722-4876

**QUESTIONS?  
CALL CUSTOMER  
SERVICE  
1-800-222-6283**

**PROUDLY INSTALLED BY :**

**COMPANY :** \_\_\_\_\_

**INSTALLER SIGNATURE :** \_\_\_\_\_

**DATE :** \_\_\_\_\_

# INSTALLATION INSTRUCTIONS INDEX

- 1.0 INTRODUCTION
- 2.0 DRIVER SIDE DISASSEMBLY
- 3.0 PASSENGER SIDE DISASSEMBLY
- 4.0 LATERAL CONTROL ROD ASSEMBLY
- 5.0 DRIVER SIDE ASSEMBLY
- 6.0 PASSENGER SIDE ASSEMBLY
- 7.0 AIR CONTROL SYSTEM
- 8.0 ELECTRICAL
- 9.0 FINAL INSPECTION & OPERATION
- 10.0 SERVICE & MAINTENANCE

# 1. INTRODUCTION

**IMPORTANT!** It is important that the entire installation instructions be read thoroughly before proceeding with suspension installation.



**WARNING!** A correct installation must result in the suspension and axle being “loaded” within the range specified by axle and suspension manufacturers. Please check vehicle specifications and intended usage to insure axle will be within Gross Axle Weight Rating (GAWR). No alteration of any suspension component is permitted.

## **PRODUCT INSTALLER RESPONSIBILITIES**

- Installer is responsible for installing the product in accordance with Link Mfg. specifications and installation instructions.
- Installer is responsible for providing proper vehicle components and attachments as well as required or necessary clearance for suspension components, axles, wheels, tires, and other vehicle components to ensure a safe and sound installation and operation.
- Installer is responsible for advising the owner of proper use, service and maintenance required by the product and for supplying maintenance and other instruction as readily available from Link Mfg.

## **INSTALLATION NOTES:**

- Proper tightening of U-Bolt Nuts and Mounting Fasteners are required for proper operation. Need for proper Torque value is indicated by wrench symbol and values will be found in Table 10-1 in Maintenance section of the instructions. Failure to maintain proper torque can cause component failure resulting in accident with consequent injury. 
- No drilling of new frame holes is required for installation of the suspension, Mounting of the air control system will require some holes being drilled into the frame at the location of your choice.

**NOTE:** When completing the installation of the UltraRide on the GM chassis, please reference the appropriate sections GM Service Manual for additional requirements.

## PRE-INSTALLATION CHECKLIST

- ❑ Check the vehicle wheel alignment prior to installation to insure no precondition already exists; record the information for verification.
- ❑ Remove the attached body, if applicable. Remember to disconnect all electrical connections to the body, and fuel filler tube, before removing the body. The installation can also be completed using a lift to raise the vehicle. If using a lift, chassis body removal may not be necessary but removal of rear wheels will aid in installation. Refer to GM Document 812944 and 827666.
- ❑ If not using a lift, block the front wheels and apply the emergency brake so the vehicle cannot roll.
- ❑ Jack up the rear frame of the truck in order to unload the rear leaf springs (or use an overhead hoist). It may also be advantageous to place jack stands under the rear axle itself. This will take some of the weight off the axle, and help to keep it from moving during disassembly. The stands **should not** raise the tires off the ground.
- ❑ Install the suspension in the listed sequence. Install one side of the suspension at a time. First, install the driver side completely, then install the passenger side. Removal of the rear wheels, if using a lift, may aid in installation, but it is not necessary.
- ❑ Measure & record the wheelbase and centering dims before beginning installation.

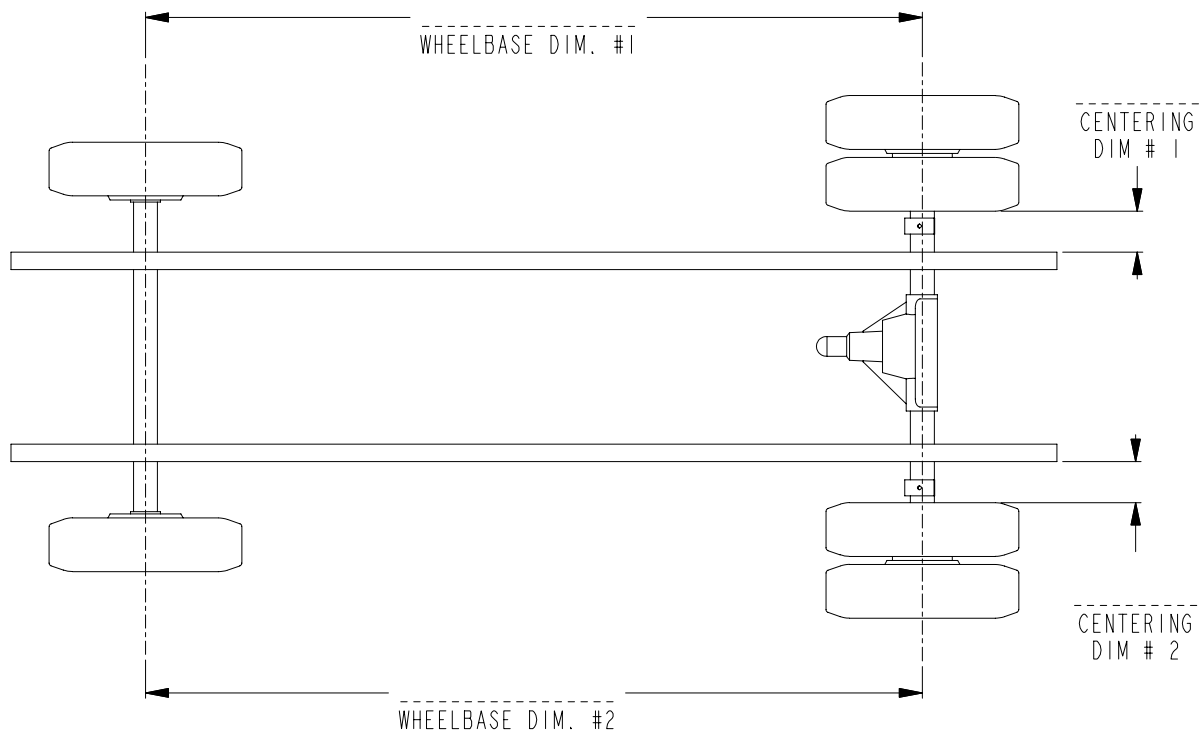

## 2. DRIVER SIDE DISASSEMBLY

1. With weight taken off the rear springs, as noted in pre-installation checklist, remove the rear bolts from the **rear leaf spring hanger bracket**. Remove the **front spring hanger bracket**. **DO NOT** re-use the fasteners that mount the hanger bracket, or the leaf spring itself. New fasteners are provided, and must be used to achieve proper clamp load on the hanger. See Figure 2-1. Refer to GM Documents 800862 and 1202795.
2. Remove existing U-bolts that attach the axle to the leaf spring. After this is done, axle, spring, and hanger will be loose. Remove only the leaf spring from the axle, **DO NOT** re-use existing fasteners such as the U-bolts or nuts. New fasteners are provided. **Rear leaf spring hanger bracket** can now be removed completely. Remove OE Cast Iron Spring Perch from axle, this will not be used in the assembly. See Figure 2-2, 2-3 for details.
3. Grind/remove 4 rivets that connect the aft of axle cross-member to the frame. This cross-member will be



**WARNING!** If truck has C5V042 option the fuel tank will not be in this location, but will be mounted further back on the truck. Use corresponding holes in upper air spring brackets to accommodate this.

located 9.72 inches aft of the axle centerline. (See Figure 2-2 for location of these rivets).

4. Remove the OEM shock absorbers and retain the mounting fasteners for later use.
5. Remove the OE jounce bumper bracket from the frame, on Driver side only. These Frame holes will be shared with Lateral Control Bracket, mounted to the inside of the frame.
6. Remove the OEM Stabilizer bar, as it will not be used with the new suspension.



## 3. PASSENGER SIDE DISASSEMBLY

1. Repeat Section 2 for the passenger's side of the truck. After disassembly of both sides, axle will be loose. Place stands under axle as noted in pre-installation checklist, to keep in place.

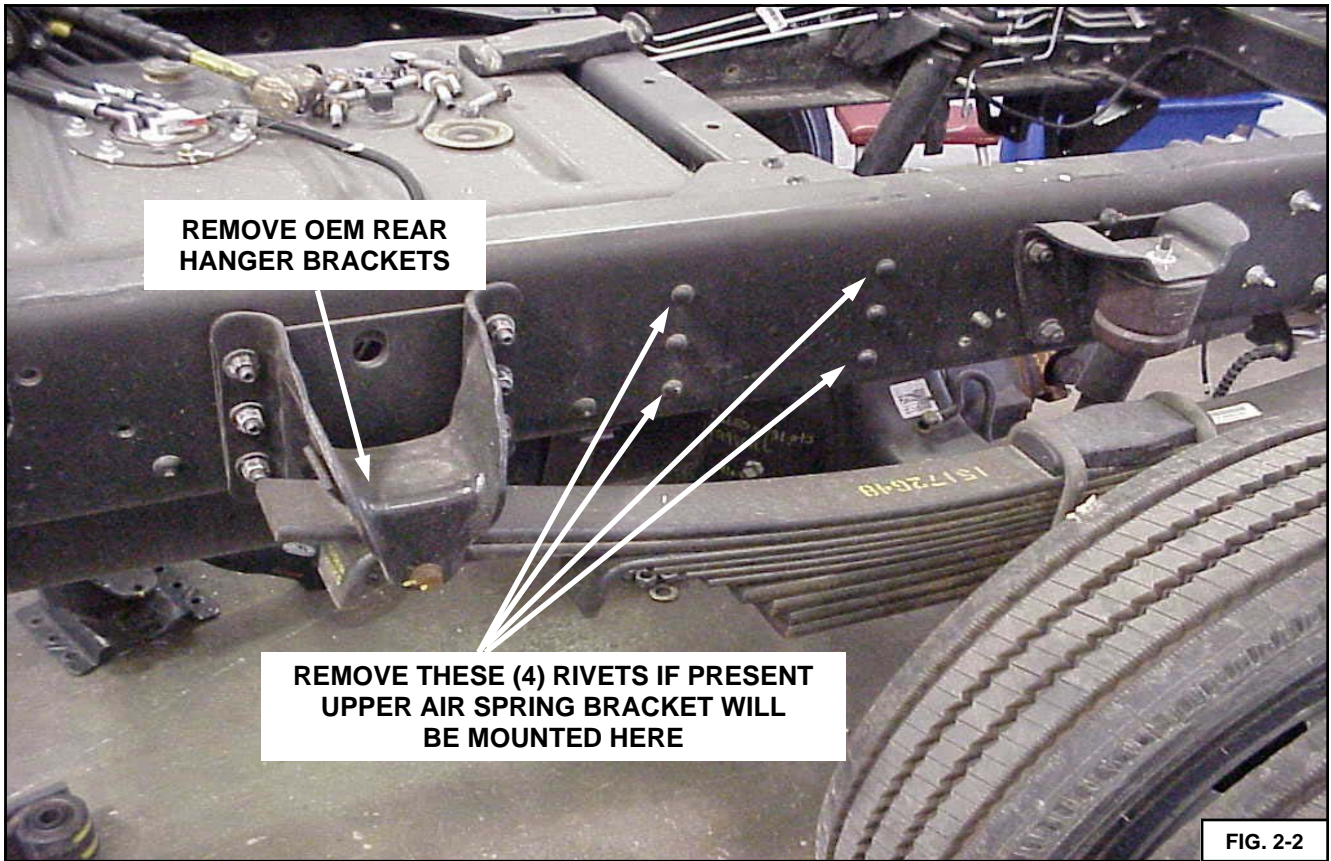





# 4. LATERAL CONTROL ROD

1. Review Figure 5-3 & Parts List/Drawing (Section 10) to acquaint yourself with the various parts of the UltraRide suspension.
-  2. Position AXLE MOUNTED LATERAL CONTROL ROD BRACKET onto axle as shown in Fig. 4-1. Mount Loosely to axle using (4) 3/4 UNF SQUARE BOLTS, (8) 3/4 SAE HARDENED WASHERS, and (8) 3/4 UNF HIGH NUTS. Parking brake cable will need to be remounted in the position shown in Fig. 4-1, and 5-3.
-  3. Place the frame mounted UPPER LATERAL CONTROL ROD BRACKET to the inside of the frame. Fasten this bracket to the frame using (4) 1/2 UNC TOP LOCK FLANGE NUTS, with bolts protruding through from the inside out. Place The OE Jounce Bumper back in place on the outside of the frame as it was. (See Table 10-1 for appropriate Torque).
4. Check to make sure that axle itself is centered between the frame rails, by measuring from the outside of the driver and passenger side frame rails to the inside of the wheel hub, or tire.
5. Tighten (8) 3/4 UNF HIGH NUTS that were assembled loosely in step 1. (See Table 10-1 for appropriate Torque).
6. Once both LATERAL CONTROL ROD BRACKETS are installed, loosely mount the LATERAL CONTROL ROD between the two sides using (4) 5/8 X UNF BOLTS and (4) 5/8 UNF TOP LOCK NUTS. See Figure 4-1 and 4-2 for details.
7. Tighten (4) 5/8 UNF TOP LOCK NUTS assembled loosely in step 4. (See Table 10-1 for appropriate Torque).

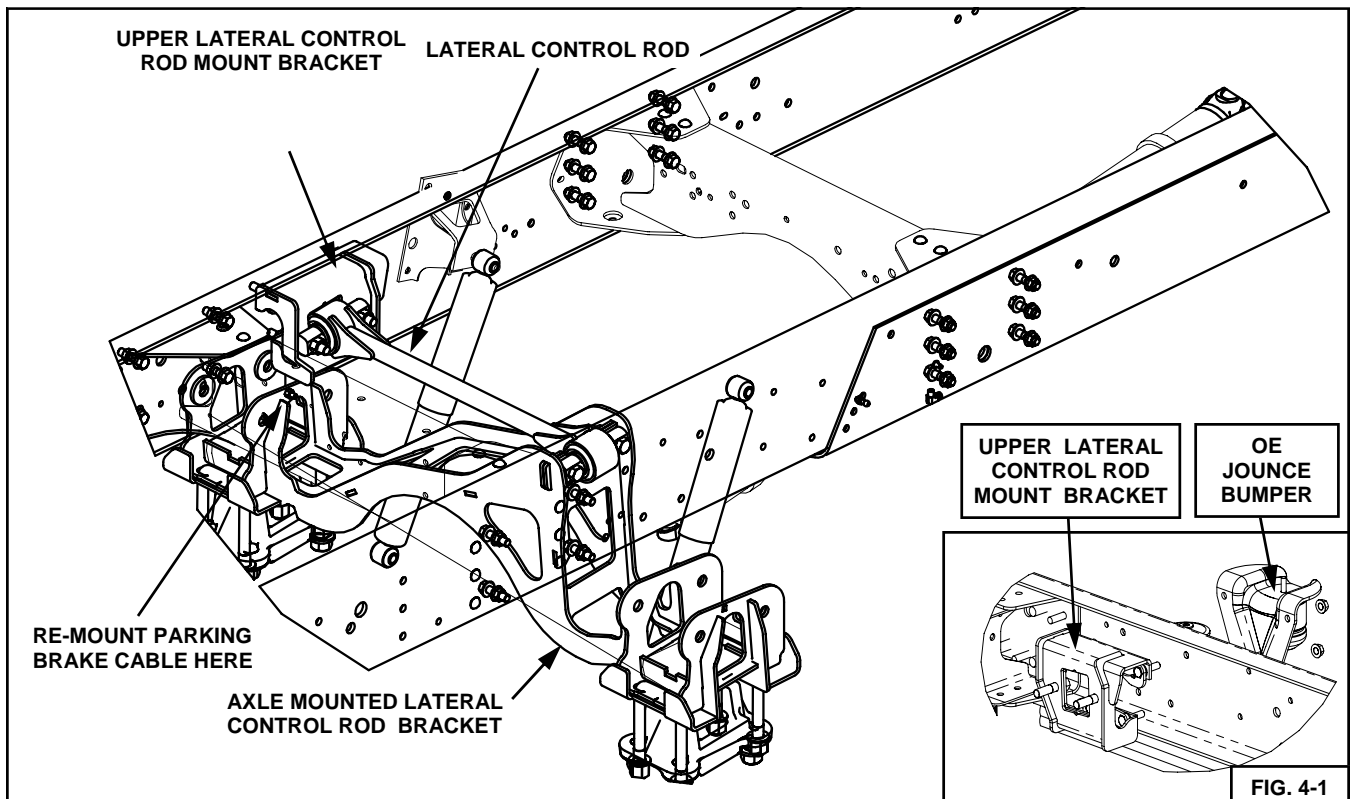
**NOTE:** Inspect Lateral Control Rod for any interference with other components, paying close attention to clearance with any flexible components such as brake and fuel lines.



# 5. DRIVER SIDE ASSEMBLY

 1. Unbolt Parking brake cable from driver's side of frame, and remount using the supplied PARKING BRAKE RELOCATION BRACKET. This will offset the cable under the frame to allow for clearance from the FRONT HANGER. See Fig. 5-1, 5-2, 5-5, 5-4 (See Table 10-1 for appropriate Torque).

 2. Fasten the FRONT HANGER to the frame using (6) 1/2 x 1 3/4 UNC FLANGE BOLTS and (6) 1/2 UNC TOP LOCK FLANGE NUTS, supplied with kit. See Fig. 5-1, 5-2. (See Table 10-1 for appropriate Torque).

3. Position the DRIVER SIDE TRAILING ARM on top of the LOWER LATERAL CONTROL BRACKET as shown in Fig. 5-3, 5-4. Be sure (2) PLASTIC SPACER TUBES As Shown in Fig. 5-4. Slide (2) 3/4 X 7 UNC FLANGE BOLTS into the (2) rear holes to hold the TRAILING ARM in place. See Fig. 5-3, 5-4 for details.

4. Secure The TRAILING ARM loosely to the FRONT HANGER with (2) 3/4 X 3 UNC FLANGE BOLTS AND (2) 3/4 UNC FLANGE NUTS. See Fig. 5-2, 5-4 for bolt orientation.

 5. Secure the TRAILING ARM to the LOWER LATERAL CONTROL BRACKET, using (2) 3/4 X 7 UNF BOLTS, AND (2) 3/4 UNF TOP LOCK NUTS. Tighten these 3/4 UNF fasteners at this time. (See Table 10-1 for appropriate Torque).

6. Fasten the UPPER AIR SPRING BRACKET , and AIR SPRING to the frame using (6) 1/2 X 1 3/4 UNC FLANGE BOLTS and (6) 1/2 UNC TOP LOCK FLANGE NUTS. Bracket will have (2) possible mounting locations, depending on cross-member/fuel tank location. Use the location shown by the 7.78 dimension shown in Fig. 5-5

7. Tighten the 3/4 UNC JAM NUT on the lower AIR SPRING STUD that goes through the TRAILING ARM. (See Table 10-1 for appropriate Torque).

8. Torque the (4) 3/4 X 3 UNC FRONT TRAILING ARM front pivot bolts. (See Table 10-1 for appropriate Torque).

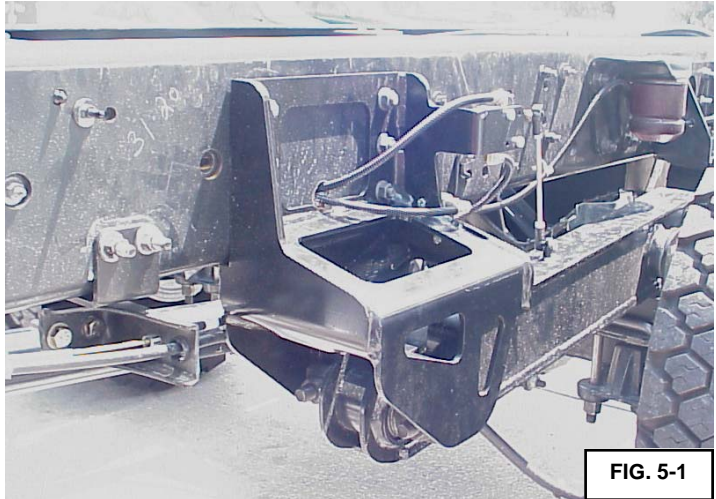

FIG. 5-1

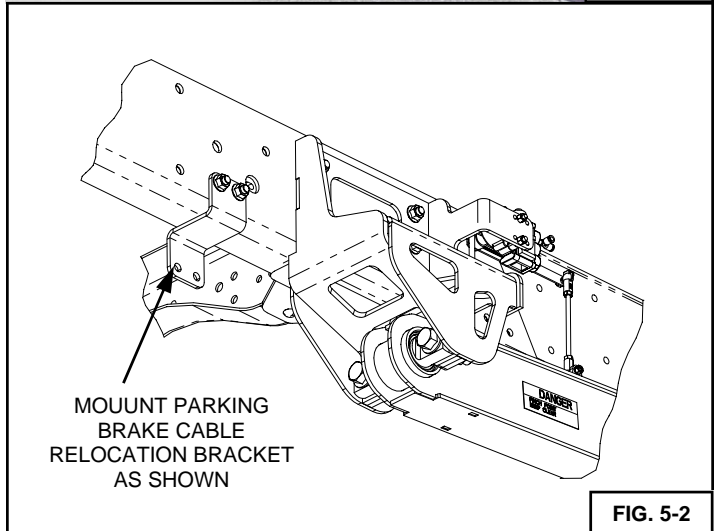

FIG. 5-2

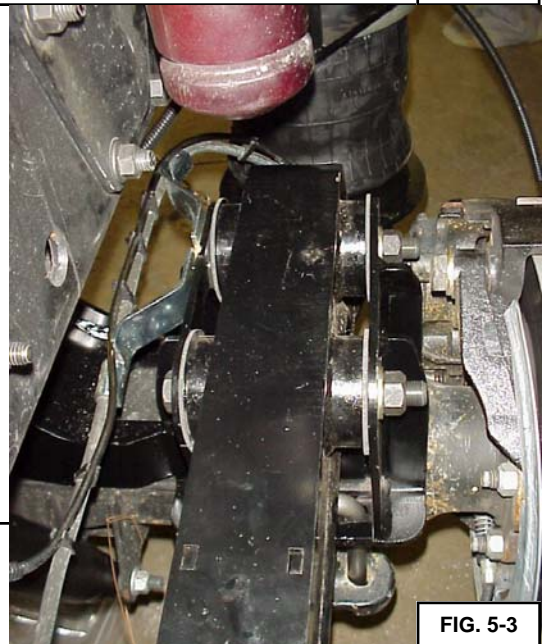
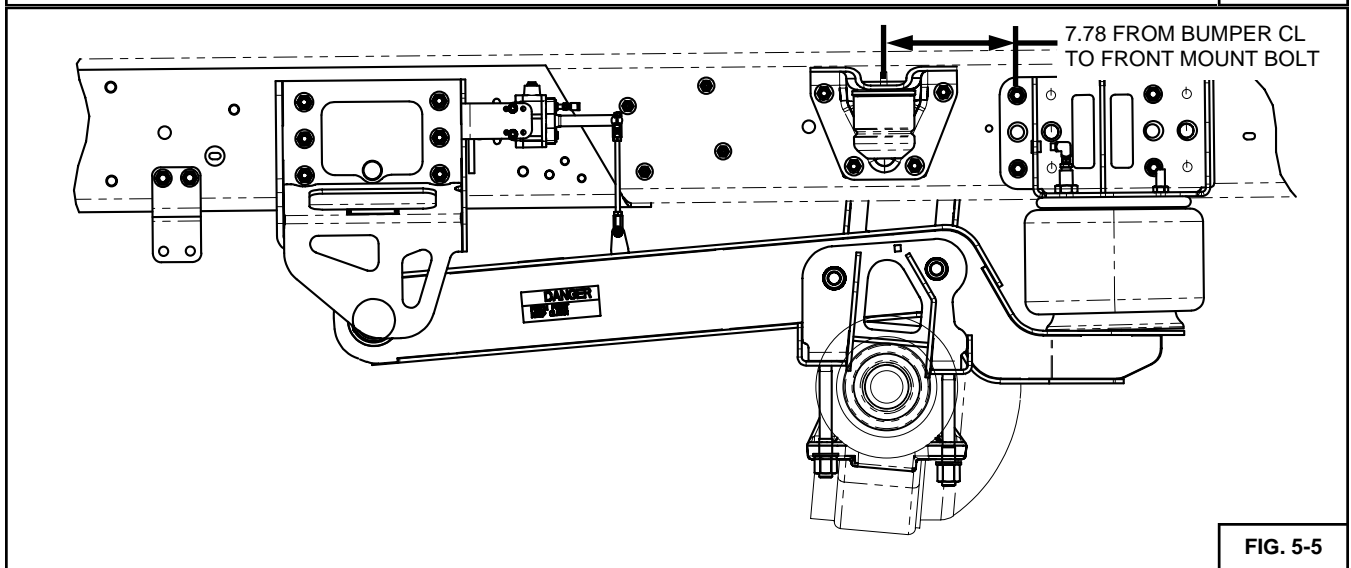
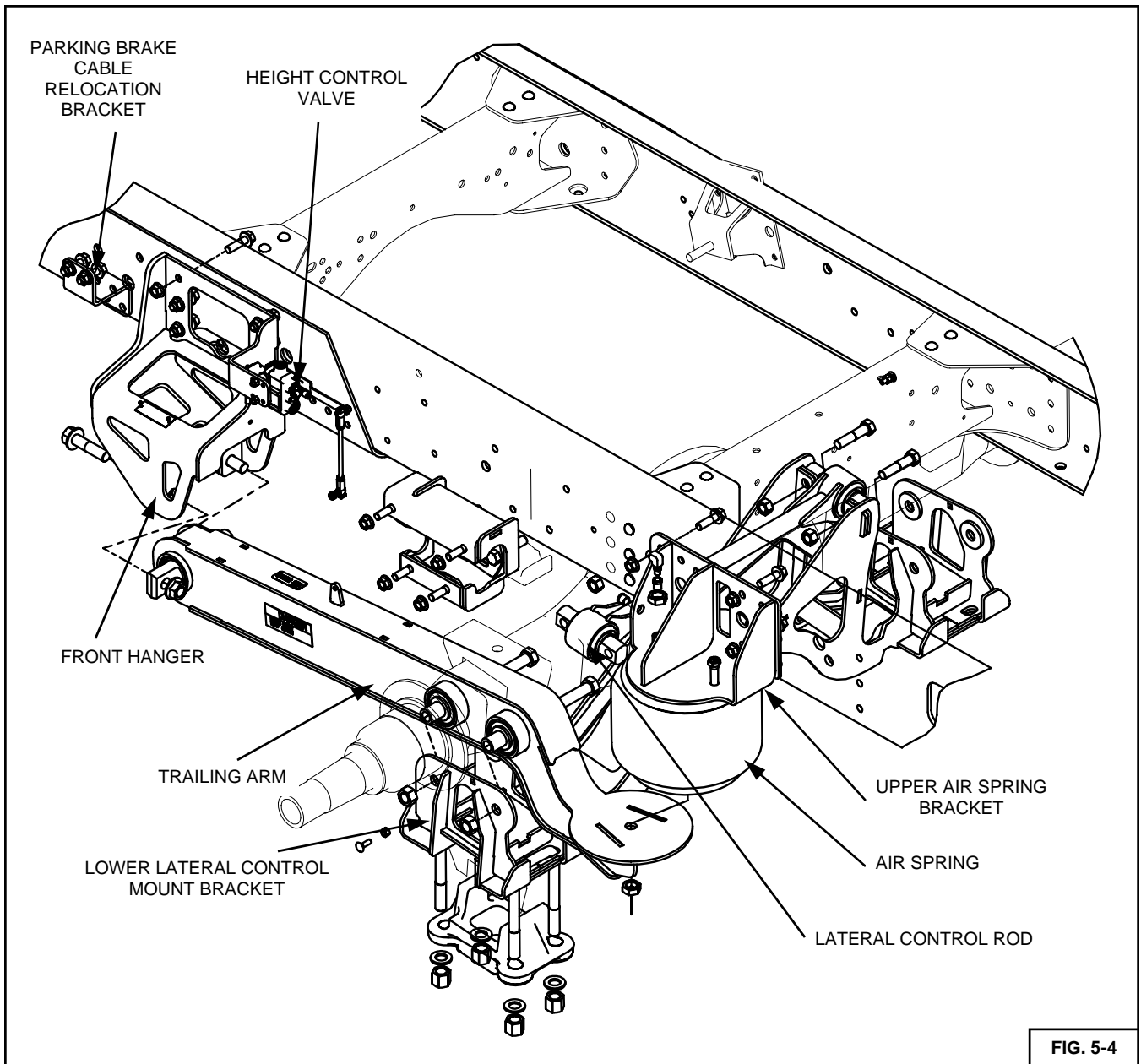

FIG. 5-3



**IMPORTANT: All frame mounted fasteners must be oriented pointing out, as shown.**





## 6. PASSENGER SIDE ASSEMBLY

1. Repeat Section 3 for the passenger's side of the truck.
2. Check all clearance points and all alignments. See Figure 5-1 for details.

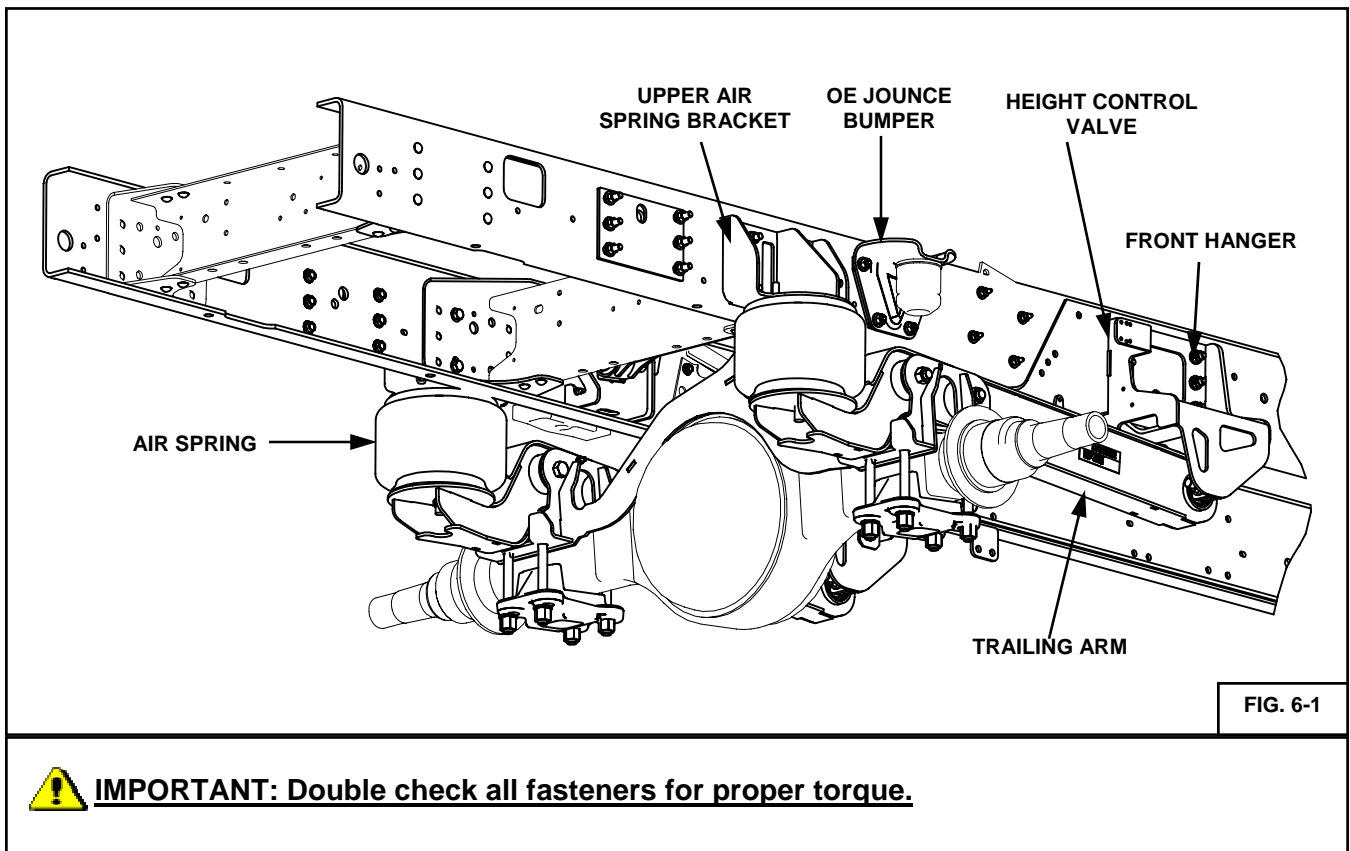

8. **AFTER BOTH SIDES HAVE BEEN INSTALLED (SECTIONS 3, 4, 5, 6) FINISH THE FOLLOWING STEPS:**
9. Install the new SHOCK ABSORBERS using the same orientation as factory using hardware provided.
10. **IMPORTANT: Route the all brake cables away from the air spring and other moving components.** A PARKING BRAKE CABLE RELOCATION BRACKET has been supplied with kit. This will allow it to clear the DRIVER'S SIDE FRONT HANGER BRACKET. Double check clearance with it, and all other components after complete assembly.

# 7. AIR CONTROL SYSTEM ASSEMBLY



**CAUTION!** Route all airline away from exhaust, moving parts, and sharp objects. Be careful not to crimp the edges of the tubing. When installing the airline, fully insert into fitting and give a slight pull to seat properly and to be sure airline will not pull out.

**Note:** If your vehicle has a frame body that does not allow the air control system box to be located as shown, you will need to determine another location for mounting and drill the necessary holes. If installing on the frame underneath the cab, make sure it is mounted as high on the frame as possible to allow for ground clearance below the tank.



1. Mount the Air Control Box to the side of the frame in the specified location. Use (4) 5/16 X 1 3/4 UNF FLANGE BOLTS and (4) 5/16 UNF TOPLOCK FLANGE NUTS to fasten the Air Control Box to the frame, placing the rubber isolators between the box and frame. Do not tighten the fasteners so tight that back of the Air Control Box contacts any bolts protruding from the frame. (See Table 10-1 for appropriate Torque).
2. Route the (6) airlines as shown in Figures 7-1, 7-2, & 7-3.
  - 2.1. Route AIRLINE 1 from the supply port of the Height Control Valve to the lower outlet port of the Air Reservoir Solenoid.
  - 2.2. Route AIRLINE 2 from the top Elbow in the Height Control Valve to the elbow in the Air Reservoir Solenoid.
  - 2.3. Route AIRLINE 3 & 4 from the Run Tee on del port of the Height Control Valve to the Air Springs.
3. Place supplied corrugated loom onto all airlines. Use supplied cable ties and airline clips to secure airline and to keep it away from all hazardous objects. See Figure 7-4 for details.

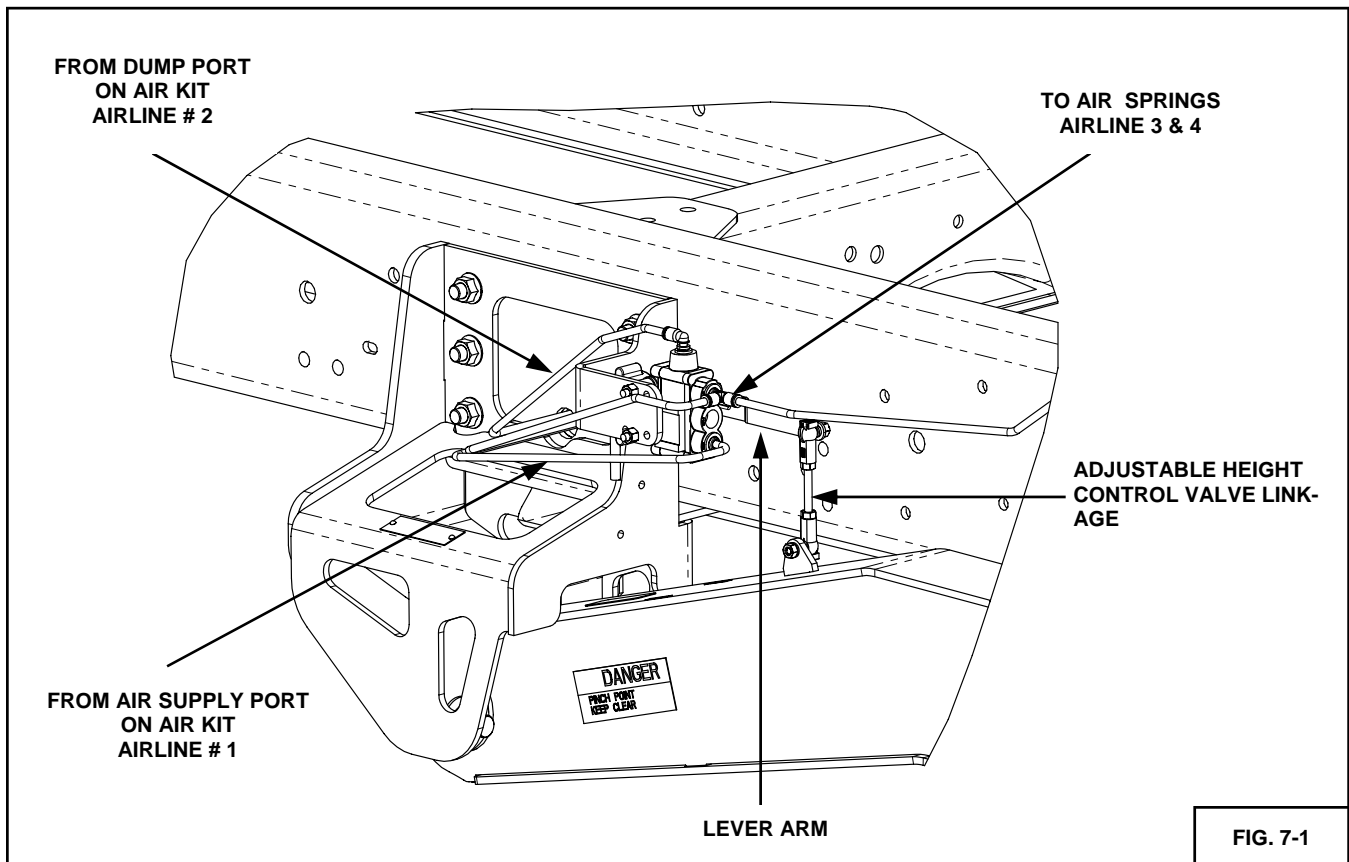

# AIR CONTROL KIT AIR CONTROL SCHEMATIC

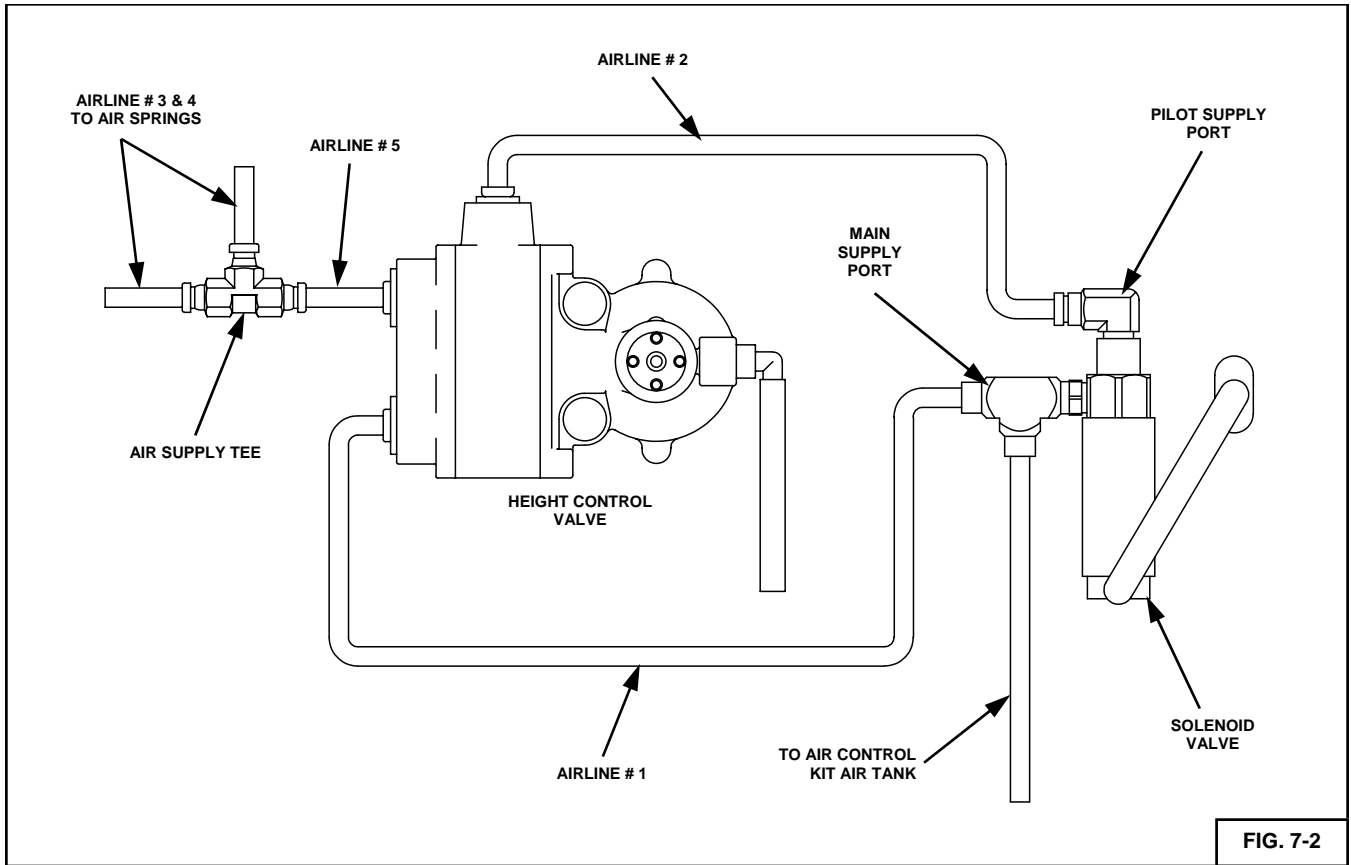

**FIG. 7-2**

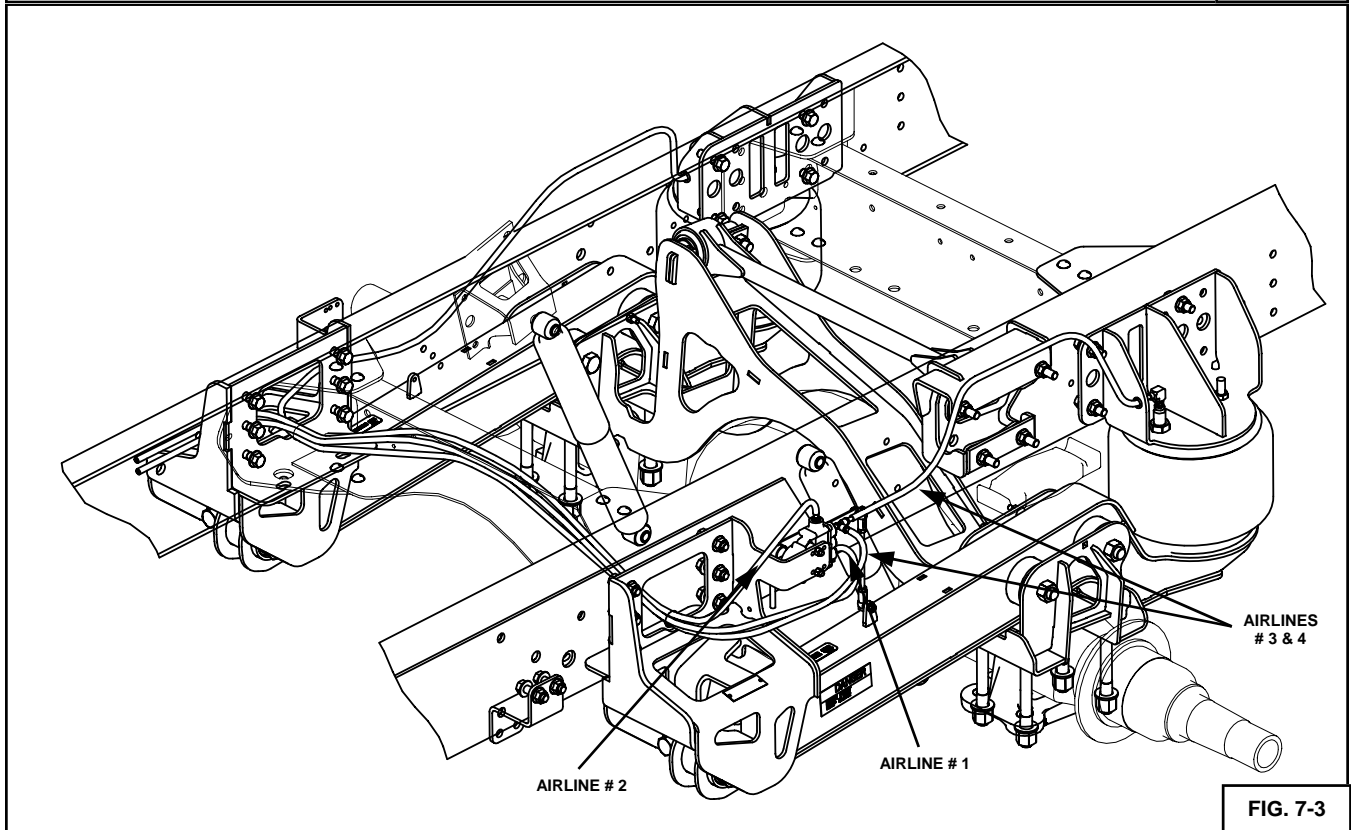

**FIG. 7-3**

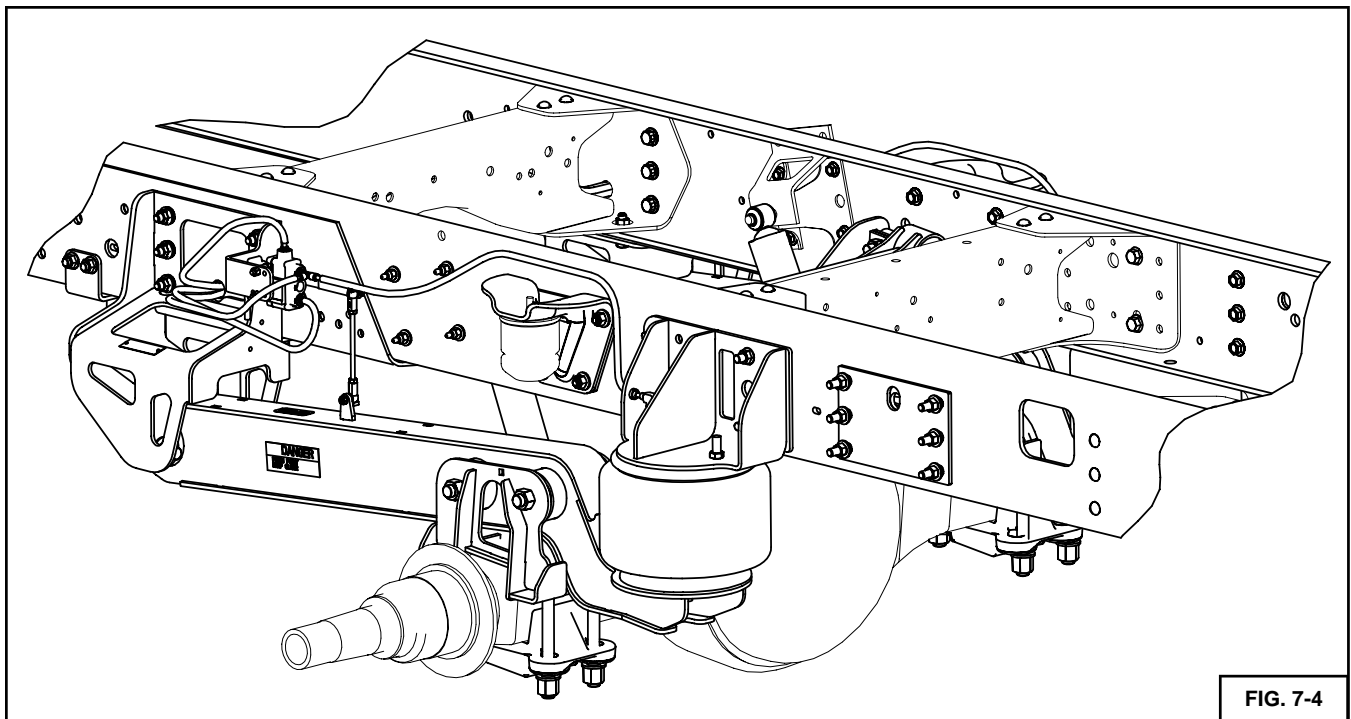

## 8. ELECTRICAL SYSTEM



**CAUTION!** All wiring should be routed and secured neatly to avoid any functional or visual issues. Under hood and under-body wire routings should be clear of sharp edges (3/4 inches minimum) and direct sources of heat (4 inches minimum). Wiring located in the passenger compartment should be routed away from high temperature areas over the muffler. Wiring should not be routed through wheel well areas where it may be damaged by tire or road debris, and it should not be routed over the exhaust system. Wiring should not contact the brake lines or fuel lines. Disconnect the battery cables before servicing any electrical components. See *GM Documents 173237 and 173165*. Refer to the *GMT560 Best Practices Manual* for more information on tying into electrical components.

1. Refer to **AIR CONTROL KIT OWNERS MANUAL** for further details on electrical system installation and parts list.

## 9. FINAL INSPECTION & OPERATION

1. Recheck all fasteners for specified torque.
2. Double check all electrical connections and wire routings.
3. Remove all jacks and air system up by either using the fill valve on the air tank or by starting the vehicle and switching the compressor switch to "ON". Note: the maximum allowable pressure in the air tank is 120 psi. It is recommended to fill the air tank using the supplied schraeder valve so that the compressors are not taxed too much by running for a long period of time.
4. Check for proper operation of the height control valves. With one end of the valve linkage disconnected rotate the valve arm down 45°, air should exhaust from the air springs. Rotating the valve arm up 45° should cause the valve to fill the air springs.
5. Measure the "Design Height" of the air springs. The height should be as shown in Figure 9-1, and **measured at the middle of the air spring**. To adjust the design height (see Figures 9-2, 9-3) disconnect one end of the valve linkage and adjust accordingly. Turn the plastic ball end joint to change the length of the linkage (increasing the length will increase the Design Height, and vice-versa). Tighten the lock nuts on the valve linkage when complete. See Figure 10-3. **Set the design height by the following sequence:** 1) deflate the passenger side air bag by disconnecting the linkage from the arm, 2) with the driver side linkage connected, measure the design height and adjust accordingly by the methods mentioned above, 3) once the design height is set for the driver side, repeat the same steps for the passenger side, including deflating the driver side air bag. Once the design height is set, reconnect the linkages. Jostle the suspension up and down and then allow it to come back to design height. Recheck the initial measurement and adjust if needed. **Note: this procedure to set design height can be done when empty or under light load.**
6. Move the suspension throughout its entire range of motion, by inflating and deflating the air springs to achieve full travel. Check for any interferences with the lateral control rod, axle, shocks, exhaust, frame, brake lines (**especially on the driver side**), fuel lines, etc. Reconnect the valve linkage to the lever. **Note: if contacting the brake lines, hand caulk the line to make clearance at least 1/4" between the brake line and the axle brackets.**
7. **IMPORTANT!** Check all fittings and airlines for air leaks.
8. Reinstall the chassis body (if applicable).
9. **IMPORTANT!** During servicing check tightness of all fasteners and for any air system leaks See Table 10-1 for torque specifications. Immediate corrective action should be taken if malfunctions occur.
10. After all final checks are complete, it is recommended to complete a full four- wheel alignment and drive line angle check. The pages following the installation instructions describe the proper method for checking driveline angles. Note: improper driveline angles may have a detrimental effect on ride, u-joints, and transmission. If any driveline vibration (or out of spec. angle measurement) occurs, use factory axle seat shims to modify driveline angle.
11. Kneeling Operation: Moving the switch "ON" to Dump will exhaust all air from the air springs and lower the rear of the vehicle approximately 3-4 inches. Air springs will inflate when the switch is returned to the "OFF" position. **WARNING: Do not drive the vehicle while the Dump Switch is on and the air springs are deflated.**

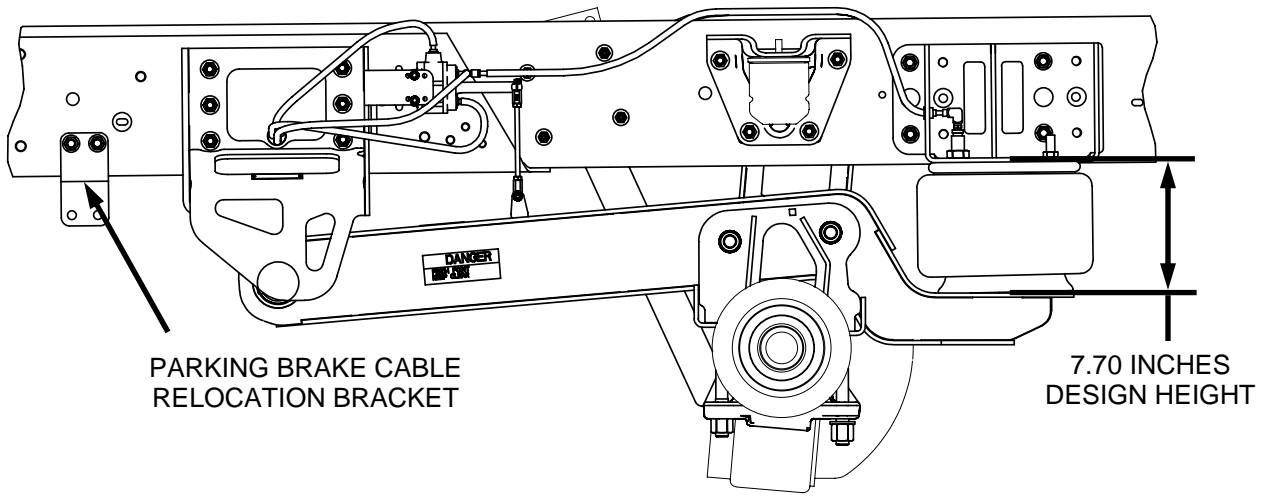
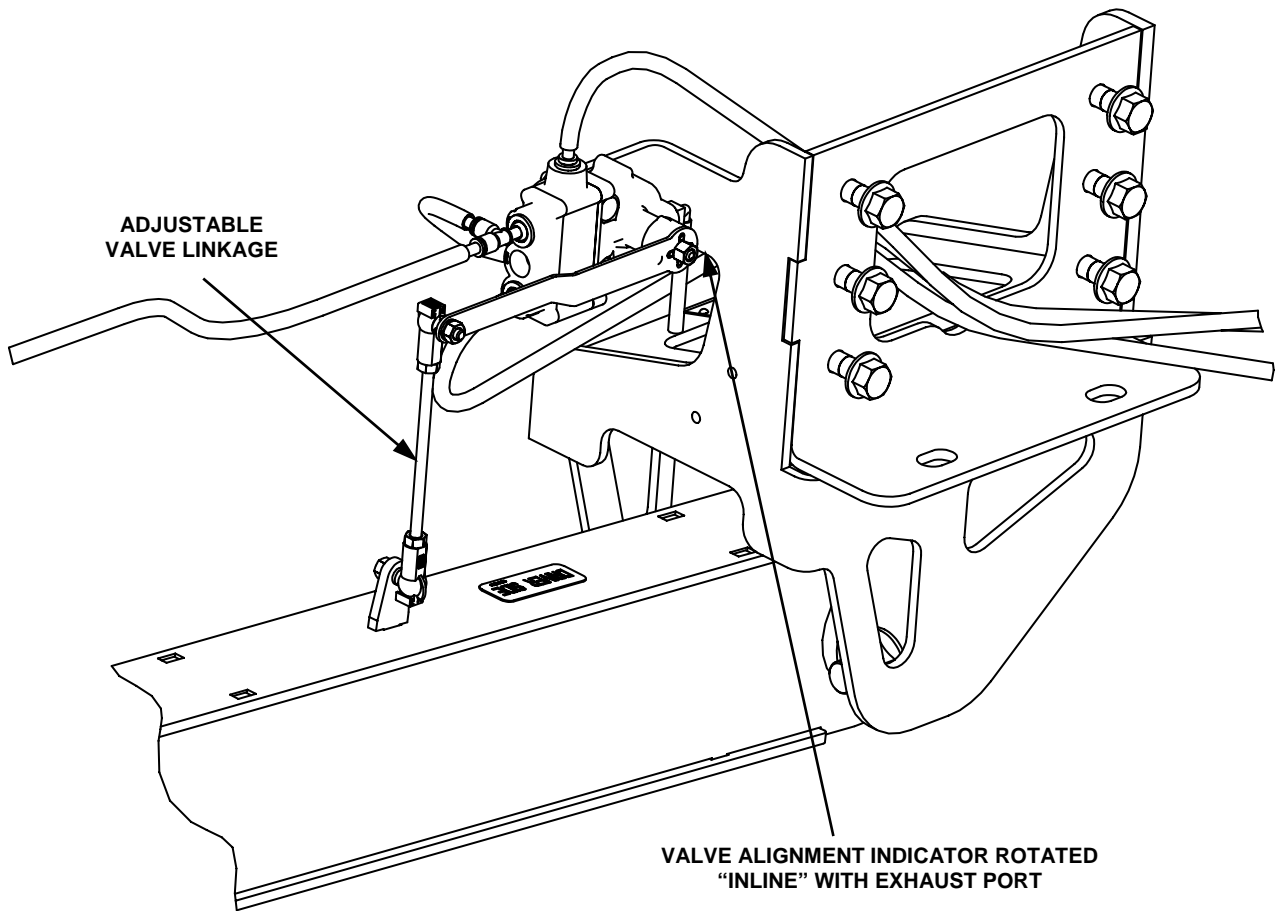

FIG. 9-1



DRIVER SIDE

FIG. 9-2

# 10. SERVICE & MAINTENANCE

The UltraRide suspension needs no lubrication and little maintenance. The following components should be checked at the time the truck is being serviced. However, immediate corrective action should be taken if a serious malfunction occurs. See Exploded Assembly on following page for details.

**Note:** It is important to release any moisture contained within the air reservoir on a daily basis. This can be done by pulling on the cable attached to the drain valve. See Figure 7-4. Not releasing the moisture on a regular basis will cause the drain valve to not operate properly, and may cause the valve to malfunction. Excess moisture in the system can also cause premature failure of other components including the tank itself.



**CAUTION!** If maintenance or service is to be done on the air system, be sure to drain **all** air from system. Serious injury could occur if components are removed while system is full of air.

## **INSTALLATION & MAINTENANCE CHECK LIST**

- Check and document OE rear axle alignment
- Set Design Height to 7.7 inches
- Verify suspension function via dump and re-inflation
- Check for air leaks and system integrity
- Check clearances throughout suspension motion range
- Check driveline angle
- 4 wheel alignment
- After installation measure and record wheelbase and centering dimensions  
See Fig. 10-2 on following page





TORQUE TABLE (Table 10-1)		
LOCATION	FASTENER	TORQUE
FRAME MOUNTED FRONT HANGER	1/2 UNC NUTS	90-120 FT-LBS
FRAME MOUNTED UPPER AIR SPRING BRACKET	1/2 UNC NUTS	90-120 FT-LBS
FRAME MOUNTED LATERAL CONTROL ROD BRACKET	1/2 UNC NUTS	90-120 FT-LBS
AXLE MOUNTED LATERAL CONTROL ROD BRACKET	HIGH NUTS FOR 3/4 UNF U-BOLTS	170-200 FT-LBS
LATERAL CONTROL ROD	5/8 UNF NUTS	180-240 FT-LBS
AIR SPRING STUD	3/4 UNC JAM NUTS	40-50 FT-LBS
TRAILING ARM - AXLE LOCATION	3/4 UNF NUTS	250-325 FT-LBS
FRONT TRAILING ARM PIVOT BOLTS	3/4 UNC NUTS	315-420 FT-LBS
AIR CONTROL BOX	5/16 UNF NUTS	15-20 FT-LBS

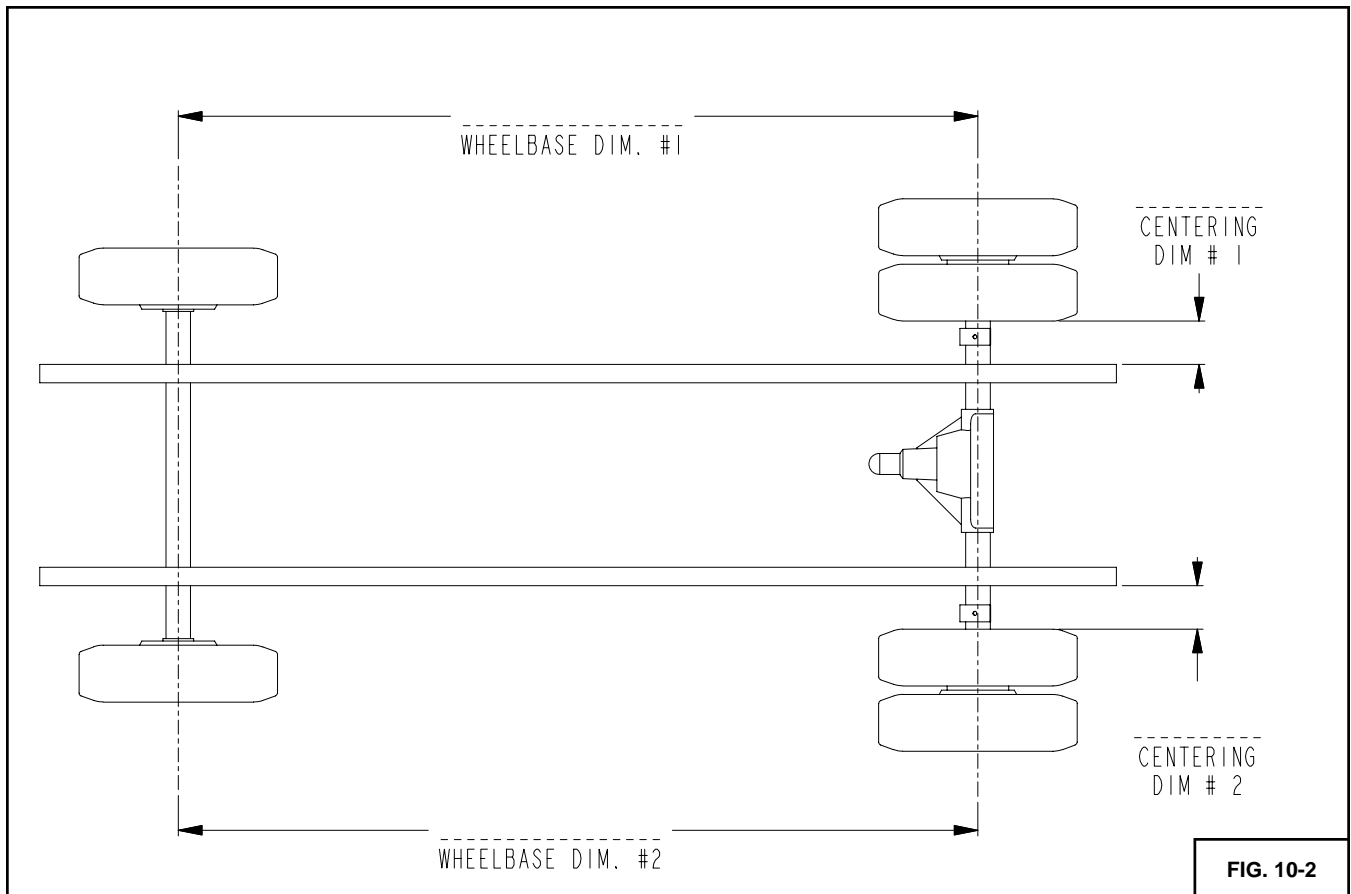

**FIG. 10-2**

# ***UltraRide* – GMC 4500/5500 4X4**

## **PARTS LIST**

ITEM	PART NUMBER	DESCRIPTION	QTY
1	1103-0502	SPRING-AIR	2
2	1210-0513	SHOCK ABSORBER	2
3	13010062	VALVE-CONTROL, HEIGHT	1
4	1302-2014	REDUCER, 1/8 F-NPT 1/4 M-NPT	2
5	1302-5090	ELBOW, 1/4 TB 1/8 M-NPT, PUSH-IN DOT	2
6	1302-5497	RUN TEE, 1/4 TB 1/4 PTC, PUSH-IN DOT	1
7	140D-2022	5/8 X 2 3/4 UNF HEX CAP SCR (GR 8) O&P	4
8	140D-2456	3/4 X 7 UNF HEX CAP SCR (GR 8) O&P	4
9	1411-1614	1/2 X 1 3/4 UNC FLANGE BOLT (GRADE 8)	22
10	141A-2424	3/4 X 3 UNC FLANGE BOLT (GR 8) O&P	4
11	1435-1008	5/16 X 1 UNC RND HD SQ NK BOLT (GRADE 5)	2
12	1470-0800	1/4 UNC HEX NUT (GR B)	2
13	1474-1600	1/2 UNC HEX JAM NUT	2
14	1474-2404	3/4 UNC HEX JAM NUT, O&P	2
15	1475-2402	3/4 UNF HEX JAM NUT, O&P	2
16	1477-2006	5/8 UNF HEX TOP LOCK NUT (GR C) O&P	4
17	1477-2406	3/4 UNF HEX TOP LOCK NUT (GR C) O&P	4
18	1478-1000	5/16 UNC HEX NYLOCK NUT (GR B)	2
19	1480-1604	1/2 UNC TOP LOCK FL NUT (GR G) O&P	26
20	1480-2404	3/4 UNC TOP LOCK FL NUT (GR G) O&P	4
21	1485-0800	1/4 LOCK WASHER	2
22	1488-2402	3/4 SAE HARDENED WASHER	8
23	1495-0035	U-BOLT, 3/4-16 UNF, 3.90 X 7.00	4
24	1500-0224	BALL-PIVOT, THREADED	2
25	1500-0266	LINKAGE-VALVE, HEIGHT CONTROL (6.50)	1
26	1500-0303	SNAP BUSHING (.250 MATL)	2
NS	1505-0023	HARNES-WIRE, PIG-TAIL	1
27	1506-0002	3/4 UNF HEX HIGH NUT	8
28	80000135	SPACER-TUBE	4
29	800M0096	LATERAL CONTROL ROD	1
30	800M0097	BRACKET-MOUNT, LCR, UPPER	1
31	800M0098	BRACKET-MOUNT, LCR, LOWER	1
32	800M0101	BRACKT-MOUNT, AIRSPRING, UPPER	1
33	800M0102	BRACKET-MOUNT, AIRSPRING, UPPER	1
34	810M0025	HANGER	1
35	810M0026	HANGER	1
36	810M0043	BRACKET-RELOCATION, BRAKE CABLE	1
37	820M0019	ARM	2

# UltraRide – GMC 4500/5500 4X4

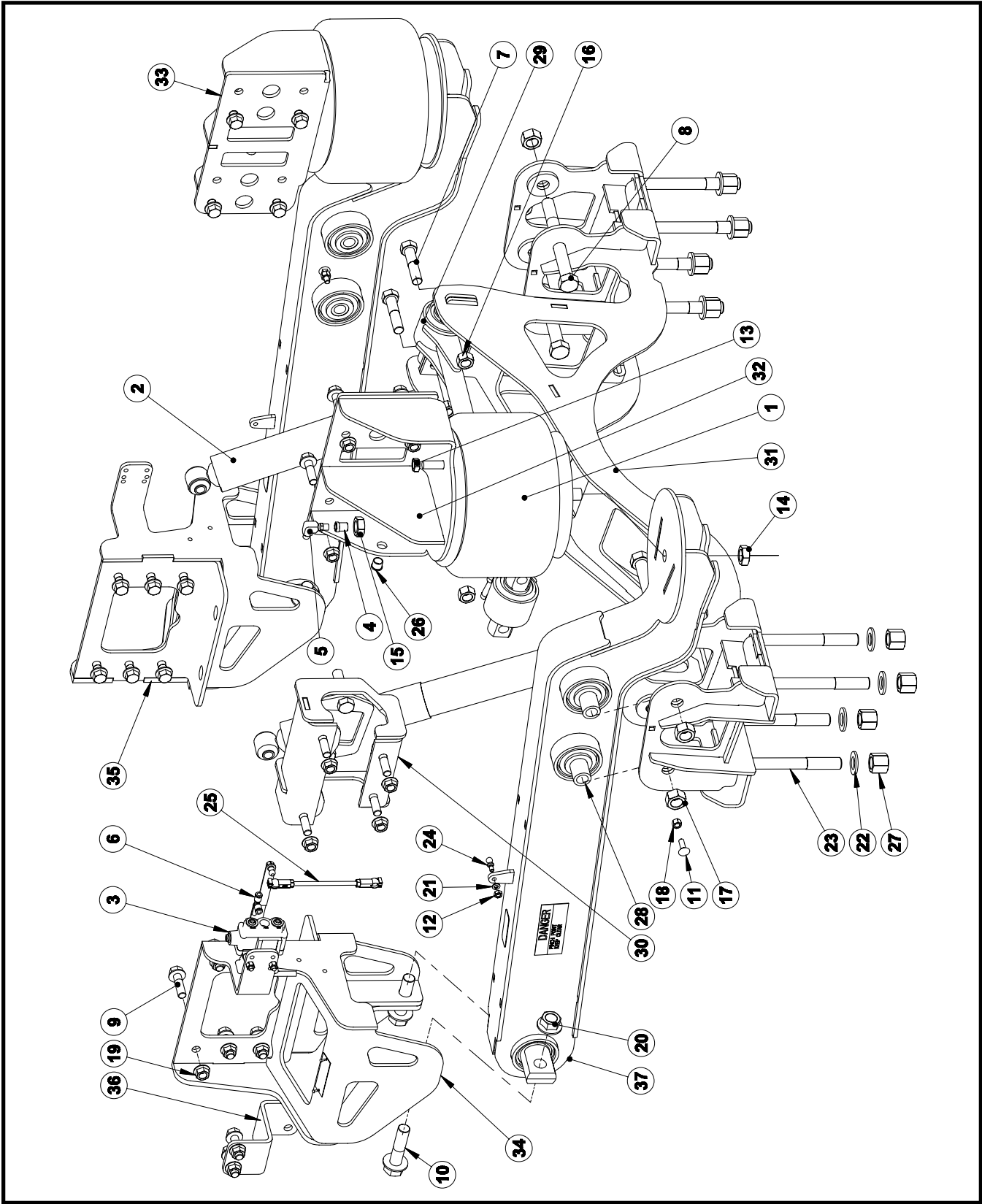

# ***UltraRide* - TROUBLE SHOOTING GUIDE**

<b>COMPONENT</b>	<b>POSSIBLE PROBLEM</b>	<b>CORRECTIVE ACTION</b>
<b>Airlines</b>	Air leaks	Replace airline
<b>Fittings</b>	Air leaks	Remove fitting and apply fresh joint compound. Reinstall fitting, but <b>Do Not Over tighten. Do not use Teflon tape.</b>
<b>Air Springs</b>	<b>A.</b> Improper height <b>B.</b> Air leakage	<b>A.</b> Adjust valve linkage to maintain proper air spring height. <b>B.</b> Replace air spring.
<b>Height Control Valve</b>	Air spring(s) will not inflate when weight is added to the chassis.  <p style="text-align: center;"><b>OR</b></p> Air spring(s) will not deflate when weight is removed from the chassis.	<b>A.</b> Inspect valves to insure drive bearing notch is located correctly. The driver side valve notch on <b>"SUPPLY"</b> port side of valve, passenger side on <b>"SUSP"</b> port side. If not, loosen lever screw (but do not remove completely) and pull lever loose from drive bearing, rotate drive bearing until the drive bearing notch is in the correct position and re-secure lever by tightening lever screw.  <b>See Fig. 11-3 &amp; 11-4 for orientation details</b> <b>B.</b> Replace valve.
<b>Shock Absorber</b>	Insufficient damping effect	Replace shocks
<b>Lateral Control Rod</b>	<b>A.</b> Loose nuts on lateral control rod bolts <b>B.</b> Worn bushings	<b>A.</b> Tighten securely. <b>B.</b> Replace lateral control rod.

# GMC C4500/C5500 4X4 ULTRARIDE

## OWNERS GUIDELINES

The UltraRide suspension needs no lubrication and little maintenance. However, immediate corrective action should be taken if a serious malfunction occurs.



**CAUTION!** If maintenance or service is to be done on the air system, be sure to drain all air from the system. Serious injury could occur if components are removed while system is full of air.

### **PRODUCT OWNER RESPONSIBILITIES**

- ❑ Owner is solely responsible for pre-operation inspection, periodic inspections, maintenance, and use of the product as specified in the particular LINK MFG. instructions available by product model, except as provided in this warranty, and for maintenance of other vehicle components. Of particular importance is the re-torque of fasteners including axle u-bolts, torque rod bolts and track rod bolts. This re-torque must be performed within 90 days of the suspension being put in service.
- ❑ Owner is responsible for “down time” expenses, cargo damage, and all business costs and losses resulting from a warrantable failure.
- ❑ The UltraRide Chassis Air Suspension is fully automatic in controlling the height of the chassis. No manual intervention to control air pressure or ride height is needed during the course of operation.
- ❑ The Compressor Switch must be on for the compressors to operate. During difficult starting circumstances, (i.e. extremely cold weather) it is recommended to turn the compressor switch off until the vehicle is running, so it will not draw current from the battery. The compressors are controlled by the pressure switch located in the Air Control Box. This switch automatically turns the compressors on when the tank pressure falls below 100 psi, and turns them off at 120 psi.
- ❑ The Low Pressure Warning Light indicates a severe drop in tank pressure (below 60 psi). Immediate corrective action should be taken to determine the cause of air loss. Compressor switch should be turned off if Low Pressure Warning Light is on, and remains on even after the compressors have run for a normal period of time. **NOTE:** The Low Pressure Warning Light could come on briefly when the “Dump” feature is being used.
- ❑ It is important to release any moisture contained within the air tank on a daily basis. This is done by pulling on the attached release cable for approximately 5 seconds. See Air Control Kit Owners Manual for location of this cable. Not releasing the moisture on a regular basis will cause the drain valve to not operate properly.

### **CHECK AT EVERY VEHICLE SERVICE INTERVAL:**

- ❑ Check Design Height  $\pm\frac{1}{4}$ ”.
- ❑ Check for air leaks around fittings.

### **CHECK AFTER THE FIRST 1000 MILES:**

- ❑ Recheck & tighten any loose fasteners.
- ❑ Check for any loose or worn components.

### **CHECK AFTER EVERY 30,000 MILES:**

- ❑ Check arm pivot bushings and lateral control rod bushings for wear; replace if worn

## Guideline - Driveline Angles

After vehicle build is complete, the driveline angles must meet the following "rules", both at unloaded, and fully-loaded, vehicle attitudes.

Rule #1: The NET OPERATING ANGLE, at any individual joint, must be at least 1/2 degree, and not to exceed 3 degrees. The net operating angle at any individual joint on an F Super Duty (F250, F350, F450, or F550) must not exceed 4 degrees. The preferred maximum angle is 2 degrees.

The NET OPERATING ANGLE (e) at any one joint is the combination of the joint angles in both the side view and the plan (top) view. This NET OPERATING ANGLE (e) equals:

By example, using Figure 1:  
The NET OPERATING ANGLE at JOINT - A = (ea) =

$$\sqrt{\left[ \text{Plan View Angle} \right]^2 + \left[ \text{Side View Angle} \right]^2}$$

$$\sqrt{(0)^2 + (\text{angle} - a)^2} \quad \begin{matrix} \geq 0.5^\circ \\ \leq 3.0^\circ \text{ or } \leq 4.0^\circ \end{matrix}$$

The NET OPERATING ANGLE at JOINT - B = (eb) =

$$\sqrt{(\text{angle} - x)^2 + (\text{angle} - b)^2} \quad \begin{matrix} \geq 0.5^\circ \\ \leq 3.0^\circ \text{ or } \leq 4.0^\circ \end{matrix}$$

The NET OPERATING ANGLE at JOINT - C = (ec) =

$$\sqrt{(\text{angle} - x)^2 + (\text{angle} - c)^2} \quad \begin{matrix} \geq 0.5^\circ \\ \leq 3.0^\circ \text{ or } \leq 4.0^\circ \end{matrix}$$

**Fig. 1**

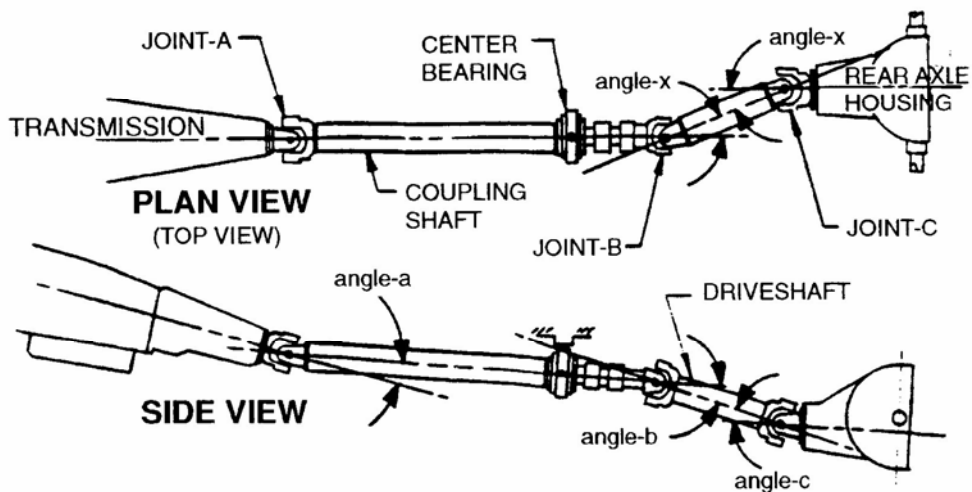

Guideline - Driveline Angles (Continued)

Rule #2: The combination of NET OPERATING ANGLES, throughout the whole driveline, **must** "cancel". It is preferred that the NET OPERATING ANGLES at either end of a shaft be within 1 degree of each other. However, at a minimum, the following formulas must be satisfied for sufficient "cancellation" to occur:

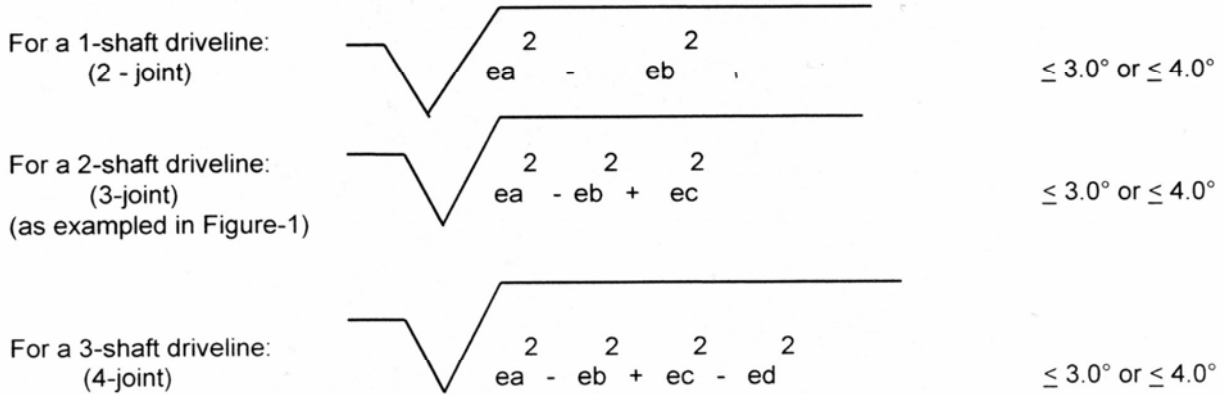

Rule #3: The center bearing mounting bracket, surrounding the rubber insulator, must be **90 ± 3 degrees** to the center bearing. In other words, no more than 3 degrees of mis-alignment can be absorbed by the rubber surrounding the center bearing. See Figure 2.

**Fig. 2**

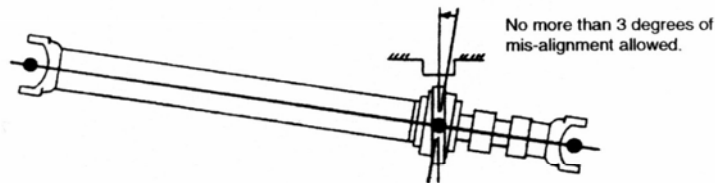

- A. Ensure that u-joints are in-line to within ± 2 degrees.
- B. Ensure matching alignment arrows between slip yoke and tube shaft

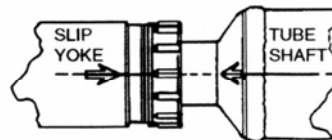
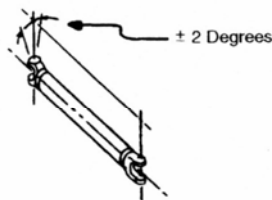

Observe alignment arrows stamped on parts. If there are no alignments marks, then add them before disassembly to ensure proper phasing alignment of shaft and yoke.

**GUIDELINE - DRIVELINE COMPONENT PHASING**

### **MINIMUM UNIVERSAL JOINT OPERATING ANGLE:**

A slight angle is required to prevent universal joints from brinelling. Therefore, a minimum operating angle of ½ degree is required.

### **MAXIMUM UNIVERSAL JOINT OPERATING ANGLE:**

Universal joint operating angles can be quite high, sometimes as high as 12 degrees. But to get a vehicle to operate successfully above 3 degrees often requires larger universal joints, double cardan or constant velocity joints, or restrictions on operating speed. A reduction in universal joint life becomes noticeable when they are operated at more than 3 degrees if precautions are not taken. That having been stated, the F Super Duty series of trucks (F250, F350, F450, and F550) can tolerate angles up to 4 degrees. However, maximum angles of 2 degrees are preferable for all vehicles.

Two shafts connected with a single cardan joint and turning at a constant speed with no joint angle, have no angular acceleration that could cause a vibration. When there is an angle between them and the input shaft is turning at a constant speed, the driven shaft is forced to continuously accelerate and decelerate, twice per revolution, creating a vibration. If the speed changes are small, the vibration is not objectionable. The guidelines in this appendix limit driveline angular acceleration to a maximum of 400 radians per second per second. This is the requirement for all Ford light trucks. (SAE specifies 500.) Some modified drivelines have been measured at over 11,000 radians per second per second causing driveline failures at very low mileage.

### **DRIVELINE ANGLE MEASUREMENT:**

Driveline angle measurements should be made with the vehicle supported by the tires and resting on a level surface. Avoid hoisting a vehicle by the frame since this will distort the chassis enough to make any measurements inaccurate.

### **MATCH MOUNTING DRIVESHAFTS TO THE REAR AXLE:**

Runout is measured on OEM rear axle input shafts and the maximum measurement is marked with a yellow dot on the yoke or pilot bearing flange. The OEM driveshafts are also marked with a yellow dot on the "light" side. When the parts are assembled, the marks are aligned to aid the overall system balance. Vehicle modifiers should look for these dots and maintain this match when the drivetrain is reassembled after modification. Remanufactured or modified driveshafts should also have their "light" sides matched to the yellow dot.

### **DRIVELINE VIBRATION DAMPERS:**

Driveline vibration dampers are sometimes added to driveshafts or axles to reduce noise, vibration, and harshness (NVH). If the chassis has these devices when it is received, they should be retained on the modified chassis.

### **USE OF DOUBLE CARDAN UNIVERSAL JOINTS FOR GREATER DRIVE ANGLES:**

In general, the use of these joints can allow increased drive angles up to as much as 8 degrees. However, when used at the rear of a coupling shaft a double cardan universal joint will prevent cancellation from occurring at the forward end of the shaft. Therefore the single cardan joint must still be maintained at less than 3 degrees (or 4 degrees for the F Super Duty series).

### **GENERAL COMMENTS:**

It is good practice, for any chassis that will have a driveline modification, to measure and record the driveline angles in each of the following conditions for later comparison.

- a. The chassis as first received from Ford (note that the drive angles may not conform exactly to this bulletin in this incomplete condition).
- b. The completed vehicle, unloaded.
- c. The completed vehicle loaded to GVWR with maximum front GAWR.
- d. The completed vehicle loaded to GVWR with maximum rear GAWR.