

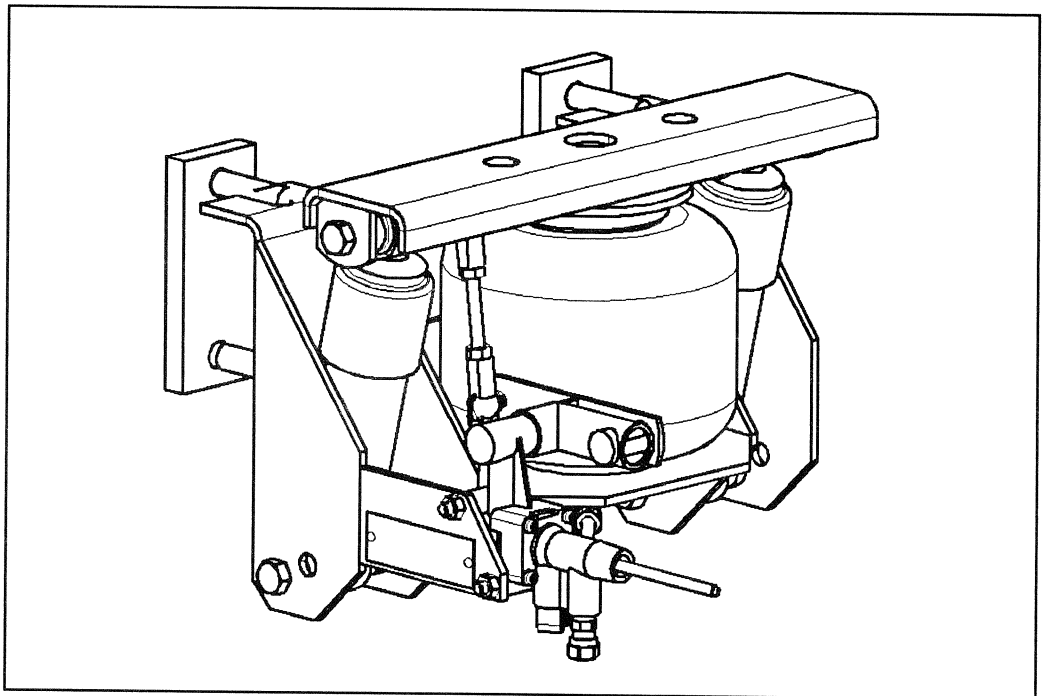

INSTALLATION INSTRUCTIONS PARTS LIST

MCR600 (2610-0000)



Link Mfg. Ltd.
223 15th St. N.E.
Sioux Center, IA USA
51250-2120

(712) 722-4874
Fax (712) 722-4876

**QUESTIONS?
CALL CUSTOMER
SERVICE
1-800-222-6283**

The **CABMATE MODEL MCR600** fits most Mack R 600 tractors. It replaces the original rear cab mounting bracket.

UNIT WEIGHT: 31.8 LB.

NET WEIGHT ADDED: 24.4 LB.

CABMATE MODEL MCR600

Review the Parts List on page 3 to become familiar with the different components of the CABMATE.

IMPORTANT: Due to many chassis variables caused by installation of special equipment or options, the fit of the MCR600 CABMATE may be affected and should be evaluated before beginning installation.

IMPORTANT: Installation of the CABMATE system will allow the cab to move freely. Before starting installation, check clearances between the cab and any objects the cab may contact when it moves (1 1/2 inches of clearance should be sufficient). The clearance of components that are affected by cab movement, such as exhaust and radiator systems, must also be evaluated.

Hood rollers, radiator brackets, air intake, and cab mounted exhaust systems may also need alteration. Contact your nearest O.E.M. dealer for additional parts to complete installation.

IMPORTANT: Before beginning installation, measure the distance from the bottom of the cab to the frame. If the distance is approximately 4 5/8 inches, the 5/8 x 6 mounting bolts are required. If the distance is approximately 5 5/8 inches the 5/8 x 7 mounting bolts and the One Inch Spacer (2610-3000) are required.

A. Remove the two rear mounting bolts from the cab and securely prop up the cab. Carefully cut the cab mounting bracket from the cab support crossmember. **NOTE:** After the mounting bracket is removed there must be no rough edges extending 1/4 inch or more from the crossmember. (Fig. 1)

B. Attach the Height Control Valve to the Unit Bottom as shown on page 3. Slide the CABMATE between the cab and the crossmember from underneath the cab. Using the Mount Straps and the 1/2 mount bolts supplied by Link Mfg., (Item No.'s 8, 14, and 18 on Parts List), loosely mount the Unit Bottom to the crossmember. (Fig. 2)

C. Using the correct length bolt, and One Inch Spacer if required, mount the Unit Top to the cab frame. **SECURELY TIGHTEN ALL FASTENERS.** Lower the cab completely.

D. See page 2 for plumbing instructions and height adjustments.

E. **IMPORTANT:** After plumbing and height control adjustments are completed, temporarily adjust the CABMATE to its maximum upward position. There must be a 1/4" to 3/8" gap between the cab and the hood. Adjust the hood hinge forward as necessary. (Fig. 3).

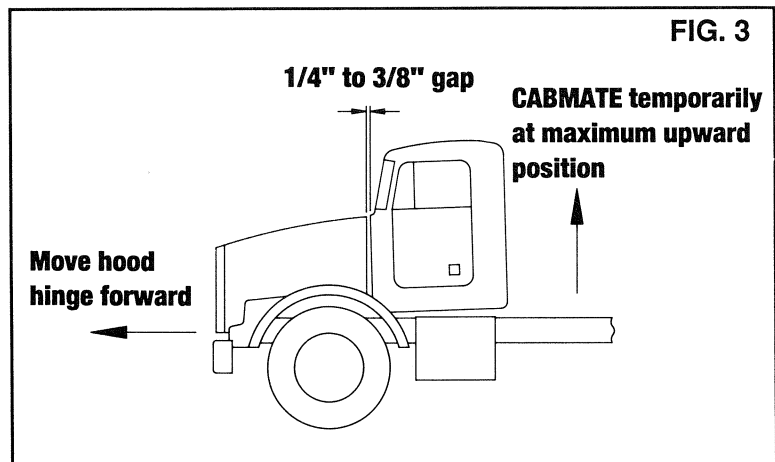
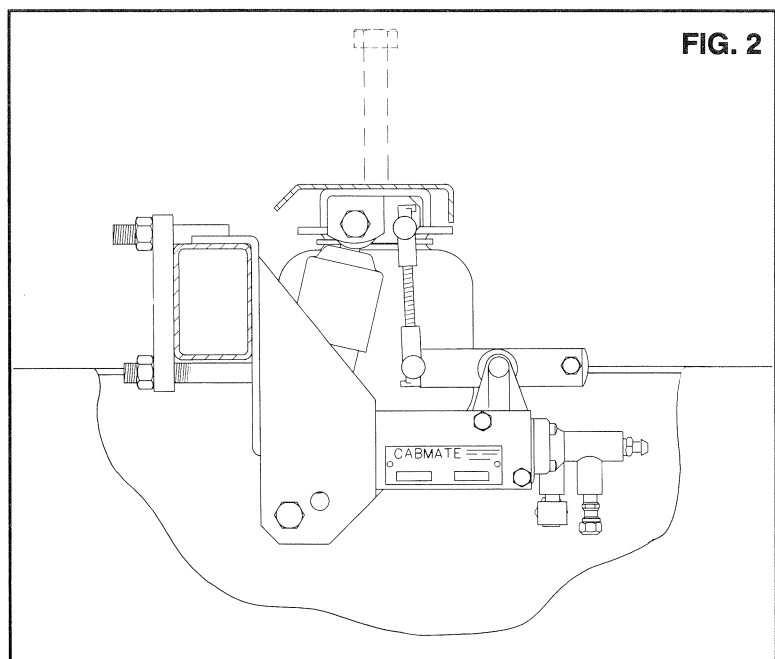
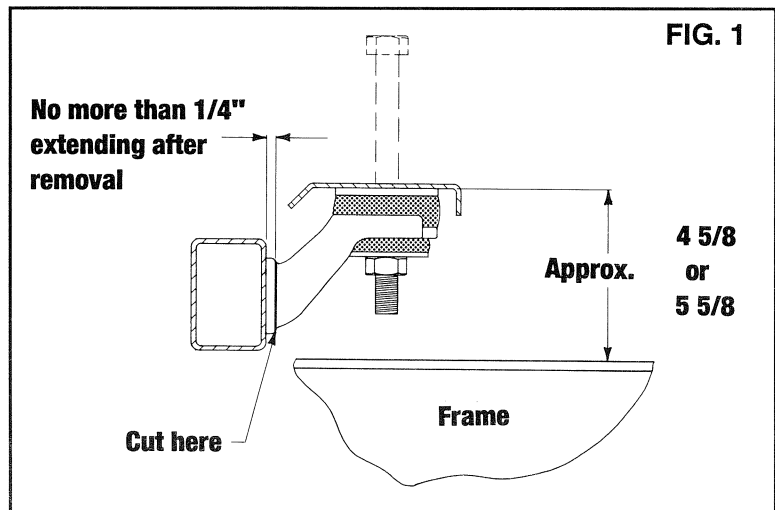

PLUMBING INSTRUCTIONS

WARNING: FOR SAFETY PURPOSES THE CABMATE MUST BE SUPPLIED FROM A PRESSURE PROTECTED CIRCUIT. IN THE EVENT OF AN AIR LEAK IN THE CAB SUSPENSION, FAILURE TO PROVIDE A PRESSURE PROTECTED CIRCUIT MAY CAUSE LOSS OF AIR PRESSURE TO VITAL SYSTEMS ON THE VEHICLE.

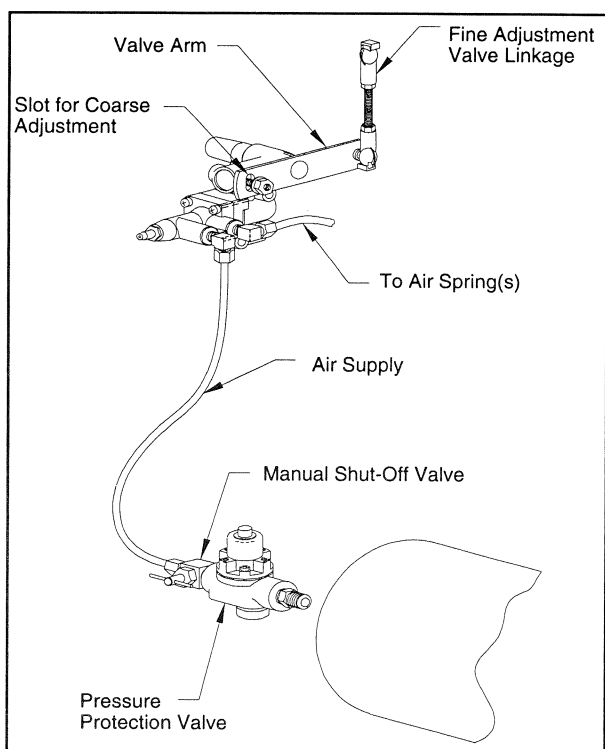

WARNING: LOSS OR APPLICATION OF AIR PRESSURE TO CABMATE WILL CAUSE SUDDEN MOVEMENT OF THE CAB. PRIOR TO INSTALLING OR PERFORMING ANY MAINTENANCE, BLOCK UP THE CABMATE TO PREVENT THE POSSIBILITY OF INJURY.

WARNING: CONNECT THE CABMATE DIRECTLY TO THE MAIN AIR TANK. YOU WILL NEED AN AIR PRESSURE PROTECTION VALVE IN THE LINE. (INCLUDED IN THE PRESSURE PROTECTION KIT, LINK MFG. PART NO. 1350-0000). DO NOT USE AN AIR PRESSURE REGULATOR!

A. With the tank at 0 p.s.i., remove the existing plug or fitting from the desired port.

B. Apply joint compound to the fittings and install the pressure protection kit. **DO NOT USE TEFLON TAPE.** Be sure that the arrows on the valve are pointing in the direction of air flow and the vent hole is pointed down. **NOTE:** Additional fittings/reducers may be required to attach the hex nipple to the main air tank.

C. Run the 1/4" airline from the shut-off valve to the CABMATE. Be sure that the airline has enough clearance so that there are no pinch points that may restrict or cut the airline. Secure the airline using the cable ties supplied by Link Mfg.

D. Tighten all plumbing fittings. Then, with the system at operating pressure (90 to 110 p.s.i), open the Manual Shut-off Valve to supply air to the CABMATE. (There is an approximate 5 second delay in the Height Control Valve.) Check the system for air leaks.

E. Check for proper operation of the height control valve. Disconnect the valve linkage from the valve arm. Push the valve arm down 45° and hold for 5 seconds, air should be flowing into the air spring(s). Return the valve

arm to the neutral position. Push the valve arm up 45° and hold for 5 seconds, air should be evacuating from the air spring(s). Return the valve arm to the neutral position; no air should flow. Reconnect the valve linkage to the valve arm.

HEIGHT ADJUSTMENTS

Measure the design height of the air spring(s). The height should be 5 1/2 inches ± 1/16. To change the height, disconnect one end of the valve linkage and adjust accordingly. Tighten the lock nuts on the valve linkage. The valve arm has a slot which will allow for coarse adjustment also. (See diagram above.)

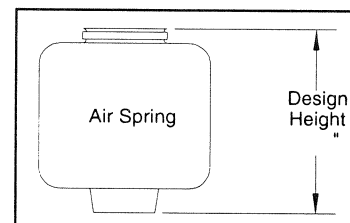

MAINTENANCE

CABMATES need no lubrication and little maintenance. The following components should be checked at the time the truck is being serviced. However, immediate corrective action should be taken if a serious malfunction occurs.

COMPONENT	POSSIBLE PROBLEM	CORRECTIVE ACTION	TORQUE
Airlines	Air leaks	Replace airline	Compression Nut Hand Tight + 1 Turn
Fittings	Air leaks	Remove fitting and apply fresh joint compound. Reinstall fitting, but Do Not Overtighten. Do not use Teflon tape.	AIR SPRING MATERIAL Metal Plastic 15 Hand Tight Ft. Lbs. + 1 Turn
Air Springs	A. Improper height B. Air leakage	A. Adjust valve linkage to maintain proper air spring height. B. Replace air spring.	Size Metal Plastic 3/8 25 Ft. Lbs 4 Ft. Lbs 1/2 28 Ft. Lbs 10 Ft. Lbs 3/4 30 Ft. Lbs 10 Ft. Lbs
Height Control Valve*	A. Air leakage from joint between valve halves. B. Air springs will not inflate when weight is added to the cab. C. Air springs will not deflate when weight is removed from the cab.	A. Tighten 4 Phillips head screws. B. Replace valve. C. Replace valve.	30 In. Lbs. 1/4 Mount Fasteners 10 Ft. Lbs.
Shock Absorber	Insufficient dampening effect	Replace shocks	45 Ft. Lbs.
Lateral Control Rod	A. Loose nuts on lateral control rod bolts B. Worn bushings	A. Tighten securely to clamp the inner sleeve. B. Replace lateral control rod.	40 Ft. Lbs.

IMPORTANT: Periodically check the tightness of all fasteners.

* **Note:** If you attempt to disassemble or adjust fittings on the height control valve, it will void your warranty. Contact Link Manufacturing for assistance.

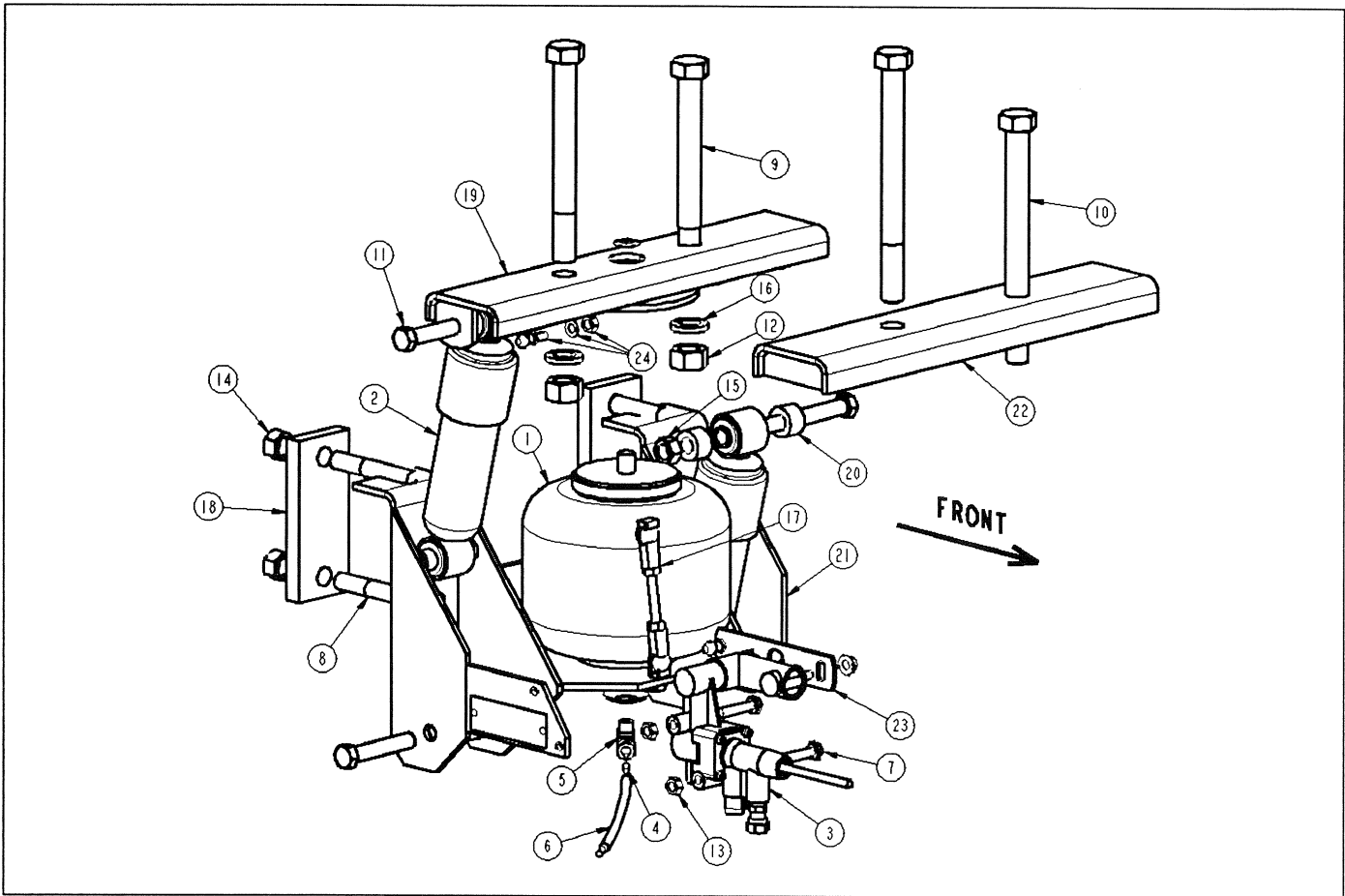

**CABMATE® MODEL MCR600
PARTS LIST**

ITEM #	PART #	PART DESCRIPTION	QTY.
1	1102-A043	Air Spring With Attachments	1
2	1201-0012	Shock Absorber	2
3	1301-0010	Valve-Control, Height	1
4	1302-1038	.25 Tube Support	2
5	1302-1105	Elbow, 1/4 TB 1/8 M-NPT	1
6	1302-0090	.25 Airline	0.5'
7	1401-0816	1/4 X 2 UNC Hex Cap Screw (Grade 5)	2
8	1401-1628	1/2 X 3 1/2 UNC Hex Cap Screw (Grade 5)	2
9	1401-2048	5/8 X 6 UNC Hex Cap Screw (Grade 5)	2
10	1401-2056	5/8 X 7 UNC Hex Cap Screw (Grade 5)	2
11	1403-1428	7/16 X 3 1/2 UNF Hex Cap Screw (Grade 5)	4
12	1470-2000	5/8 UNC Hex Nut (Grade B)	2
13	1476-0800	1/4 UNC Hex Center Lock Nut (Grade B)	2
14	1476-1600	1/2 UNC Hex Center Lock Nut (Grade B)	4
15	1477-1400	7/16 UNF Hex Center Lock Nut (Grade B)	4
16	1485-2000	5/8 Lock Washer	2
17	1500-0245	Linkage-Valve, Height Control (3.88)	1
18	2610-0001	Mount Strap	2
19	2610-1000	Bracket-Mount, Cab	1
20	2610-1005	Top Shock Spacer	4
21	2610-2000	Bracket-Mount, Crossmember	1
22	2610-3000	Spacer-Mount, Cab	1
23	2990-0700	Assembly-Arm, Valve	1
24	2991-0026	Kit-Pivot Ball	1
Not Shown	1350-0000	Kit-Protection, Pressure	1