

Link

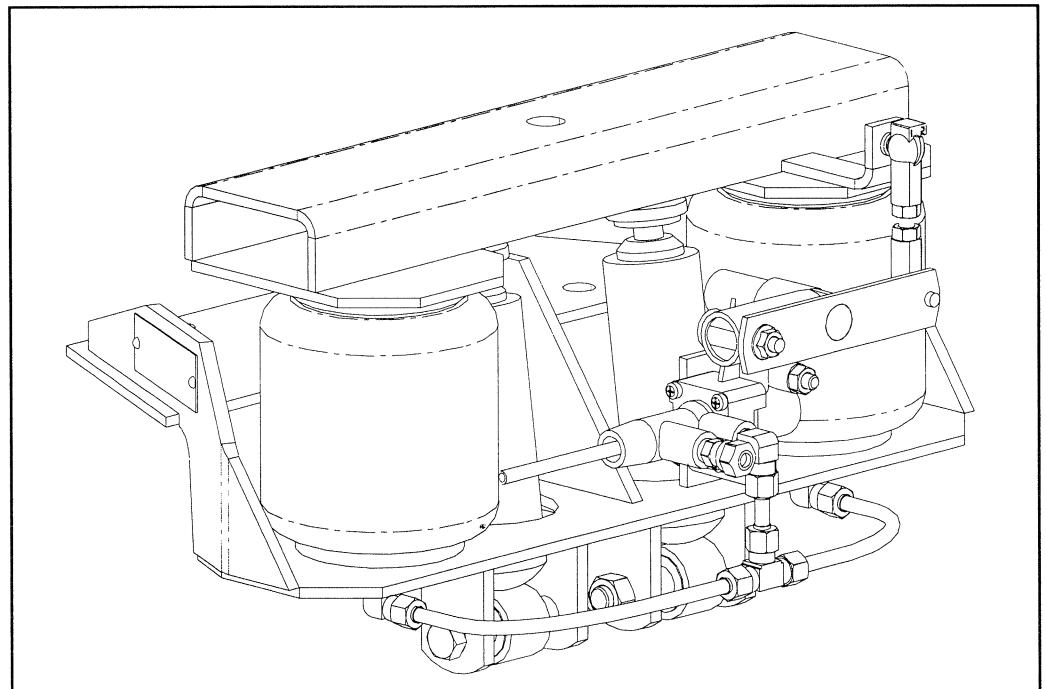

INSTALLATION INSTRUCTIONS PARTS LIST

GMC816 (2365-0000)



Link Mfg. Ltd.
223 15th St. N.E.
Sioux Center, IA USA
51250-2120

(712) 722-4874
Fax (712) 722-4876

**QUESTIONS?
CALL CUSTOMER
SERVICE
1-800-222-6283**

The **CABMATE MODEL GMC816** fits most 1979 and newer GMC General Conventional Trucks, measuring 108" BBC or 116" BBC. It replaces the original rear cab mount, GMC Part Nos. 718544, 2058799 or 15502957.

UNIT WEIGHT: 24.3 LB.

NET WEIGHT ADDED: 20.5 LB.

CABMATE MODEL GMC816

Review the Parts List on page 3 to become familiar with the different components of the CABMATE.

IMPORTANT: Due to many chassis variables caused by installation of special equipment or options, the fit of the GMC816 CABMATE may be affected and should be evaluated before beginning installation.

IMPORTANT: Installation of the CABMATE system will allow the cab to move freely. Before starting installation, check clearances between the cab and any objects the cab may contact when it moves (1 1/2 inches of clearance should be sufficient). The clearance of components that are affected by cab movement, such as exhaust and radiator systems, must also be evaluated.

A. Remove the original cab mount bolt. Securely prop up the cab. Remove the four crossmember mount bolts, stock rear cab mount and isolators. **SAVE** the four crossmember mount bolts for later use (Fig. 1).

B. FOR TRUCKS WITH 116" BBC
Place the unit on the crossmember with the valve to the rear of the truck (Fig. 2).
FOR TRUCKS WITH 108" BBC
Place the unit on the crossmember with the valve to the front of the truck (Fig. 3).

C. Loosely fasten the Unit Bottom to the crossmember using the stock mount bolts (Fig. 2 & 3).

D. Lower the cab until it touches the top of the CABMATE. Fasten the Unit Top to the cab using the 5/8" mount hardware (Nos. 8, 11, 15 and 16 on Parts List) (Fig. 2 & 3). **SECURELY TIGHTEN ALL FASTENERS.** Lower the cab completely.

E. See page 2 for plumbing instructions and height adjustments.

F. IMPORTANT: After plumbing and height control adjustments are completed, temporarily adjust the CABMATE to its maximum upward position. There must be a 1/4" to 3/8" gap between the cab and the hood. Adjust the hood hinge forward as necessary (Fig. 4).

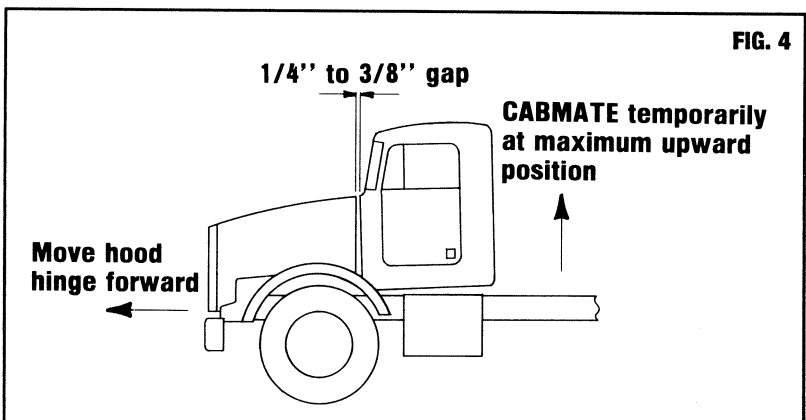
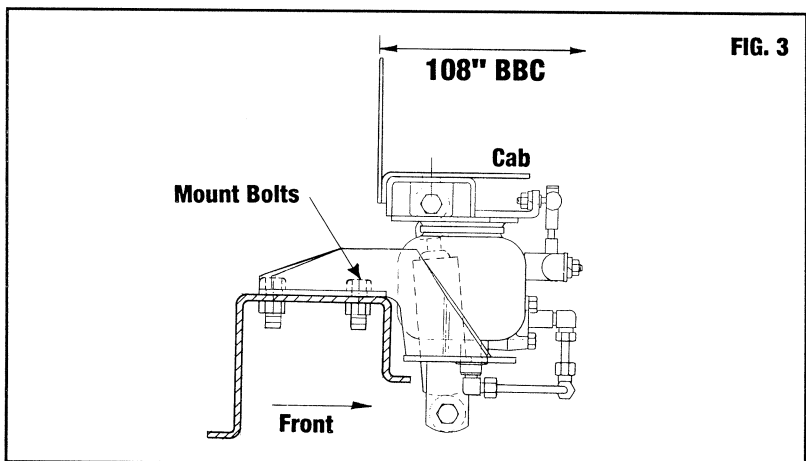
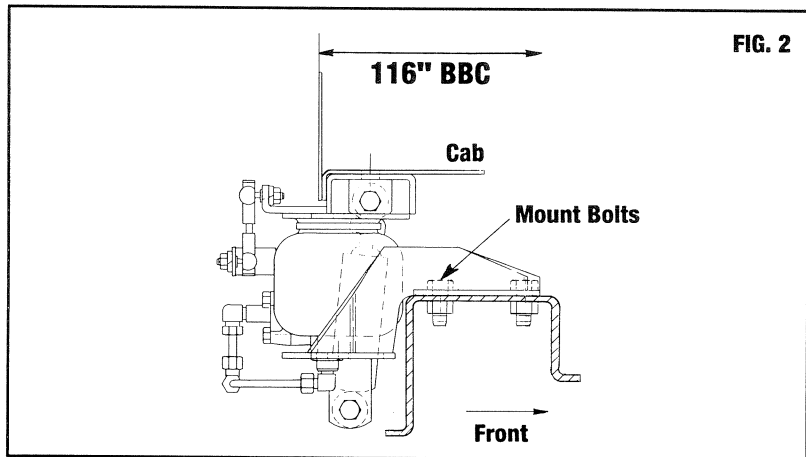
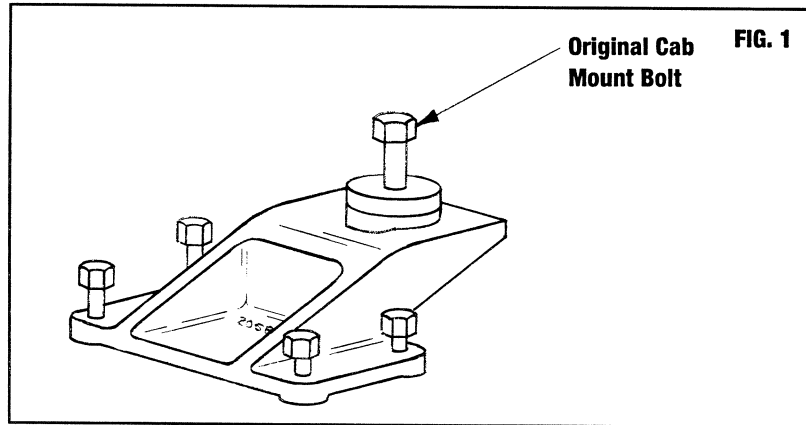

PLUMBING INSTRUCTIONS

WARNING: FOR SAFETY PURPOSES THE CABMATE MUST BE SUPPLIED FROM A PRESSURE PROTECTED CIRCUIT. IN THE EVENT OF AN AIR LEAK IN THE CAB SUSPENSION, FAILURE TO PROVIDE A PRESSURE PROTECTED CIRCUIT MAY CAUSE LOSS OF AIR PRESSURE TO VITAL SYSTEMS ON THE VEHICLE.

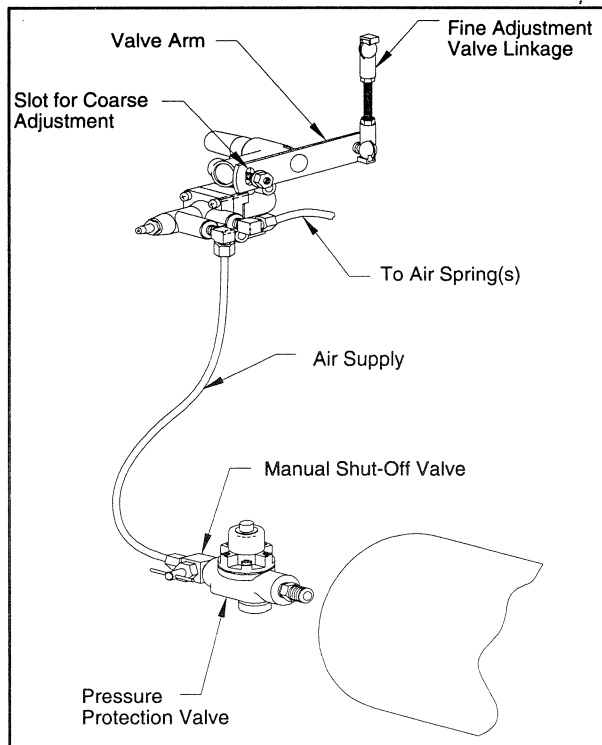

WARNING: LOSS OR APPLICATION OF AIR PRESSURE TO CABMATE WILL CAUSE SUDDEN MOVEMENT OF THE CAB. PRIOR TO INSTALLING OR PERFORMING ANY MAINTENANCE, BLOCK UP THE CABMATE TO PREVENT THE POSSIBILITY OF INJURY.

WARNING: CONNECT THE CABMATE DIRECTLY TO THE MAIN AIR TANK. YOU WILL NEED AN AIR PRESSURE PROTECTION VALVE IN THE LINE. (INCLUDED IN THE PRESSURE PROTECTION KIT, LINK MFG. PART NO. 1350-0000). DO NOT USE AN AIR PRESSURE REGULATOR!

- A. With the tank at 0 p.s.i., remove the existing plug or fitting from the desired port.
- B. Apply joint compound to the fittings and install the pressure protection kit. **DO NOT USE TEFLON TAPE.** Be sure that the arrows on the valve are pointing in the direction of air flow and the vent hole is pointed down. **NOTE:** Additional fittings/reducers may be required to attach the hex nipple to the main air tank.
- C. Run the 1/4" airline from the shut-off valve to the CABMATE. Be sure that the airline has enough clearance so that there are no pinch points that may restrict or cut the airline. Secure the airline using the cable ties supplied by Link Mfg.
- D. Tighten all plumbing fittings. Then, with the system at operating pressure (90 to 110 p.s.i.), open the Manual Shut-off Valve to supply air to the CABMATE. (There is an approximate 5 second delay in the Height Control Valve.) Check the system for air leaks.
- E. Check for proper operation of the height control valve. Disconnect the valve linkage from the valve arm. Push the valve arm down 45° and hold for 5 seconds, air should be flowing into the air spring(s). Return the valve

arm to the neutral position. Push the valve arm up 45° and hold for 5 seconds, air should be evacuating from the air spring(s). Return the valve arm to the neutral position; no air should flow. Reconnect the valve linkage to the valve arm.

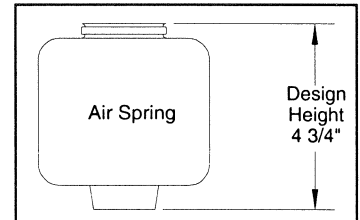

HEIGHT ADJUSTMENTS

Measure the design height of the air spring(s). The height should be 4 3/4 inches ± 1/16. To change the height, disconnect one end of the valve linkage and adjust accordingly. Tighten the lock nuts on the valve linkage. The valve arm has a slot which will allow for coarse adjustment also. (See diagram above.)

MAINTENANCE

CABMATES need no lubrication and little maintenance. The following components should be checked at the time the truck is being serviced. However, immediate corrective action should be taken if a serious malfunction occurs.

COMPONENT	POSSIBLE PROBLEM	CORRECTIVE ACTION	TORQUE
Airlines	Air leaks	Replace airline	Compression Nut Hand Tight + 1 Turn
Fittings	Air leaks	Remove fitting and apply fresh joint compound. Reinstall fitting, but Do Not Overtighten. Do not use Teflon tape.	AIR SPRING MATERIAL Metal Plastic 15 Hand Tight Ft. Lbs. + 1 Turn
Air Springs	A. Improper height B. Air leakage	A. Adjust valve linkage to maintain proper air spring height. B. Replace air spring.	Size Metal Plastic 3/8 25 Ft. Lbs 4 Ft. Lbs 1/2 28 Ft. Lbs 10 Ft. Lbs 3/4 30 Ft. Lbs 10 Ft. Lbs
Height Control Valve*	A. Air leakage from joint between valve halves. B. Air springs will not inflate when weight is added to the cab. C. Air springs will not deflate when weight is removed from the cab.	A. Tighten 4 Phillips head screws. B. Replace valve. C. Replace valve.	30 In. Lbs. 1/4 Mount Fasteners 10 Ft. Lbs.
Shock Absorber	Insufficient dampening effect	Replace shocks	45 Ft. Lbs.
Lateral Control Rod	A. Loose nuts on lateral control rod bolts B. Worn bushings	A. Tighten securely to clamp the inner sleeve. B. Replace lateral control rod.	40 Ft. Lbs.

IMPORTANT: Periodically check the tightness of all fasteners.

* **Note:** If you attempt to disassemble or adjust fittings on the height control valve, it will void your warranty. Contact Link Manufacturing for assistance.

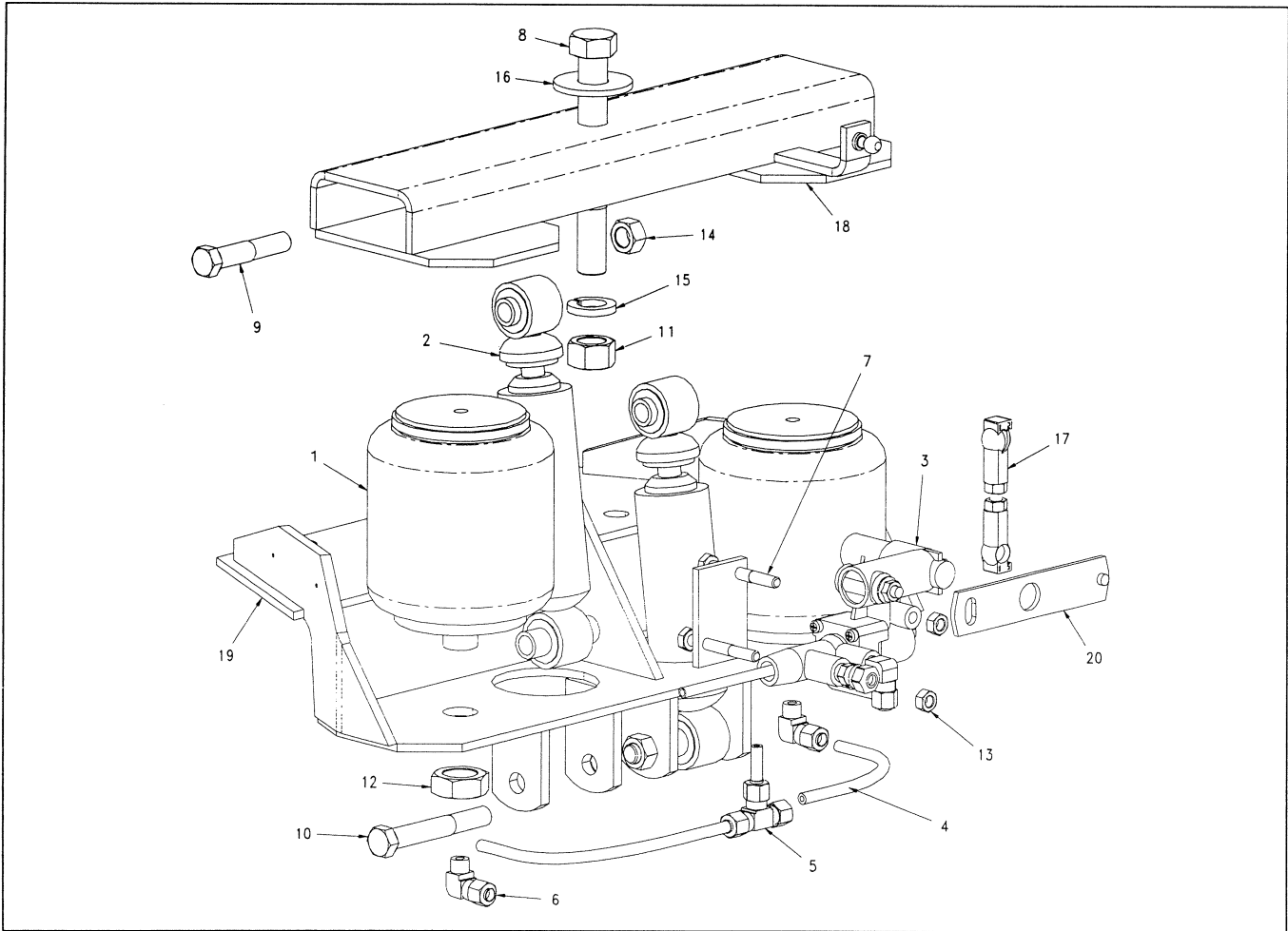

**CABMATE® MODEL GMC816
PARTS LIST**

ITEM #	PART #	PART DESCRIPTION	QTY.
1	1102-0023	Spring-Air	2
2	1202-0012	Shock Absorber	2
3	1301-0025	Valve-Control, Height	1
4	1302-0090	0.250 Airline	1.1 ft.
5	1302-1083	Union Tee, 1/4 TB	1
6	1302-1105	Elbow, 1/4 TB 1/8 M-NPT	2
7	1401-0816	1/4 X 2 UNC Hex Cap Screw (Grade 5)	2
8	1401-2040	5/8 X 5 UNC Hex Cap Screw (Grade 5)	1
9	1403-1418	7/16 X 2 1/4 UNF Hex Cap Screw (Grade 5)	2
10	1403-1424	7/16 X 3 UNF Hex Cap Screw (Grade 5)	2
11	1470-2000	5/8 UNC Hex Nut (Grade B)	1
12	1475-2400	3/4 UNF Jam Nut	2
13	1476-0800	1/4 UNC Hex Center Lock Nut (Grade B)	2
14	1477-1400	7/16 UNF Hex Center Lock Nut (Grade B)	4
15	1485-2000	5/8 Lock Washer	1
16	1487-2000	5/8 Type A Plain Washer	1
17	1500-0235	Linkage-Valve, Height Control (2.63)	1
18	2365-1000	Unit Top	1
19	2365-2000	Unit Bottom	1
20	2990-0700	Assembly-Arm, Valve	1
Not Shown	1350-0000	Kit-Protection, Pressure	1