

INSTALLATION INSTRUCTIONS

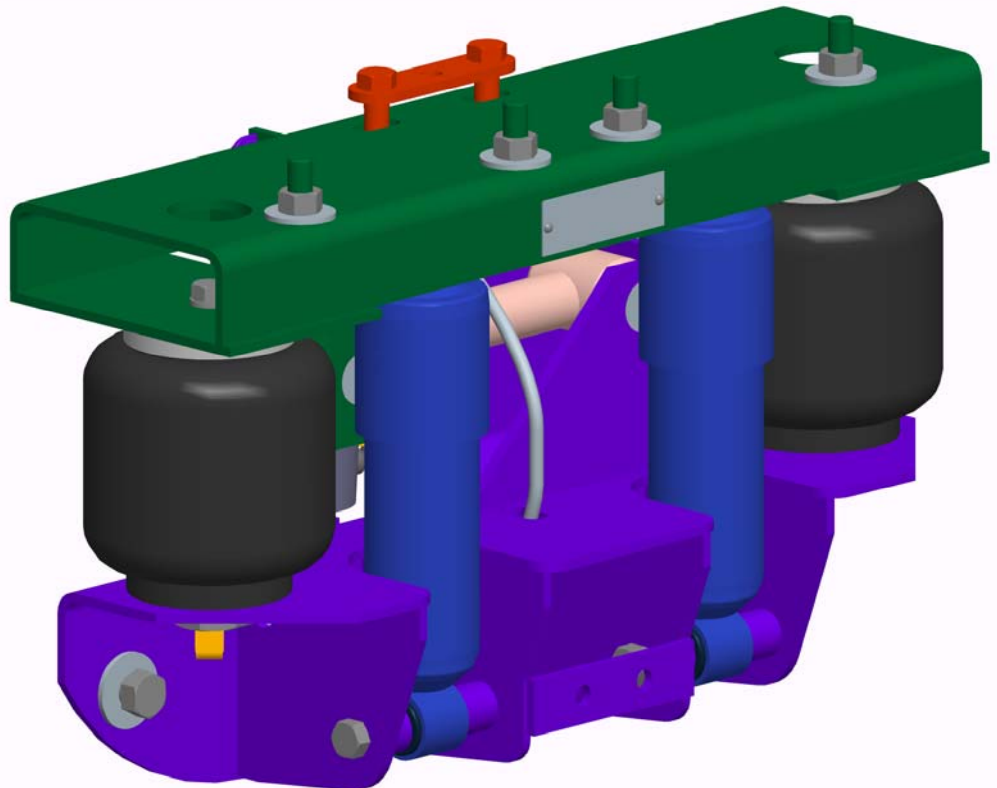

FRT106HD-A (2266-E000)



The **CABMATE MODEL FRT106HD-A** fits most 1991 and newer Freightliner FL60, FL70, FL80, and FL106* Series Trucks. It replaces the original rear cab mount bracket, Freightliner Part No's. 680-317-00-40 or 680-317-04-40.

-An air compressor system is required

-Trucks with horizontal muffler and vertical stack may require some exhaust modifications.

*FL-106 Series Trucks will require a Cab Spacer, Link Mfg. Part No. (2265-9000). **Specify when ordering.**

UNIT WEIGHT : 30.8 LB.

NET WEIGHT ADDED: 3.9 LB.

Link mfg. Ltd.
223 15th St. N.E.
Sioux Center, IA USA
51250-2120

(712) 722-4874
Fax (712) 722-4876

**QUESTIONS?
CALL CUSTOMER
SERVICE
1-800-222-6283**

CABMATE MODEL FRT106HD-A

Review the Parts List on page 3 to become familiar with the different components of the CABMATE.

IMPORTANT: Due to many chassis variables caused by installation of special equipment or options, the fit of the FRT106HD-A CABMATE may be affected and should be evaluated before beginning installation.

IMPORTANT: Installation of the CABMATE system will allow the cab to move freely. Before starting installation, check clearances between the cab and any objects the cab may contact when it moves (1 1/2 inches of clearance should be sufficient). The clearance of components that are affected by cab movement, such as exhaust and radiator systems, must also be evaluated.

IMPORTANT: FL106 Series trucks require Cab Spacer Installation. See insert for installation instructions.

A. Remove the eight mount bolts from the upper cab mount brackets as shown in (Fig. 1). Securely prop up the cab and remove the upper cab mount brackets. Remove the four huck fasteners and the lower cab mounts.

B. Loosely fasten the Unit Bottom to the crossmember using the 1/2 X 1 1/4 Grade 8 Bolts supplied by Link Mfg. (No.'s 12, 22, and 27 from the Parts List) (Fig. 2).

C. Slowly lower the cab until it touches the top of the CABMATE. Fasten the Unit Top to the cab frame using the mounting hardware supplied by Link Mfg. (No.'s 20, 21, 26 and 37 from the Parts List) **SECURELY TIGHTEN ALL FASTENERS.** Lower the cab completely.

D. Mount the Auxiliary Jounce Travel Limiter (Item No.'s 33 and 34 from the Parts List on Page 3) using the 1/2 X 1 1/4 Bolts supplied by Link Mfg. (No.'s 11, 21, and 26 from the Parts List) (Fig. 2).

E. See page 2 for plumbing instructions and height adjustments.

F. Raise the hood and remove the original hood brackets. Install the hood brackets supplied by Link Mfg. (No.'s 31 and 32 from the Parts List). Reaffix any components that were attached to the original hood brackets.

G. **IMPORTANT:** After plumbing and height control adjustment are completed, the hood hinge must be adjusted to satisfy the following:

1. Temporarily adjust the CABMATE to its maximum upward position. There must be a 1/4" to 3/8" gap between the cab and the hood.

2. With the CABMATE at design height, the hood support rod should be in the upper 1/3 of the hood support bracket slot (Fig. 3).

NOTE: Upper hood support bracket may also be adjusted to meet this requirement.

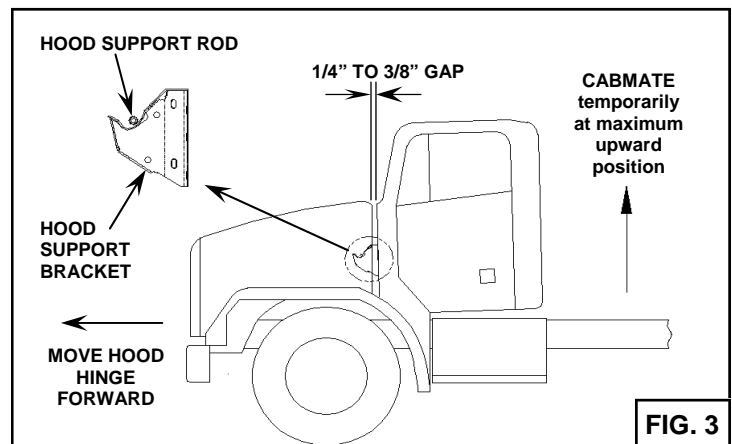
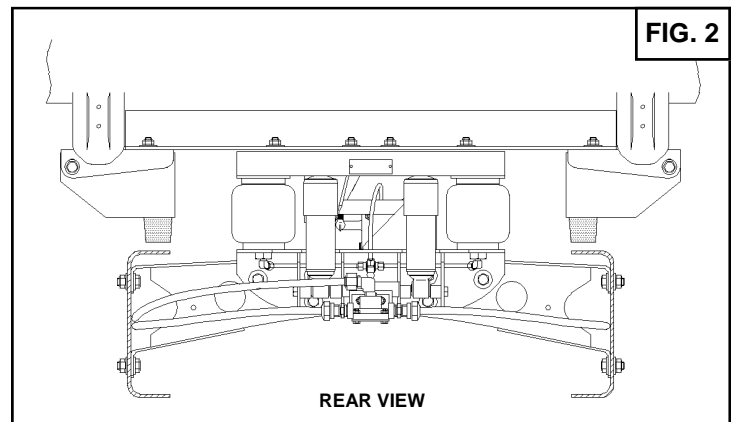
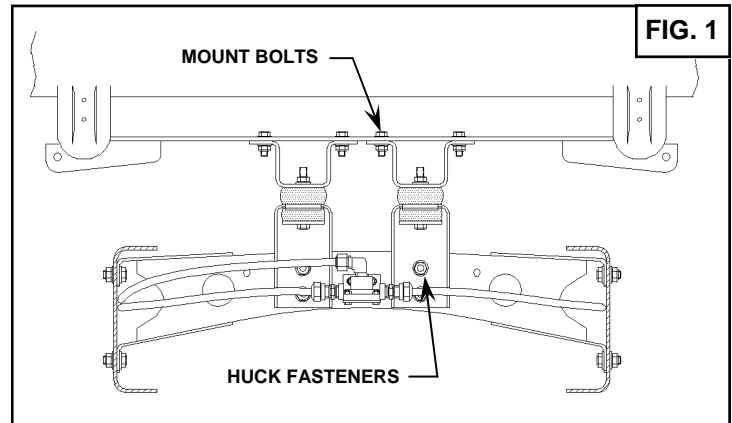

FL106 SERIES CAB SPACER (2265-9000)

Review the Parts List on page 3 to become familiar with the different components of the CABMATE.

IMPORTANT: Due to many chassis variables caused by installation of special equipment or options, the fit of the FRT106BC/FRT106HD/FRT153BC CABMATE may be affected and should be evaluated before beginning installation.

IMPORTANT: Installation of the CABMATE system will allow the cab to move freely. Before starting installation, check clearances between the cab and any objects the cab may contact when it moves (1 1/2 inches of clearance should be sufficient). The clearance of components that are affected by cab movement, such as exhaust and radiator systems, must also be evaluated.

IMPORTANT: Installation of the CABMATE Model FRT106BC/FRT106HD/FRT153BC on FL106 Series Trucks requires that the Cab Spacer be used. If the Cab Spacer is installed the Auxiliary Travel Limiters are not necessary.

- A. Remove the eight mount bolts from the upper cab mount brackets as shown in (Fig. 1). Securely prop up the cab and remove the upper cab mount brackets. Remove the four huck fasteners and the lower cab mounts. **NOTE:** Save the eight mount bolts for later use.
- B. Loosely fasten the Cab Spacer to the cab frame using the eight mount bolts from the upper cab mount brackets (Fig. 2).
- C. Loosely fasten the Unit Bottom to the crossmember using the 1/2 X 1 1/4 Grade 8 Bolts supplied by Link Mfg (Fig. 2).
- D. Slowly lower the cab until the Cab Spacer touches the top of the CABMATE. Fasten the Unit Top to the Cab Spacer using the mounting hardware supplied by Link Mfg. **SECURELY TIGHTEN ALL FASTENERS.** Lower the cab completely.
- E. See page 2 for plumbing instructions and height adjustments.
- F. Raise the hood and remove the original hood brackets. Install the hood brackets supplied by Link Mfg. Reaffix any components that were attached to the original hood brackets.
- G. **IMPORTANT:** After plumbing and height control adjustment are completed, the hood hinge must be adjusted to satisfy the following:
 1. Temporarily adjust the CABMATE to its maximum upward position. There must be a 1/4" to 3/8" gap between the cab and the hood.
 2. With the CABMATE at design height, the hood support rod should be in the upper 1/3 of the hood support bracket slot (Fig. 3).**NOTE:** Upper hood support bracket may also be adjusted to meet this requirement.

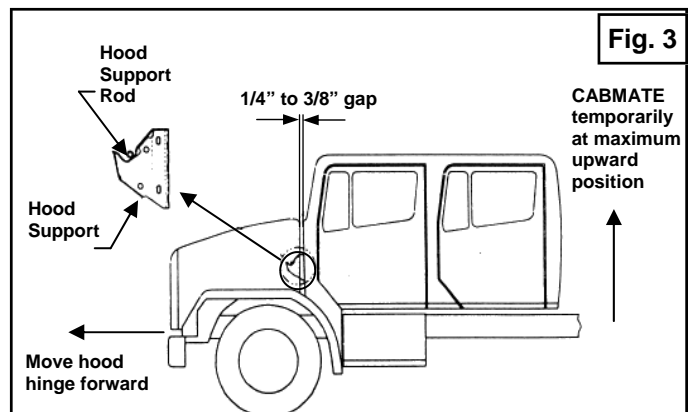
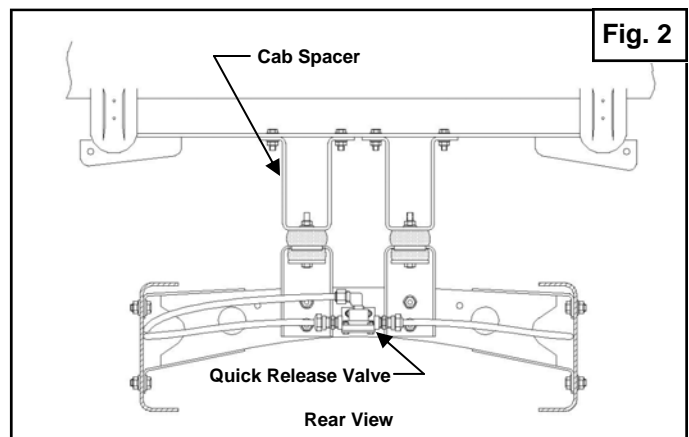
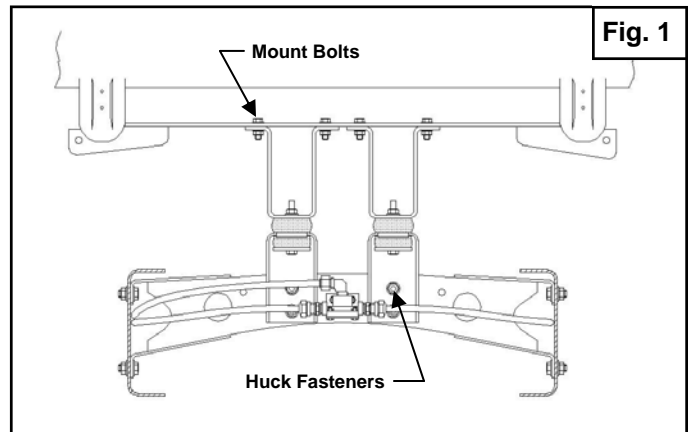

PAGE LEFT INTENTIONALLY BLANK

-2 CS-

PLUMBING INSTRUCTIONS

WARNING: FOR SAFETY PURPOSES THE CABMATE MUST BE SUPPLIED FROM A PRESSURE PROTECTED CIRCUIT. IN THE EVENT OF AN AIR LEAK IN THE CAB SUSPENSION, FAILURE TO PROVIDE A PRESSURE PROTECTED CIRCUIT MAY CAUSE LOSS OF AIR PRESSURE TO VITAL SYSTEMS ON THE VEHICLE.

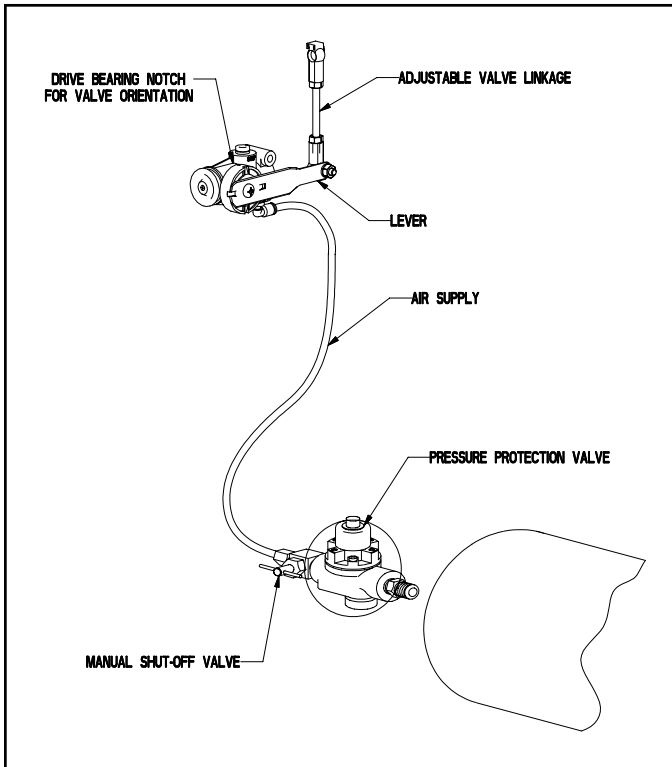

WARNING: LOSS OR APPLICATION OF AIR PRESSURE TO CABMATE WILL CAUSE SUDDEN MOVEMENT OF THE CAB. PRIOR TO INSTALLING OR PERFORMING MAINTENANCE, BLOCK UP THE CABMATE TO PREVENT THE POSSIBILITY OF INJURY.

WARNING: CONNECT THE CABMATE DIRECTLY TO THE MAIN AIR TANK. YOU WILL NEED AN AIR PRESSURE PROTECTION VALVE IN THE LINE. (INCLUDED IN THE PRESSUREPROTECTION KIT. LINK MFG. PART NO. 1350-0000). DO NOT USE AN AIR PRESSURE REGULATOR!

A. With the tank at 0 p.s.i., remove the existing plug or fitting from the desired port.

B. Apply joint compound to the fittings and install the pressure protection kit. **DO NOT USE TEFLON TAPE.** Be sure that the arrows on the valve are pointing in the direction of air flow and the vent hole is pointed down. **NOTE:** Additional fittings/reducers may be required to attach the hex nipple to the main air tank.

C. Run the 1/4" airline from the shut-off valve to the CABMATE. Be sure that the airline has enough clearance so that there are no pinch points that may restrict or cut the airline. Secure the airline using the cable ties supplied by Link Mfg.

D. Tighten all plumbing fittings. Then, with the system at operating pressure (90 to 110 p.s.i), open the Manual Shut-off Valve to supply air to the CABMATE. Check the system for air leaks.

E. Check for proper operation of the height control valve. Disconnect the valve linkage from the lever. Push the lever down 45°, air should flow into the air spring(s). Return the lever to the neutral position. Push the lever up 45°, air should exhaust from the air spring(s). Return the lever to the neutral

position; no air should flow. Reconnect the valve linkage to the lever.

HEIGHT ADJUSTMENTS

Measure the design height of the air spring(s). The height should be 5.00 inches \pm 1/16. To change the height, disconnect one end of the valve linkage and adjust accordingly.

MAINTENANCE

CABMATES need no lubrication and little maintenance. The following components should be checked at the time the truck is being serviced. However, immediate corrective action should be taken if a serious malfunction occurs.

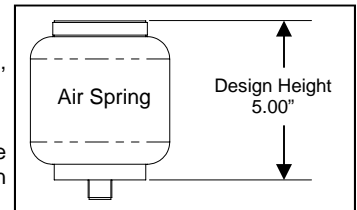

COMPONENT	POSSIBLE PROBLEM	CORRECTIVE ACTION	TORQUE
Airlines	Air leaks	Replace airline	Compression Nut Hand Tight + 1 Turn
Fittings	Air leaks	Remove fitting and apply fresh joint compound. Reinstall fitting, but Do Not Overtighten. Do not use teflon tape.	Threaded into: Metal Plastic 15 Hand Tight Ft. Lbs. + 1 Turn
Air Springs	A. Improper height B. Air leakage	A. Adjust valve linkage to maintain proper air spring height. B. Replace air spring.	Size Metal Plastic 3/8 25 Ft. Lbs 04 Ft. Lbs 1/2 28 Ft. Lbs 10 Ft. Lbs 3/4 30 Ft. Lbs 10 Ft. Lbs
Height Control Valve	Air spring(s) will not inflate when weight is added to the cab; OR Air spring(s) will not deflate when weight is removed from the cab.	A. Inspect valve to insure drive bearing notch is located on "SUSP" port side of valve. If not, loosen lever screw (but do not remove completely) and pull lever loose from drive bearing, rotate drive bearing until the bearing notch is in the correct position and resecure lever by tightening lever screw. B. Replace Valve	1/4 Mount Fasteners 10 Ft. Lbs. Bearing Screw 40-50 InLbs.
Shock Absorber	Insufficient dampening effect	Replace shocks	45 Ft. Lbs.
Lateral Control Rod	A. Loose nuts on lateral control rod bolts B. Worn bushings.	A. Tighten securely to clamp the inner sleeve. B. Replace lateral control rod.	40 Ft. Lbs.

IMPORTANT: Periodically check the tightness of all fasteners.

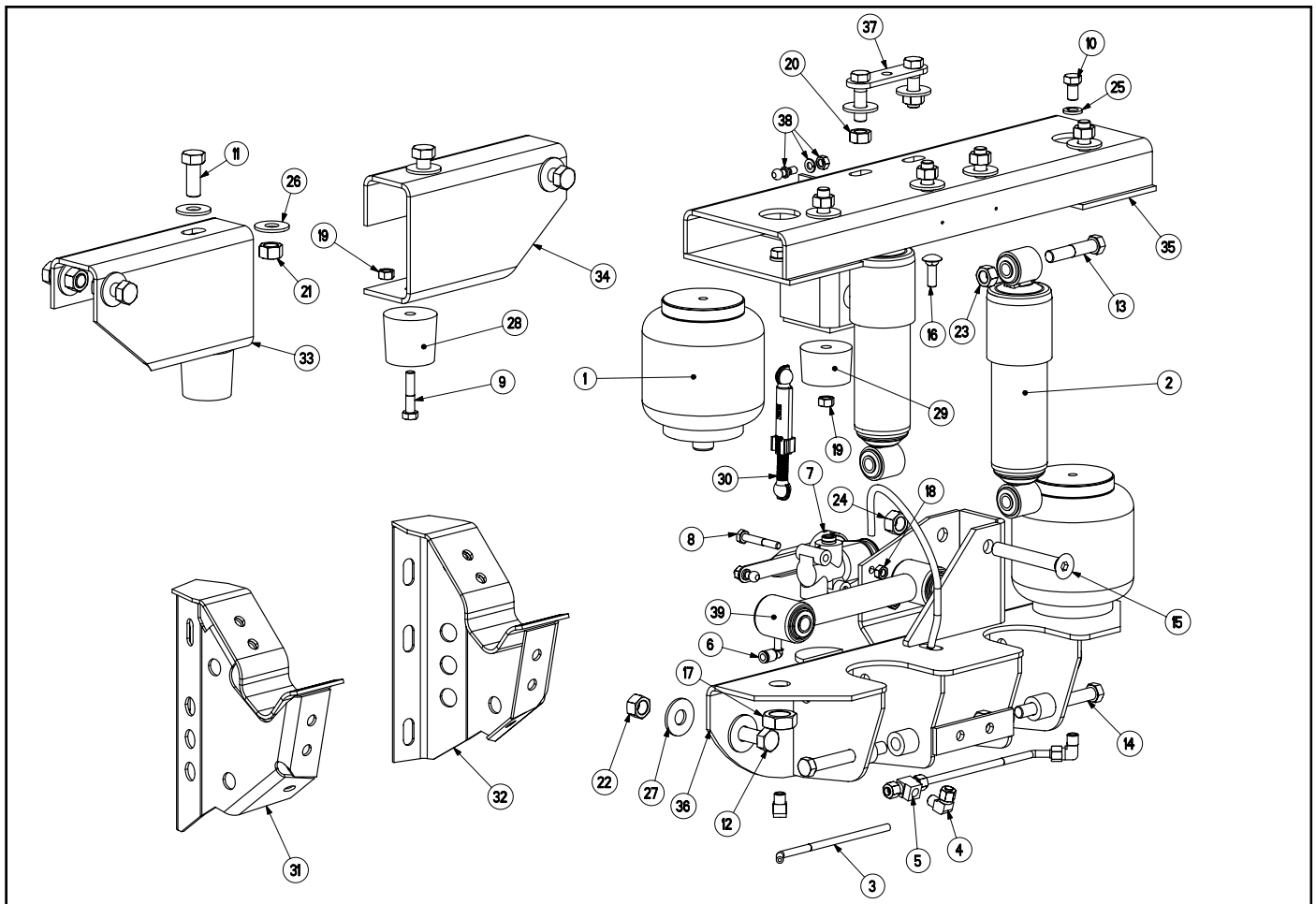

CABMATE® MODEL FRT106HD-A PARTS LIST

ITEM	PART NO.	DESCRIPTION	QTY	ITEM	PART NO.	DESCRIPTION	QTY
1	1102-0023	AIR SPRING	2	21	1476-1600	1/2 UNC HEX CENTER LOCK NUT (GRADE B)	6
2	1201-0054	SHOCK ABSORBER	2	22	1476-1601	1/2 UNC HEX CENTER LOCK NUT (GRADE C)	6
3	1302-0090	0.250 AIRLINE	2	23	1477-1400	7/16 UNF HEX CENTER LOCK NUT (GRADE B)	4
4	1302-1105	ELBOW, 1/4 TB 1/8 M-NPT	3	24	1477-1601	1/2 UNF HEX TOP LOCK NUT (GRADE C)	2
5	1302-1150	BRANCH TEE, 1/4 TB 1/8 F-NPT	1	25	1485-1200	3/8 LOCK WASHER	2
6	1302-5499	ELBOW, 1/4 TB 1/4 PTC, PUSH-IN DOT	1	26	1487-1400	7/16 TYPE A PLAIN WASHER	18
7	1350-0101	ASSEMBLY-HEIGHT CONTROL VALVE	1	27	1487-1600	1/2 TYPE A PLAIN WASHER	12
8	1401-0814	1/4 X 1 3/4 UNC HEX CAP SCREW (GRADE 5)	2	28	1500-0070	BUMPER-JOUNCE, 1.75	2
9	1401-1012	5/16 X 1 1/2 UNC HEX CAP SCREW (GRADE 5)	2	29	1500-0071	BUMPER-JOUNCE, 1.25	1
10	1401-1205	3/8 X 5/8 UNC HEX CAP SCREW (GRADE 5)	2	30	29910051	VALVE LINKAGE SERVICE KIT (15000213)	1
11	1401-1610	1/2 X 1 1/4 UNC HEX CAP SCREW (GRADE 5)	6	31	2265-4000	HOOD BRACKET-DRIVER	1
12	1402-1610	1/2 X 1 1/4 UNC HEX CAP SCREW (GRADE 8)	6	32	2265-5000	HOOD BRACKET-PASS	1
13	1403-1418	7/16 X 2 1/4 UNF HEX CAP SCREW (GRADE 5)	2	33	2265-6000	AUXILARY JOUNCE TRAVEL LIMITER-DRIVER	1
14	1403-1430	7/16 X 3 3/4 UNF HEX CAP SCREW (GRADE 5)	2	34	2265-7000	AUXILARY JOUNCE TRAVEL LIMITER-PASS	1
15	1420-1628	1/2 X 3 1/2 UNF SOC FLAT CSK HD CAP SCREW	2	35	2266-1100	BRACKET-MOUNT, CAB	1
16	1435-1008	5/16 X 1 UNC RND HD SQ NK BOLT (GRADE 5)	1	36	2266-2000	UNIT BOTTOM	1
17	1475-2400	3/4 UNF JAM NUT	2	37	2267-E000	STRAP-FASTENER, TOP	1
18	1476-0800	1/4 UNC HEX CENTER LOCK NUT (GRADE B)	2	38	2991-0026	KIT-BALL, PIVOT	2
19	1476-1000	5/16 UNC HEX CENTER LOCK NUT (GRADE B)	3	39	2993-2004	LATERAL CONTROL ROD	1
20	1476-1401	7/16 UNC HEX TOP LOCK NUT (GRADE C)	6	-	1350-0000	KIT-PROTECTION, PRESSURE	1