

# INSTALLATION INSTRUCTIONS

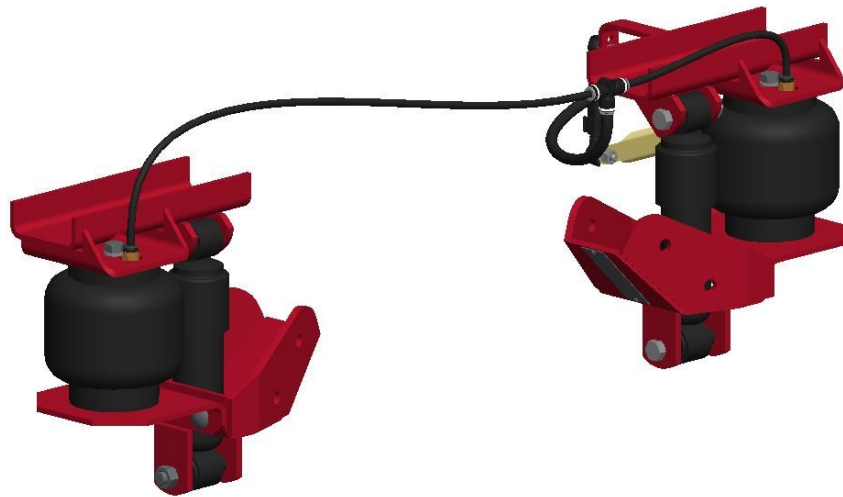

**FN89-A (2165-B000)**



The **CABMATE MODEL FN89-A** fits most of the following Ford Conventional Tractors:

LNT-800, 8000, 9000	LTS-8000, 9000
LN-800, 8000, 9000	LS-8000, 9000
LT-800, 8000, 9000	LTL-9000
L-800, 8000, 9000	LL-9000

It replaces the original rear cab supports Ford Part Nos. DOHZ-5A036-A and DOHZ-5A036-B, or DOHA-5N356-C and DOHA-5A356-E.

**This unit is not compatible with Tractors equipped with a horizontal muffler and vertical cab mounted exhaust.**

UNIT WEIGHT: 24.0 LB.

NET WEIGHT ADDED: 11.0 LB.

Link Mfg. Ltd.  
223 15th St. N.E.  
Sioux Center, IA USA  
51250-2120

(712) 722-4874

[www.linkmfg.com](http://www.linkmfg.com)

**QUESTIONS?  
CALL CUSTOMER  
SERVICE  
1-800-222-6283**

# CABMATE<sup>®</sup> MODEL FN89-A

Review the Parts List on page 3 to become familiar with the different components of the CABMATE.

**IMPORTANT:** Due to many chassis variables caused by installation of special equipment or options, the fit of the CABMATE FN89-A may be affected and should be evaluated before beginning installation.

**IMPORTANT:** Installation of the CABMATE system will allow the cab to move freely. Before starting installation, check clearances between the cab and any objects the cab may contact when it moves (1 1/2 inches of clearance should be sufficient). The clearance of components that are affected by cab movement, such as exhaust and radiator systems, must also be evaluated.

**INSTALLATION TIP:** Removal of shock absorber will allow the CABMATE to collapse further and may reduce installation time.

A. Remove the top mount bolts from the stock mounts. Securely prop up the cab and remove the rear cab supports. **NOTE:** SAVE ALL stock mount bolts for later use (Fig. 1)

B. Slide the unit halves of the CABMATE between the crossmember and the frame. Fasten the Unit Tops to the cab. Lower the cab to align the holes of the Unit Bottoms and the holes of the crossmember. Fasten the Unit Bottoms to the crossmember using the stock mount bolts. (Fig. 2)

C. Adjust the CABMATE to the Design Height (see Page 2). With the Isolator plates resting on the frame, tighten the 3/8 flange nuts (Part No. 14 on the parts list).

D. Determine the correct mounting position of the Unit Top Pivot Ball (part of Part No. 23 from the parts list). The Pivot Ball should be placed in the mount hole that will allow the valve arm to be approximately horizontal when the CABMATE is at Design Height. **SECURELY TIGHTEN ALL FASTENERS.** Lower the cab completely.

E. See page 2 for plumbing instructions and height adjustments.

F. **IMPORTANT:** After plumbing and height control adjustments are completed, temporarily adjust the CABMATE to its maximum upward position. There must be a minimum of 1/4" gap between the cab and the hood. Adjust the hood hinge forward as necessary (Fig. 3).

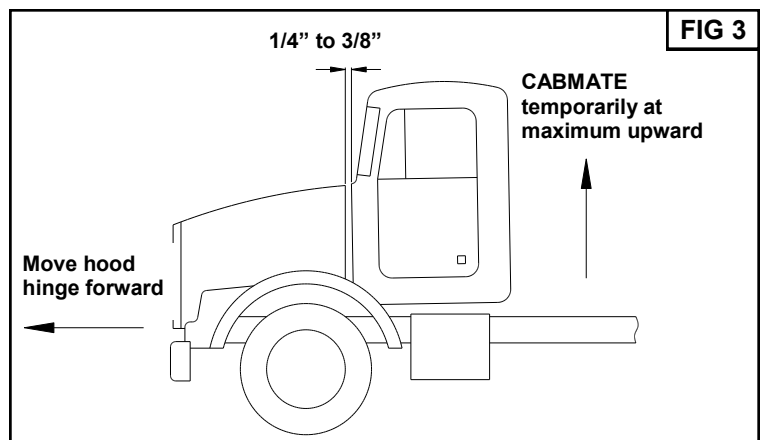
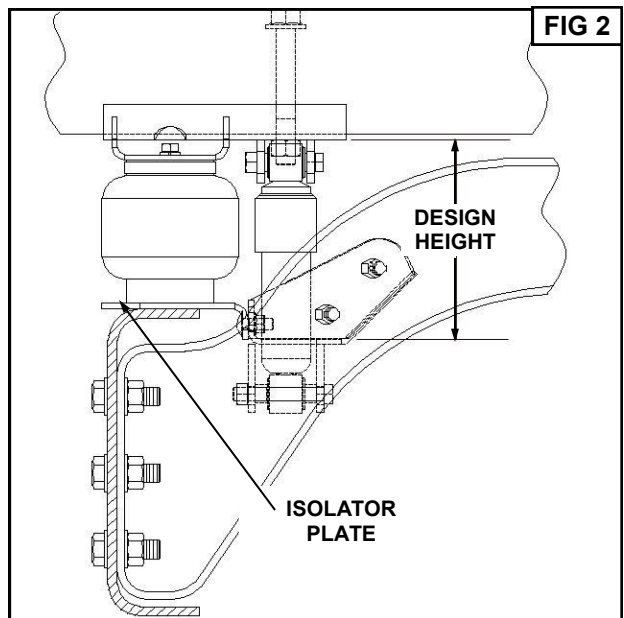
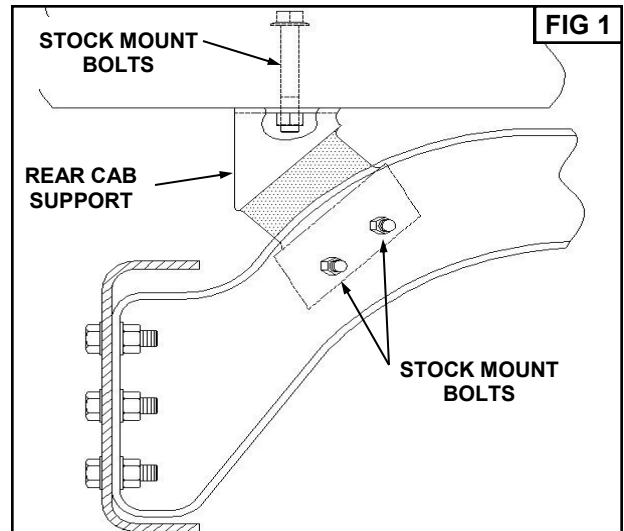

## PLUMBING INSTRUCTIONS



**WARNING: FOR SAFTY PURPOSES THE CABMATE MUST BE SUPPLIED FROM A PRESSURE PROTECTED CIRCUIT. IN THE EVENT OF AN AIR LEAK IN THE CAB SUSPENSION, FAILURE TO PROVIDE A PRESSURE PROTECTED CIRCUIT MAY CAUSE LOSS OF AIR PRESSURE TO VITAL SYSTEMS ON THE VEHICLE.**

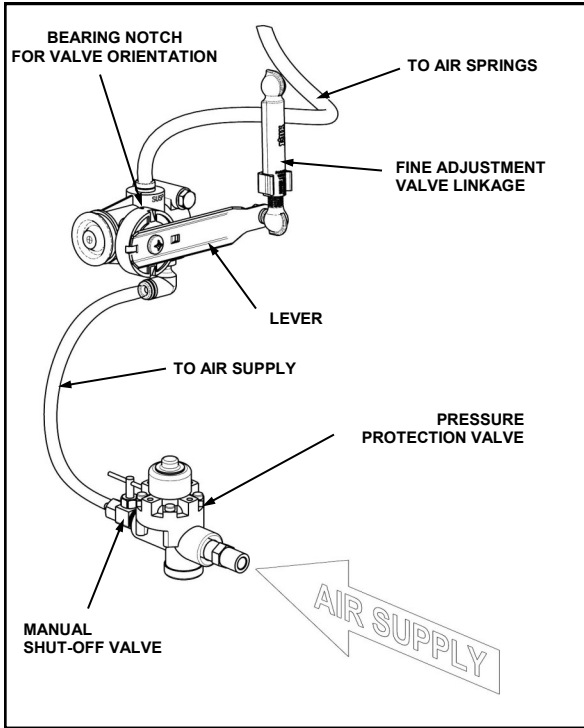

**WARNING: LOSS OR APPLICATION OF AIR PRESSURE TO CABMATE WILL CAUSE SUDDEN MOVEMENT OF THE CAB. PRIOR TO INSTALLING OR PERFORMING ANY MAINTENANCE, BLOCK UP THE CABMATE TO PREVENT THE POSSIBILITY OF INJURY.**



**WARNING: CONNECT THE CABMATE DIRECTLY TO THE MAIN AIR TANK. YOU WILL NEED AN AIR PRESSURE PROTECTION VALVE IN THE LINE. (INCLUDED IN THE PRESSURE PROTECTION KIT. LINK MFG. PART NO. 1350-0000). DO NOT USE AN AIR PRESSURE REGULATOR!**

- A. With the tank at 0 p.s.i., remove the existing plug or fitting from the desired port.
- B. Apply joint compound to the fittings and install the pressure protection kit. **DO NOT USE TEFLON TAPE.** Be sure that the arrows on the valve are pointing in the direction of air flow and the vent hole is pointed down. NOTE: Additional fittings/reducers may be required to attach the hex nipple to the main air tank.
- C. Run the 1/4" airline from the shut-off valve to the CABMATE. Be sure that the airline has enough clearance so that there are no pinch points that may restrict or cut the airline. Secure the airline using the cable ties supplied by Link Mfg.
- D. Tighten all plumbing fittings. Then, with the system at operating pressure (90 to 110 p.s.i.), open the Manual Shut-off Valve to supply air to the CABMATE. Check the system for air leaks.

E. Check for proper operation of the height control valve. Disconnect the valve linkage from the lever. Push the lever **down** 45°, air should flow into the

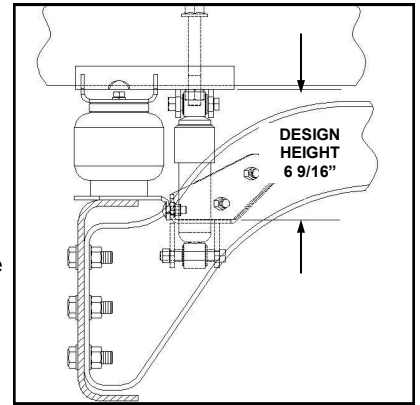

air spring(s). Return the lever to the neutral position. Push the lever **up** 45°, air should exhaust from the air spring(s). Return the lever to the neutral position; no air should flow. Reconnect the valve linkage to the lever.

### HEIGHT ADJUSTMENTS

Measure the design height of the air spring(s). The height should be **6 9/16** inches ± 1/16. To change the height, disconnect one end of the valve linkage and adjust accordingly. Tighten the lock nuts on the valve linkage.

### MAINTENANCE

CABMATES need no lubrication and little maintenance. The following components should be checked at the time the truck is being serviced. However, immediate corrective action should be taken if a serious malfunction occurs.

COMPONENT	POSSIBLE PROBLEM	CORRECTIVE ACTION	TORQUE
<b>Airlines</b>	Air leaks	Replace airline	<b>Compression Nut</b> Hand Tight + 1 Turn
<b>Fittings</b>	Air leaks	Remove fitting and apply fresh joint compound. Reinstall fitting, but <b>Do Not Overtighten. Do not use teflon tape.</b>	<b>Threaded into:</b> <b>Metal Plastic</b> 15 Hand Tight Ft. Lbs. + 1 Turn
<b>Air Springs</b>	<b>A.</b> Improper height <b>B.</b> Air leakage	<b>A.</b> Adjust valve linkage to maintain proper air spring height. <b>B.</b> Replace air spring.	<b>Size Metal Plastic</b> <b>3/8</b> 25 Ft. Lbs 04 Ft. Lbs <b>1/2</b> 28 Ft. Lbs 10 Ft. Lbs <b>3/4</b> 30 Ft. Lbs 10 Ft. Lbs
<b>Height Control Valve</b>	Air spring(s) will not inflate when weight is added to the cab; <b>OR</b> Air spring(s) will not deflate when weight is removed from the cab.	<b>A.</b> Inspect valve to insure drive bearing notch is located on " <b>SUSP/SUPPLY</b> " port side of valve. If not, loosen lever screw (but do not remove completely) and pull lever loose from drive bearing, rotate drive bearing until the bearing notch is in the correct position and resecure lever by tightening lever screw. <b>B.</b> Replace Valve	<b>1/4 Mount Fasteners</b> 10 Ft. Lbs. <b>Bearing Screw</b> 40-50 InLbs.
<b>Shock Absorber</b>	Insufficient dampening effect	Replace shocks	45 Ft. Lbs.
<b>Lateral Control Rod</b>	<b>A.</b> Loose nuts on lateral control rod bolts <b>B.</b> Worn bushings.	<b>A.</b> Tighten securely to clamp the inner sleeve. <b>B.</b> Replace lateral control rod.	40 Ft. Lbs.



**IMPORTANT:** Periodically check the tightness of all fasteners.

110425  
CV600A

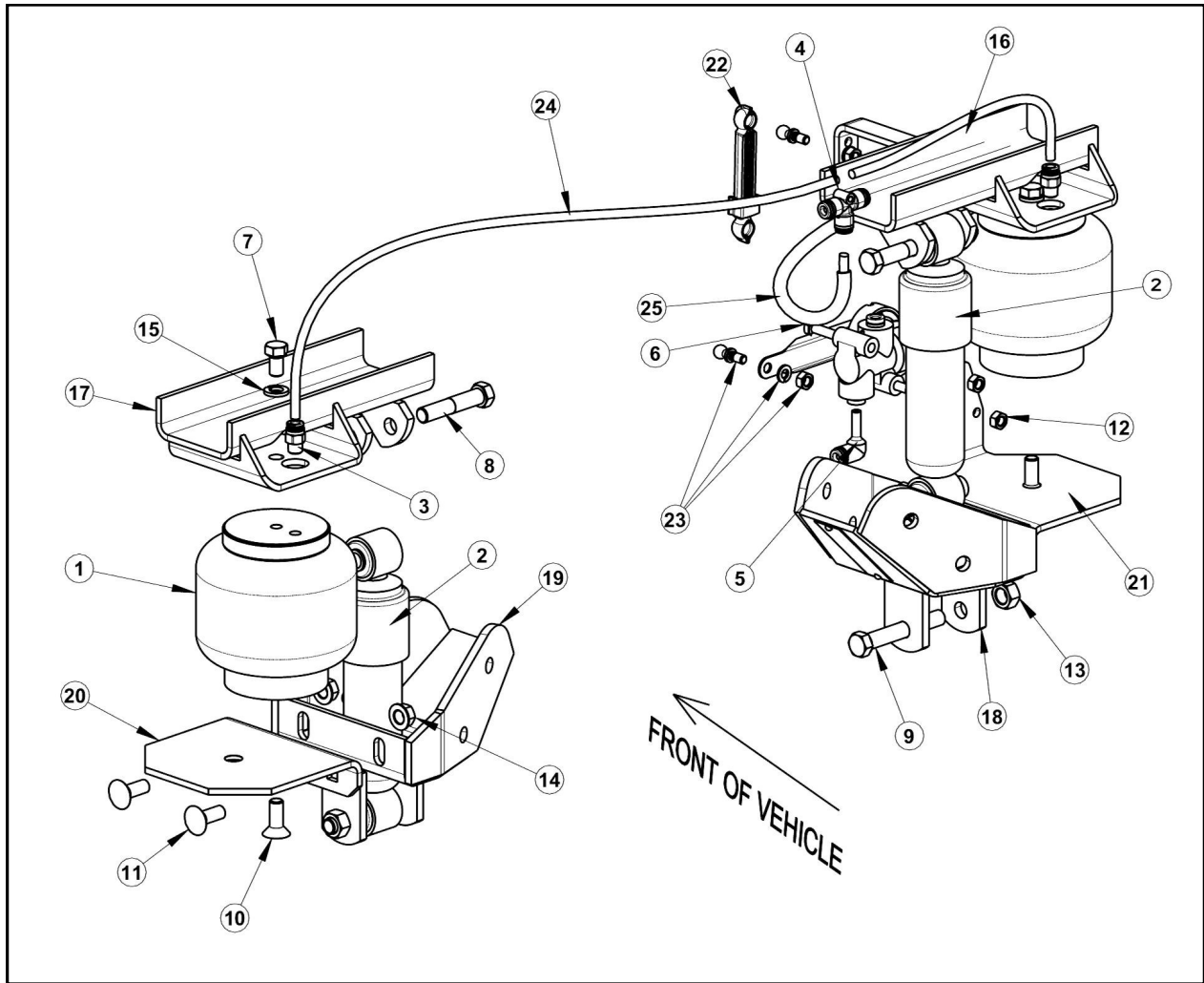

## CABMATE® MODEL FN89-A PARTS LIST

ITEM	PART NO.	DESCRIPTION	QTY	ITEM	PART NO.	DESCRIPTION	QTY
1	1102-0022	SPRING-AIR	2	14	1480-1200	3/8 UNC SERRATED FLANGE NUT	4
2	1201-0012	SHOCK ABSORBER	2	15	1485-1200	3/8 LOCK WASHER	2
3	13025201	CONNECTOR, 1/4 TB 1/8 M-NPT	2	16	2165-1000	UNIT TOP-PASSENGER	1
4	13025205	UNION TEE, 1/4 TB	1	17	2165-2000	UNIT TOP-DRIVER	1
5	13025499	ELBOW-PLUG-IN, 1/4"	1	18	2165-3000	UNIT BOTTOM-PASSENGER	1
6	1401-0814	1/4 X 1 3/4 UNC HEX CAP SCR (GR 5)	2	19	2165-4000	UNIT BOTTOM-DRIVER	1
7	1401-1205	3/8 X 5/8 UNC HEX CAP SCR (GR 5)	2	20	2165-5001	BOTTOM ISOLATOR BRACKET	1
8	1403-1418	7/16 X 2 1/4 UNF HEX CAP SCR (GR 5)	2	21	21655100	BOTTOM ISOLATOR BRACKET	1
9	1403-1424	7/16 X 3 UNF HEX CAP SCR (GR 5)	2	22	29910051	SERVICE KIT-LINKAGE, MEDIUM	1
10	1417-1208	3/8 X 1 UNC SOC FLAT CSK HD CAP SCREW	2	23	2991-0026	KIT-PIVOT BALL	2
11	1435-1208	3/8 X 1 UNC RND HD SQ NK BOLT (GRADE 5)	4	24	1302-0090	AIRLINE-NYLON, .250 O.D., BULK	1
12	1476-0800	1/4 UNC HEX CTR LOCK NUT (GR B)	2	25	1500-0435	LOOM-CORRUGATED, .250, BULK	1
13	1477-1400	7/16 UNF HEX CTR LOCK NUT (GR B)	4	-	1350-0000	KIT-PROTECTION, PRESSURE	1
14	1476-0800	1/4 UNC HEX CENTER LOCK NUT (GRADE B)	2				