

ROI Cabmate®
Cab Suspension

LINK®

Link Mfg. Ltd.
223 15th St. N.E.
Sioux Center, IA USA
51250-2120
www.linkmfg.com

**QUESTIONS?
CALL CUSTOMER
SERVICE
1-800-222-6283**

OWNER'S GUIDE

Cab Suspension

PACCAR

PETERBILT 567 / 579

KENWORTH T680 / T880 / W990

SLEEPER CABS

MODEL YEAR 2012 & NEWER

LINK PART NO.
26302030



1. PLUMBING INSTRUCTIONS

⚠️WARNING FOR SAFETY PURPOSES THE ROI CABMATE MUST BE SUPPLIED FROM A PRESSURE PROTECTED CIRCUIT. IN THE EVENT OF AN AIR LEAK IN THE CAB SUSPENSION, FAILURE TO PROVIDE A PRESSURE PROTECTED CIRCUIT MAY CAUSE LOSS OF AIR PRESSURE TO VITAL SYSTEMS ON THE VEHICLE.

⚠️WARNING CONNECT THE ROI CABMATE DIRECTLY TO THE MAIN AIR TANK. YOU WILL NEED AN AIR PRESSURE PROTECTION VALVE IN THE LINE. (INCLUDED IN THE PRESSURE PROTECTION KIT. LINK MFG. PART NO. 13500000). DO NOT USE AN AIR PRESSURE REGULATOR!

HEIGHT ADJUSTMENTS

Measure the design height of the air spring(s). The height should be 5.25 inches. To change the height, disconnect one end of the valve linkage and adjust accordingly. Tighten the lock nuts on the valve linkage.

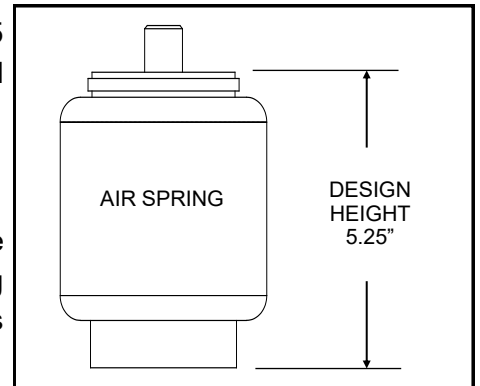

MAINTENANCE

The ROI CABMATE needs no lubrication and little maintenance. The following components should be checked at the time the truck is being serviced. However, immediate corrective action should be taken if a serious malfunction occurs.

COMPONENT	POSSIBLE PROBLEM	CORRECTIVE ACTION
Airlines	Air leaks	Replace airline
Fittings	Air leaks	Replace fittings.
Air Springs	A. Improper height B. Air leakage C. Air springs not filling	A. Adjust valve linkage to maintain proper air spring height. B. Replace air spring. C. See "Electronic Troubleshooting" Section.
Control Box	Air spring(s) will not inflate when weight is added to the cab; OR Air spring(s) will not deflate when weight is removed from the cab.	See "Electronic Troubleshooting" Section.
Shock Absorber	Improper damping effect	A. Inspect LED for fault codes. If present, repair per "Electronic Troubleshooting" section. B. If no faults are present, replace shocks.

⚠️WARNING LOSS OF AIR PRESSURE TO THE ROI CABMATE WILL CAUSE SUDDEN MOVEMENT OF THE CAB. PRIOR TO INSTALLING OR PERFORMING MAINTENANCE, BLOCK UP THE CABMATE TO PREVENT THE POSSIBILITY OF INJURY.

Prior to removing the control box for servicing, perform the following:

1. Unplug the power harness
2. Unplug the shock harness
3. Unplug the airlines from the control box
4. Disconnect the position sensor

2. TORQUE INSTRUCTIONS

IMPORTANT: Periodically check the tightness of all fasteners.

TORQUE TABLE		
COMPONENT	FASTENER	TORQUE
POSITION SENSOR	M5	26-44 IN-LBS
CONTROL BOX	1/4	48-60 IN-LBS
SHOCKS	1/2	60-70 FT-LBS

3. FAULT TROUBLESHOOTING FLOW CHART

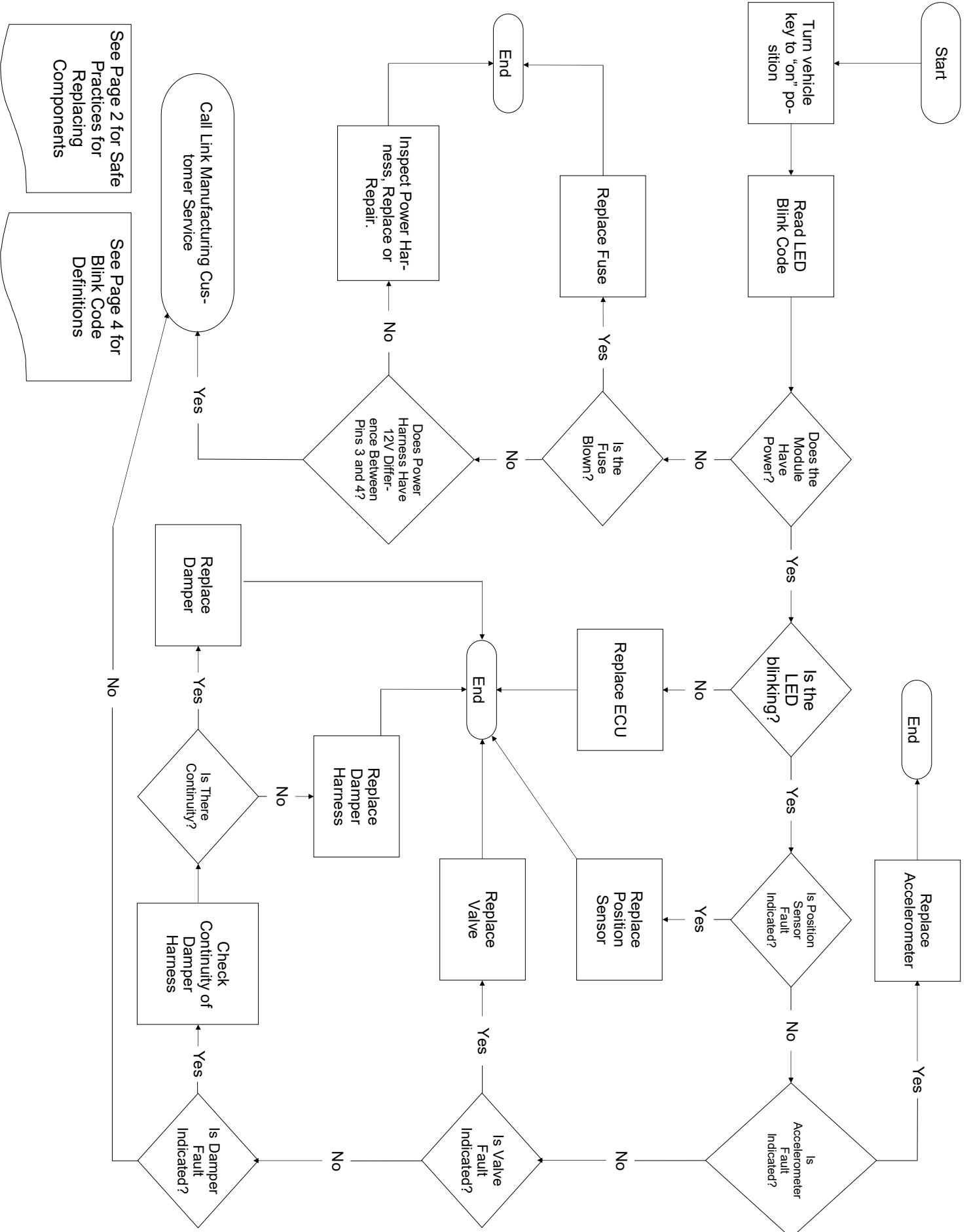

4. BLINK CODE FLOW CHART AND TABLE

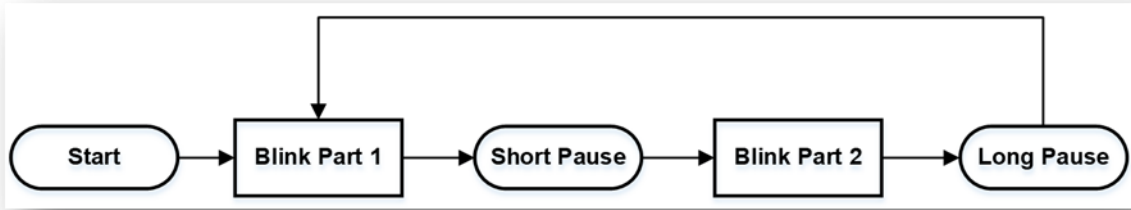

Blink Code		Fault Definition	
Blink Part 1	Blink Part 2	Component	Description
1	2	Position Sensor	Low Voltage
1	3	Position Sensor	High Voltage
5	1	Fill Valve	Open Circuit
5	2	Fill Valve	Short to Ground
5	3	Fill Valve	Short to Battery
5	4	Fill Valve	Over Current
6	1	Exhaust Valve	Open Circuit
6	2	Exhaust Valve	Short to Ground
6	3	Exhaust Valve	Short to Battery
6	4	Exhaust Valve	Over Current
2	3	Accelerometer	Low Voltage
2	4	Accelerometer	High Voltage
3	1	PS Damper	Open Circuit
3	2	PS Damper	Short to Ground
3	4	PS Damper	Short to Battery
3	5	PS Damper	Over Current
4	1	DS Damper	Open Circuit
4	2	DS Damper	Short to Ground
4	3	DS Damper	Short to Battery
4	5	DS Damper	Over Current
LED on, no blinking		ECU	Unknown Failure
Steady, slow blinking		No faults detected	

6. **WARRANTY** - Refer to www.ROIcabmate.com for warranty information and registration.

7. **SERVICE KITS**

ROI CABMATE - PACCAR	
ITEM NUMBER	DESCRIPTION
4CM00049	SERVICE KIT - ROI CONTROL MODULE
4CM00051	SERVICE KIT - WIRING HARNESS, SHOCKS
4CM00052	SERVICE KIT - WIRING HARNESS, POWER
4CM00054	SERVICE KIT - WIRING HARNESS AND FASTENERS, CONTROL MODULE
4CM00055	SERVICE KIT - AIRLINES WITH VALVES AND FITTINGS
4CM00056	SERVICE KIT - POSITION SENSOR, PIVOT BALL AND FASTENERS
4CM00057	SERVICE KIT -ACCELEROMETER WITH FASTENERS
4CM00058	SERVICE KIT - PIVOT BALL CLAMP WITH PIVOT BALLS
4CM00061	SERVICE KIT - ECU
4CM00065	SERVICE KIT - ROI SHOCK ABSORBER ASSEMBLY
4CM00072	SERVICE KIT - CAB BRACKET
4CM00073	SERVICE KIT - SUPPORT BRACKET
4CM00074	SERVICE KIT - HEIGHT CONTROL SENSOR BRACKET
4CM00075	SERVICE KIT - POSITION SENSOR BRACKET
4CM00081	SERVICE KIT - CONTROL BOX BRACKETS AND FASTENERS
29910050	SERVICE KIT - LINKAGE, SHORT

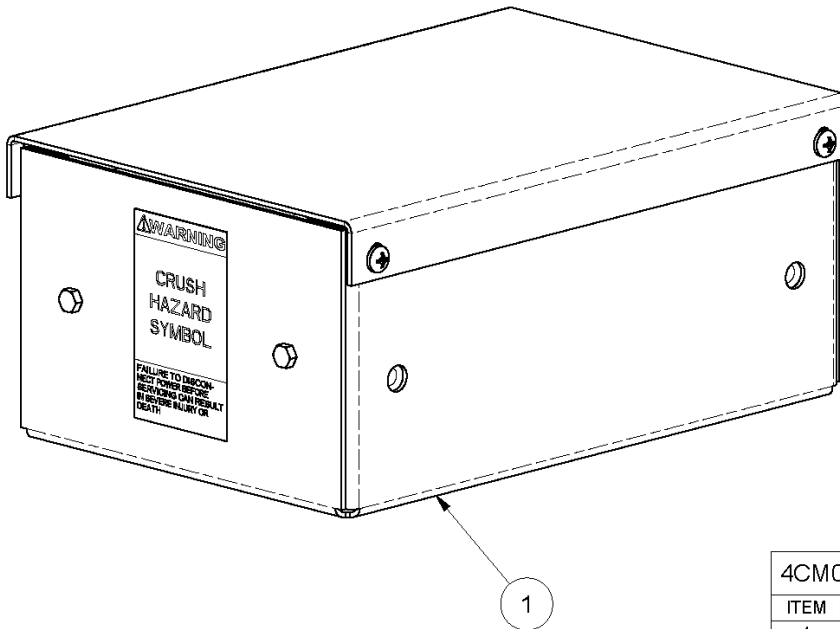

4CM00049 - SERVICE KIT - ROI CONTROL MODULE		
ITEM	DESCRIPTION	QTY
1	ECU BOX, PB 579, KW T680	1

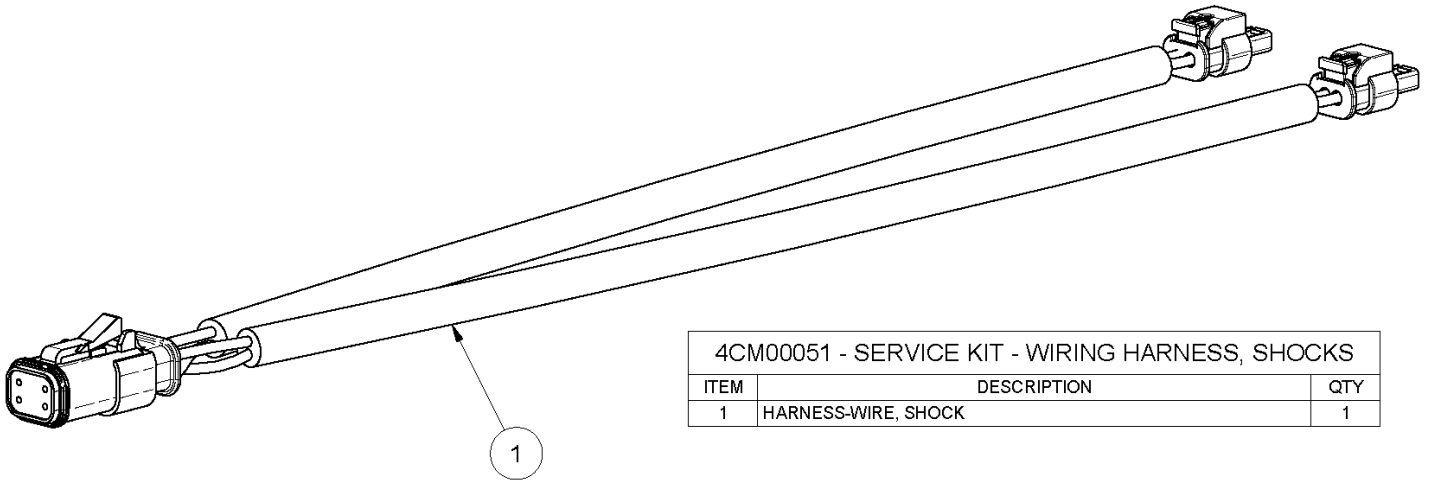

4CM00051 - SERVICE KIT - WIRING HARNESS, SHOCKS		
ITEM	DESCRIPTION	QTY
1	HARNESS-WIRE, SHOCK	1

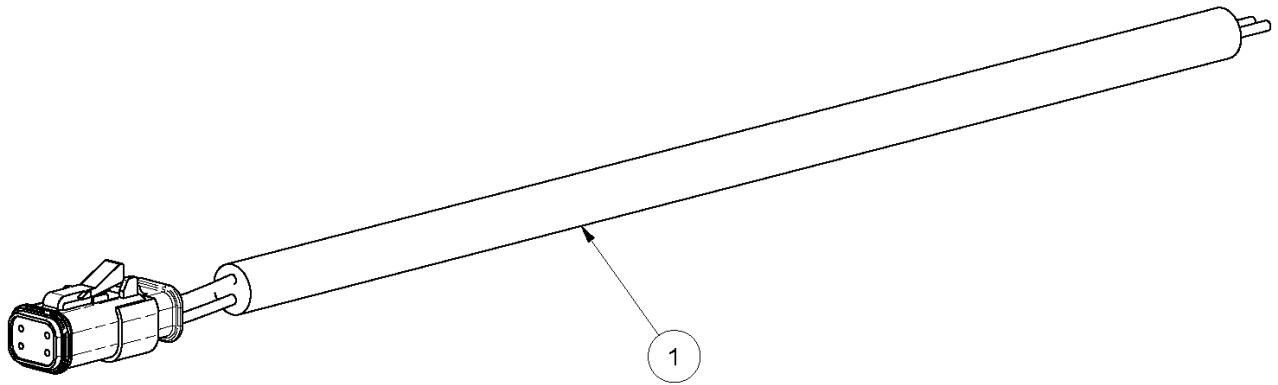

4CM00052 - SERVICE KIT - WIRING HARNESS, POWER		
ITEM	DESCRIPTION	QTY
1	HARNESS-WIRE, POWER	1

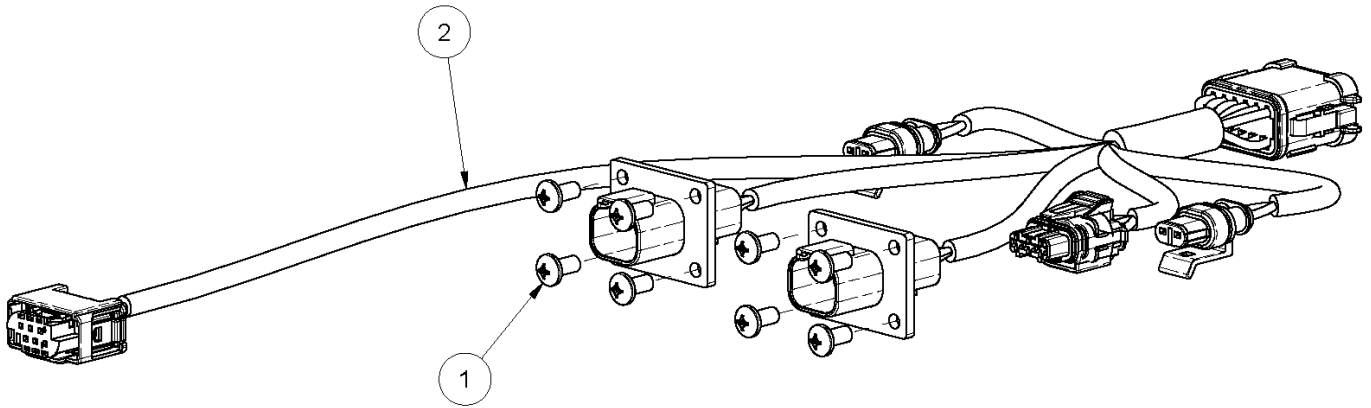

4CM00054 - SERVICE KIT - WIRING HARNESS AND FASTENERS, CONTROL MODULE		
ITEM	DESCRIPTION	QTY
1	#10 X 3/8 THREAD CUTTING SCREW	8
2	HARNESS-WIRE, CONTROL BOX	1

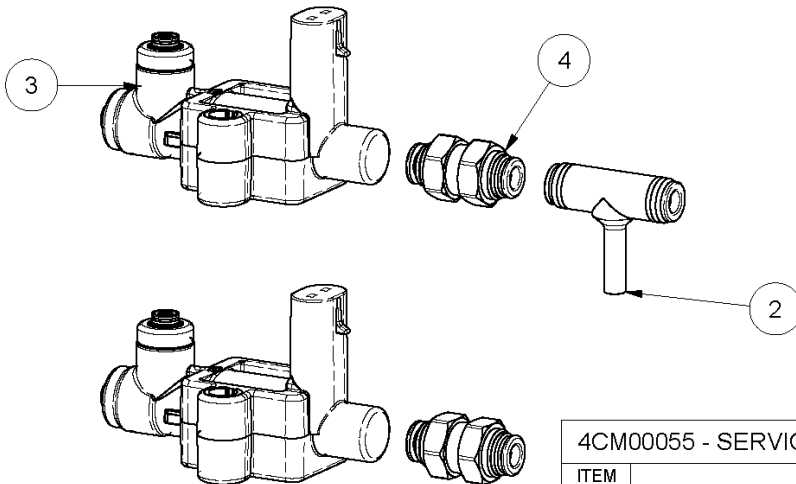

4CM00055 - SERVICE KIT - AIRLINES WITH VALVES AND FITTINGS		
ITEM	DESCRIPTION	QTY
1	AIRLINE-NYLON, .250 O.D., BULK (FEET)	2
2	BRANCH TEE-PLUG-IN, 1/4"	1
3	SOLENOID-VALVE	2
4	UNION-BULKHEAD, 1/4" TB	2

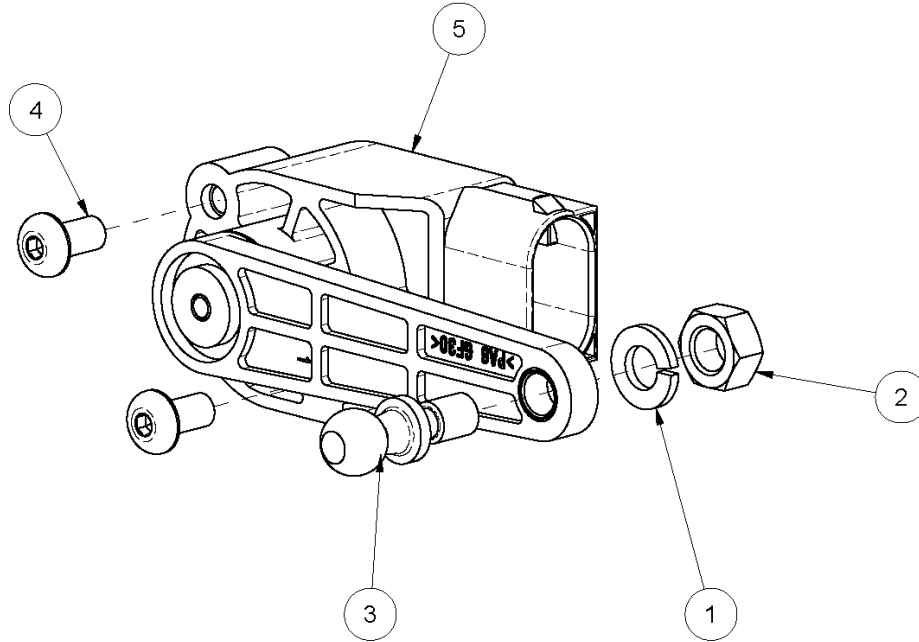

4CM00056 - SERVICE KIT - POSITION SENSOR, PIVOT BALL AND FASTENERS		
ITEM	DESCRIPTION	QTY
1	1/4 LOCK WASHER	1
2	1/4 UNC HEX NUT (GR B)	1
3	BALL-PIVOT, THREADED	1
4	M5X0.8X10 SOCKET BUTTON HD SS CAP SCREW	2
5	SENSOR-POSITION	1

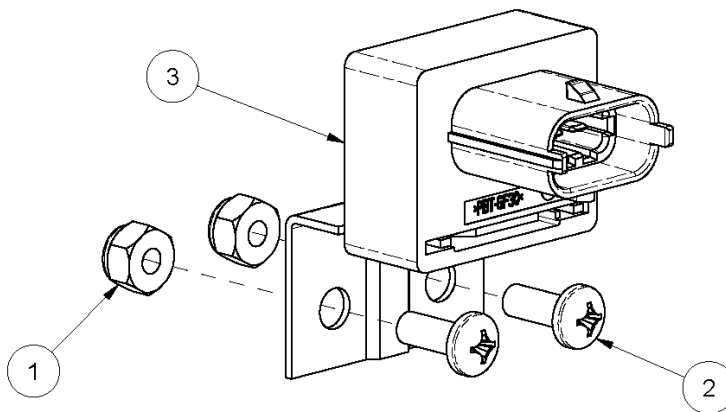

4CM00057 - SERVICE KIT -ACCELEROMETER WITH FASTENERS		
ITEM	DESCRIPTION	QTY
1	10-24 NYLOCK NUT, SS	2
2	10-24 x 1/2 UNC CR PH MACH SCREW, SS	2
3	ZF ACCELEROMETER ASSEMBLY	1

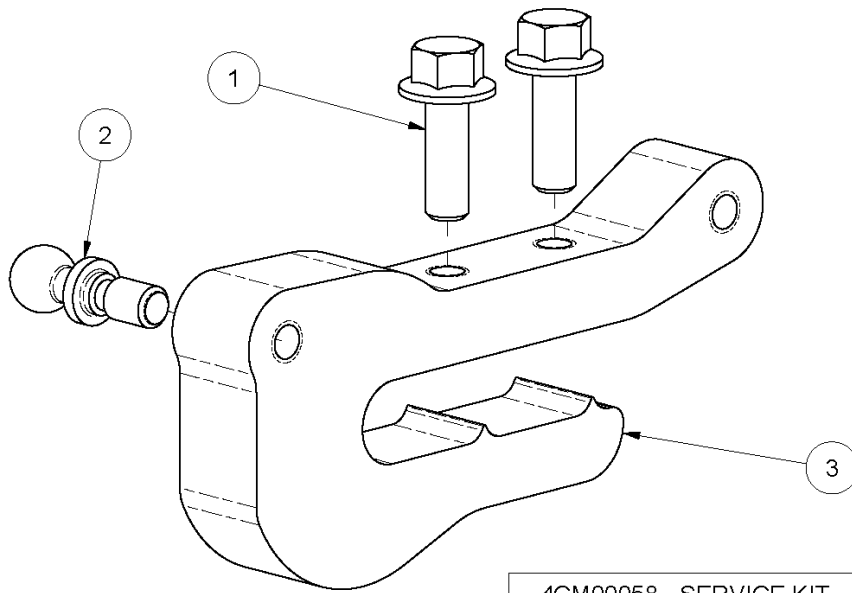

4CM00058 - SERVICE KIT - PIVOT BALL CLAMP WITH PIVOT BALLS

ITEM	DESCRIPTION	QTY
1	1/4 X 3/4 FLANGE HEAD BOLT	2
2	BALL-PIVOT, THREADED	2
3	CLAMP-PIVOT BALL	1

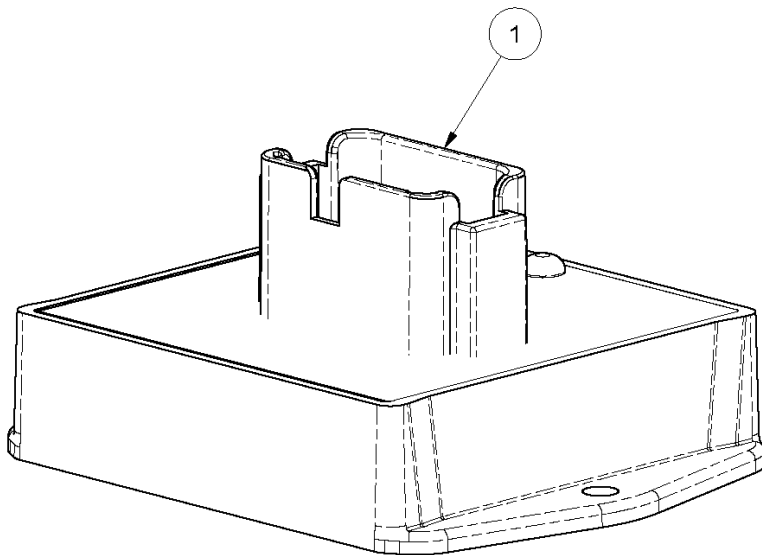

4CM00061 - SERVICE KIT - ECU

ITEM	DESCRIPTION	QTY
1	CL449 CONTROLLER, PB 579, KW T680	1

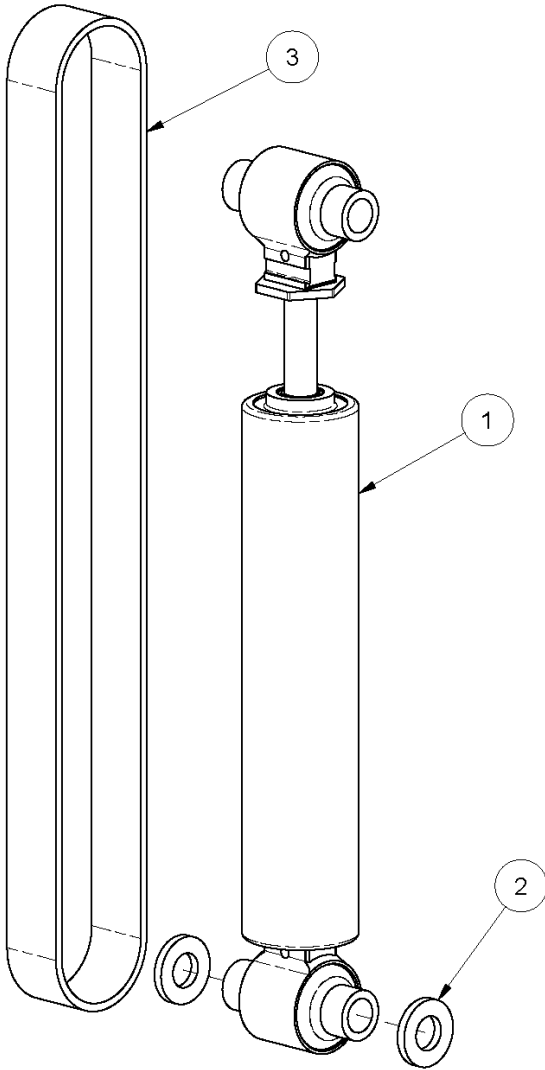

4CM00065 - SERVICE KIT - SHOCK ABSORBER ASSEMBLY		
ITEM	DESCRIPTION	QTY
1	SHOCK ABSORBER	1
2	SPACER	2
3	STRAP-RETENTION	1

4CM00072 - SERVICE KIT - CAB BRACKET		
ITEM	DESCRIPTION	QTY
1	BRACKET CAB	1

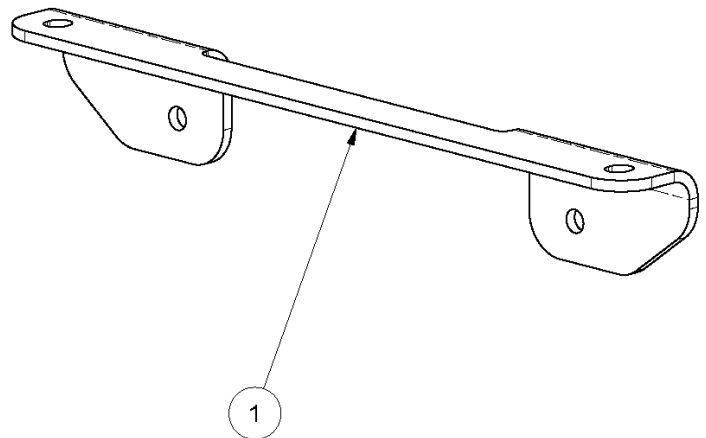

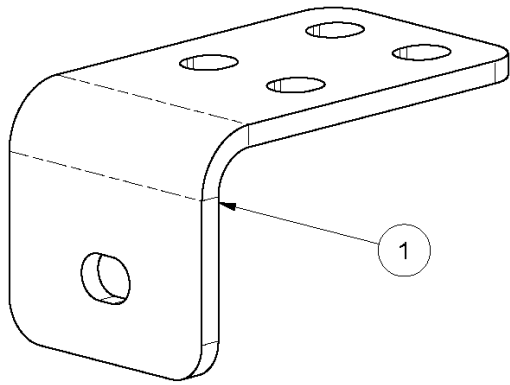

4CM00073 - SERVICE KIT - SUPPORT BRACKET		
ITEM	DESCRIPTION	QTY
1	BRACKET-SUPPORT	1

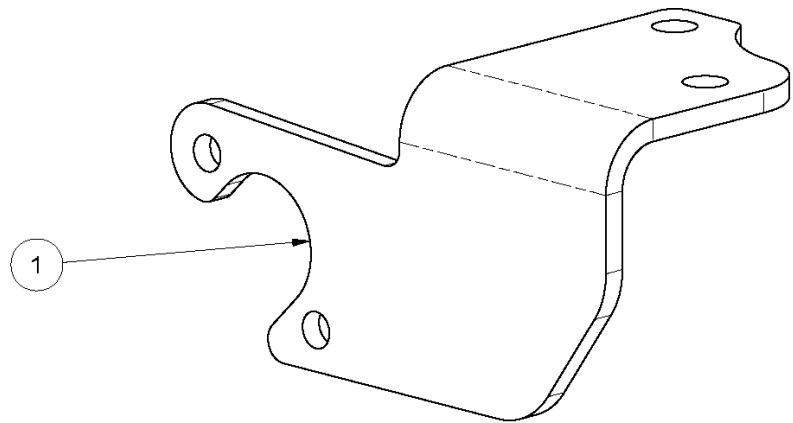

4CM00074 - SERVICE KIT - HEIGHT CONTROL SENSOR BRACKET		
ITEM	DESCRIPTION	QTY
1	BRACKET HEIGHT CONTROL SENSOR	1

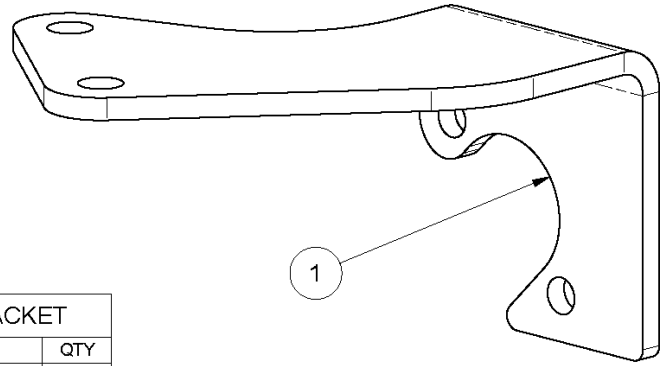

4CM00075 - SERVICE KIT - POSITION SENSOR BRACKET		
ITEM	DESCRIPTION	QTY
1	BRACKET-POSITION SENSOR	1

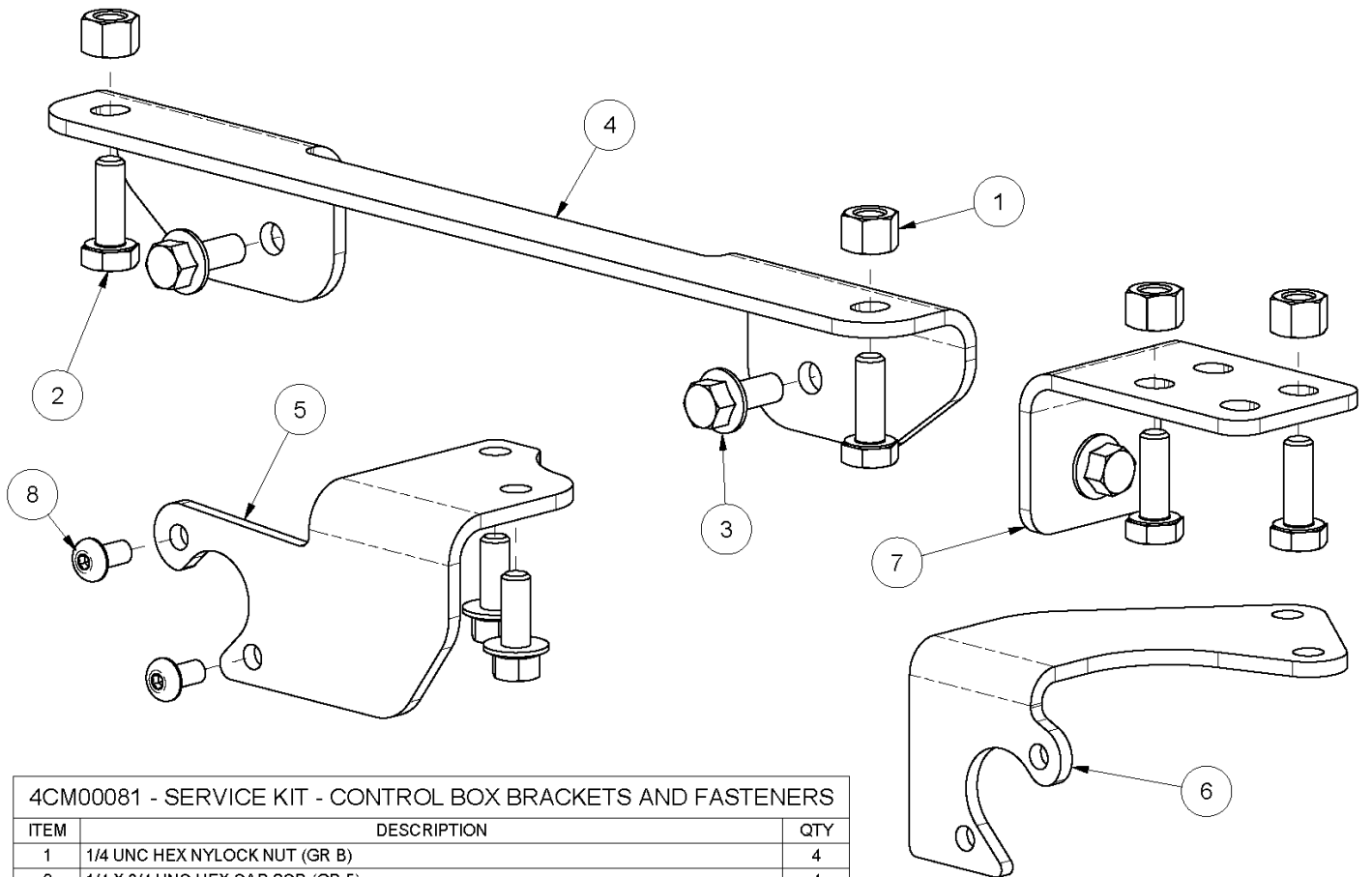

4CM00081 - SERVICE KIT - CONTROL BOX BRACKETS AND FASTENERS		
ITEM	DESCRIPTION	QTY
1	1/4 UNC HEX NYLOCK NUT (GR B)	4
2	1/4 X 3/4 UNC HEX CAP SCR (GR 5)	4
3	1/4 X 5/8 FLANGE HEAD BOLT	5
4	BRACKET CAB	1
5	BRACKET HEIGHT CONTROL SENSOR	1
6	BRACKET-POSITION SENSOR	1
7	BRACKET-SUPPORT	1
8	M5X0.8X10 SOCKET BUTTON HD SS CAP SCREW	2

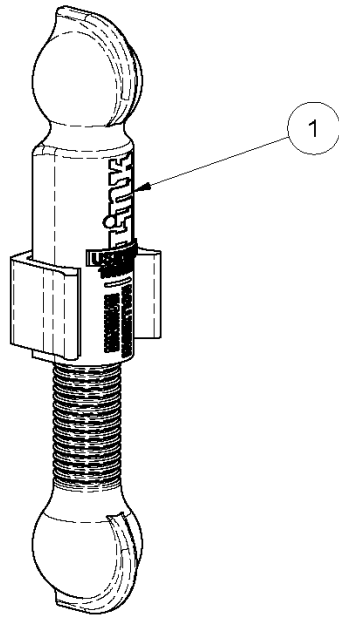

29910050 - SERVICE KIT-LINKAGE,SHORT		
ITEM	DESCRIPTION	QTY
1	LINKAGE-VALVE	1



LINK MANUFACTURING, LTD.
223 15TH ST. NE, SIOUX CENTER, IA 51250
1-800-222-6283 www.linkmfg.com