

ROI Cabmate®
Cab Suspension

LINK®

Link Mfg. Ltd.
223 15th St. N.E.
Sioux Center, IA USA
51250-2120
www.linkmfg.com

**QUESTIONS?
CALL CUSTOMER
SERVICE
1-800-222-6283**

INSTALLATION INSTRUCTIONS

Cab Suspension

**VOLVO
VNL & VNR SERIES
MODEL YEAR 2017 & NEWER**

**LINK PART NO.
26302040**

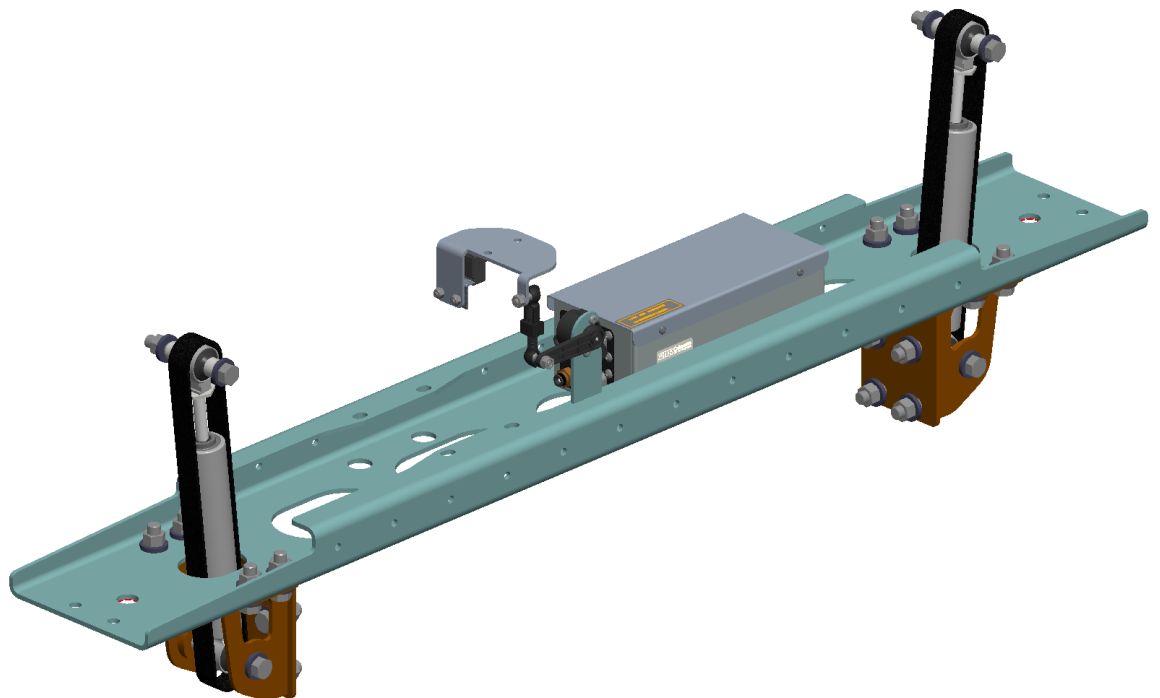

IMPORTANT: IT IS IMPORTANT THAT THE ENTIRE INSTALLATION INSTRUCTIONS BE READ THOROUGHLY BEFORE PROCEEDING WITH SUSPENSION INSTALLATION.





1. INTRODUCTION

Thank you for choosing a Link ROI CabMate Suspension. We want to help you get the best results from this suspension and to operate it safely. This manual contains information to introduce you to the Link ROI CabMate Suspension and to assist you with its installation. This manual is intended solely for use with this product.

All information in this manual is based on the latest information available at the time of printing. Link Manufacturing reserves the right to change its products or manuals at any time without notice.

Damaged components should be returned to Link with a pre-arranged Returned Materials Authorization (RMA) number through the Customer Service Department. The damaged component may then be replaced if in compliance with warranty conditions.

2. SAFETY SYMBOLS, TORQUE SYMBOL, and NOTES

	DANGER indicates a hazardous situation which if not avoided, will result in death or serious injury.
	WARNING indicates a potentially hazardous situation which, if not avoided, could result in death or serious injury.
	CAUTION indicates a potentially hazardous situation which, if not avoided, could result in minor or moderate injury.
	NOTICE indicates a potentially hazardous situation which, if not avoided, may result in property damage.
	TORQUE indicates named fasteners are to be tightened to a specified torque value.
NOTE:	A Note provides information or suggestions that help you correctly perform a task.

3. SAFE WORKING PRACTICES:

3.1 CAUTION

When handling parts, wear appropriate gloves, eyeglasses, ear protection, and other safety equipment.

3.2 CAUTION

Practice safe lifting procedures. Consider size, shape, and weight of assemblies. Obtain help or the assistance of a crane when lifting heavy assemblies. Make certain the path of travel is clear.

4. INSTALLATION GUIDELINES

4.1 In order for this CabMate suspension to operate properly, it must operate in the parameters specified by Link.

4.2 No alterations of any Link CabMate suspension component is permitted without proper authorization from qualified Link personnel.

4.3 No welding of any suspension components is permitted except when specified by Link.

4.4 CAUTION

The vehicle manufacturer should be consulted before any modifications are made to the frame of the vehicle. Cutting or altering the frame in certain areas may affect the manufacturer's warranty.

4.5 CAUTION

Proper tightening of fasteners is important to the performance and safety of the suspension. Follow all torque specifications throughout the instructions. Refer to manufacturer's torque specifications when reinstalling any original fasteners.

5. PREP VEHICLE FOR ROI CABMATE INSTALLATION (PRE-INSTALL STEPS)



WARNING

To prevent injury from compressed air and unintended cab motion, do not connect the cab suspension to the air source until the cab suspension is completely assembled and you have read and understood the owners manual.

Tools Required

- Pliers
- Airline cutting tool
- Metric socket set
- Metric wrench set
- Standard socket set
- Standard wrench set
- Torque wrench
- Hex key: 3mm

5.1

Measure the distance between the air spring mounting surfaces. Record this measurement. When the installation is complete the distance will be measured again to verify the air spring height has not changed (**FIG.1**).

5.2

Remove the fairings over the fuel tanks to increase access to the cab suspension.

5.3

Jack up the cab between the driver's side frame rail and rear of cab.

5.4

Disconnect airlines from the air springs and the height control valve.

5.5

Verify the cab is fully supported.

5.6

Verify the vehicle is off and remove the key to prevent others from starting the vehicle.

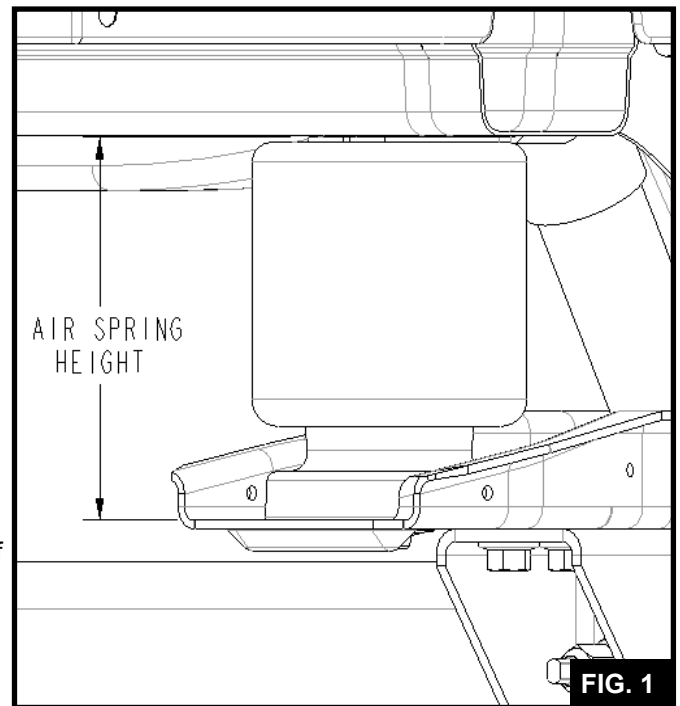

6. REMOVE EXISTING CAB SUSPENSION PARTS

WARNING

Failure to have rear of the cab fully supported will cause motion of the rear of the cab, which may result in operator injury. See section 5 for instructions on supporting the rear of the cab.

6.1

Starting on the passenger side of the truck, remove the lower and upper shock mount bolts and nuts. These parts are not reused and may be discarded (**FIG.2**).

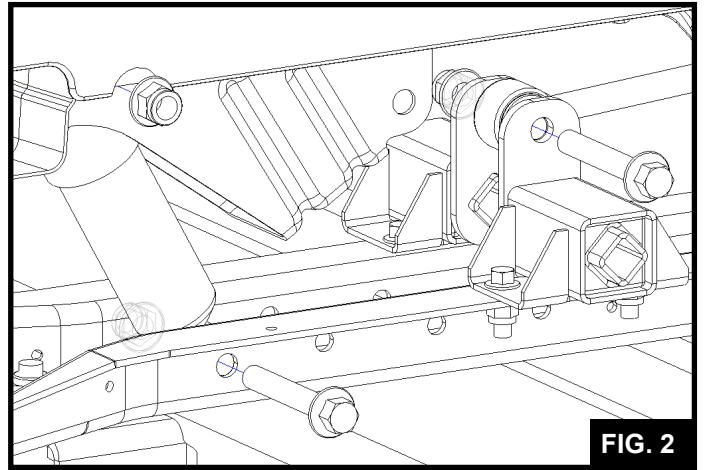

FIG. 2

6.2

Remove the air spring retaining ring. This is located on the underside of the crossmember where the air spring stem passes through. Use a screwdriver or similar tool to slowly pry the ring off. This part is not reused and may be discarded.

6.3

Repeat steps 6.1 & 6.2 on the drivers side of the truck.

6.4

Remove the bolt and nut from the lower lateral control rod connection. Retain these parts as they will be reused (**FIG.2**).

6.5

Remove the (4) bolts, (4) washers and (4) nuts that secure the lower lateral control rod mount assembly to the crossmember. Retain these parts and fasteners as they will be reused (**FIG.3**).

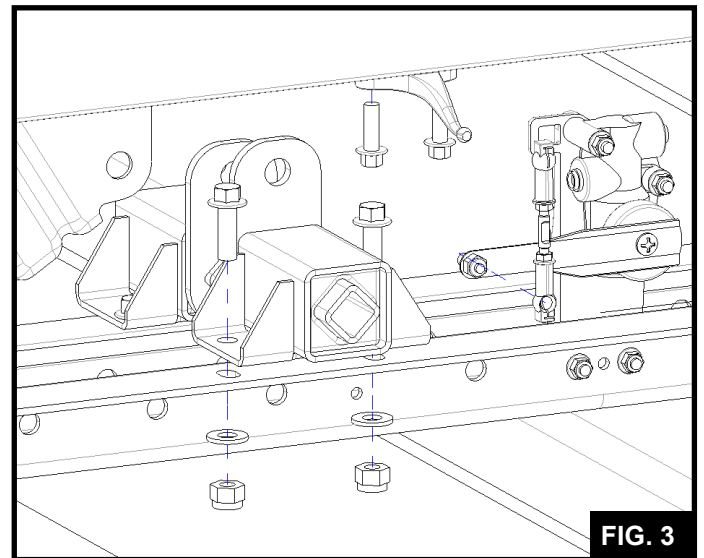

FIG. 3

6.6

Remove the (4) bolts and (4) nuts securing the crossmember to the frame of the truck. These parts are not reused and may be discarded (**FIG.4**).

6.7

Repeat step 6.6 on the drivers side of the truck.

NOTE: It may be necessary to remove the (4) nuts securing the crossmember to the frame mounts to remove the crossmember assembly. (Two nuts on each side) (**FIG.4**)

6.8

Remove the crossmember with the frame brackets from the truck. These parts will not be reused and may be discarded.

6.9

Remove the (2) bolts holding the pivot ball bracket to the cab. Retain these parts as they will be reused (**FIG.3**).

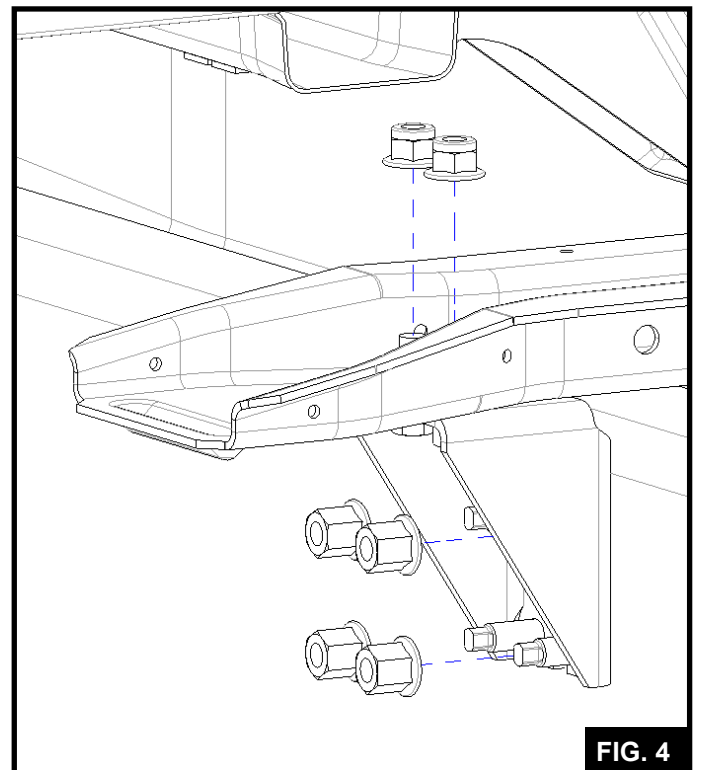

FIG. 4

7. INSTALL NEW CAB SUSPENSION COMPONENTS

7.1

Loosely attach the old lateral control rod assembly to the new crossmember using the fasteners removed in step 6.5. **DO NOT TIGHTEN** (FIG.5).

7.2

Mount the height control sensor to the tab on the crossmember using the (2) M5 X 10mm button head screws provided (FIG.5).

TORQUE M5 fasteners to 4-5 FT-LBS

7.3

Secure the control box to the crossmember using the (2) 1/4 X 5/8 flange head bolts provided (FIG.5).

TORQUE 1/4" fasteners to 4-5 FT-LBS

7.4

Mount the new drivers side frame bracket to the frame using the (4) 1/2 X 1 1/2 bolts, (4) nuts and (4) washers provided. (FIG.6).

TORQUE 1/2" fasteners to 60-70 FT-LBS

7.5

Repeat step 7.4 on the passenger side.

7.6

Connect the new crossmember assembly to the frame brackets using the (8) 1/2 X 1 1/2 bolts, (8) nuts and (8) washers provided (FIG.6). (4 per side)

TORQUE 1/2" fasteners to 60-70 FT-LBS

7.7

Using the (2) black straps provided, slip one around the length of each new ROI shock (FIG.6).

WARNING The straps are required to meet or exceed the tensile requirements of the stock suspension. The straps do not contribute or interfere with the functionality of the ROI Cabmate.

7.8

Starting on the passenger side of the truck, position the ROI shock between the mount locations and secure using the fasteners provided.

Top connection: (1) 1/2 X 4 bolt, (1) nut and (1) washer

Bottom connection: (1) 1/2 X 4 1/2 bolt, (1) nut (1) washer (FIG.6).

TORQUE 1/2" fasteners to 60-70 FT-LBS

NOTICE The ROI shock is gas-charged and may require the cab to be raised slightly to allow the free length of the shock to align with the mounting holes

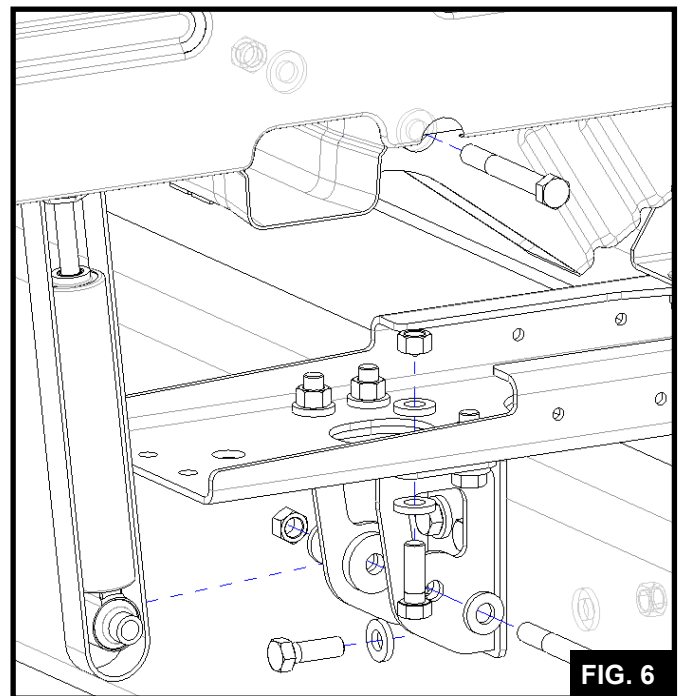
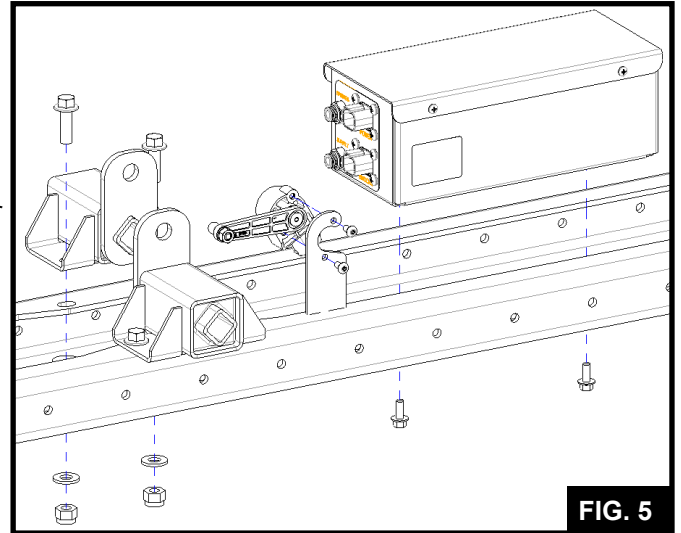

7.9

Reattach the lower lateral control rod joint using the fasteners removed in step 6.4.

NOTE: Refer to manufacturer's torque specifications.

7.10

Tighten the (4) bolts on the lower lateral control rod mount bracket to secure it to the crossmember.

See **FIG.5** for reference.

NOTE: Refer to manufacturer's torque specifications.

7.11

Position each air spring such that the base stem can pass through the mating hole in the crossmember. Secure using the new retaining rings provided.

7.12

Connect the pivot ball and accelerometer mount bracket to the cab using the same location and fasteners as removed in step 6.9 (**FIG.7**).

NOTE: Refer to manufacturer's torque specifications.

8. INSTALL NEW CAB SUSPENSION ELECTRICAL AND AIRLINE COMPONENTS

8.1

Connect the height control linkage between the pivot ball and the height control sensor (**FIG.7**).



WARNING

Connecting airlines to the vehicle supply and connecting to vehicle power may cause the cab air springs to inflate, resulting in cab movement. To prevent injury, ensure cab is blocked up and no operators are in the path of cab motion.

NOTE: The parts required for steps 8.2-8.8 are commodity parts and are **NOT INCLUDED** in this kit. Parts required are:

- Airline
- Airline push-to-connect fittings
- Automotive fuse
- Wire terminals and connectors

If these parts are not readily available to you please order the integration kit, Link part number 26303004.

8.2

Connect the air springs airlines together using a tee union fitting.

8.3

Connect the primary supply airline from the truck to the 'SUPPLY' port of the control box. Use a union fitting and additional airline to extend the supply line if necessary (**FIG.8**).

8.4

Connect a length of airline from the 'SPRINGS' port on the control box to the supply end of the air spring tee fitting (**FIG.8**).

8.5

Connect the accelerometer extension harness to the plug on the underside of the control box. Route the harness and connect it to the accelerometer.

8.6

Connect the shock extension harness into the 'SHOCKS' plug on the control box. Route one end of the harness to each shock absorber and connect. Ensure there is appropriate slack in the harness to account for the vertical suspension travel. Loop excess harness length and secure (**FIG.8**).

8.7

Run the main power harness from 'POWER' connector on the control box to ignition power. For recommended tie-in locations, see the OEM body builder manual, or instructions for Link kit 26303004. Run the black wire to ground. Loop excess harness length and secure (**FIG.8**).

8.8

Verify the key is in the off position and add a 10 amp fuse to the appropriate location in the vehicle fuse panel. **DO NOT TURN THE KEY ON AT THIS STEP.**

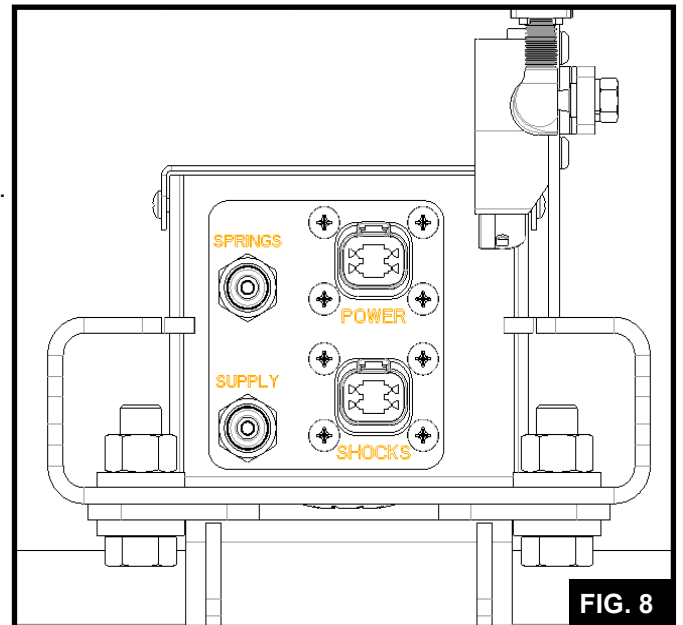
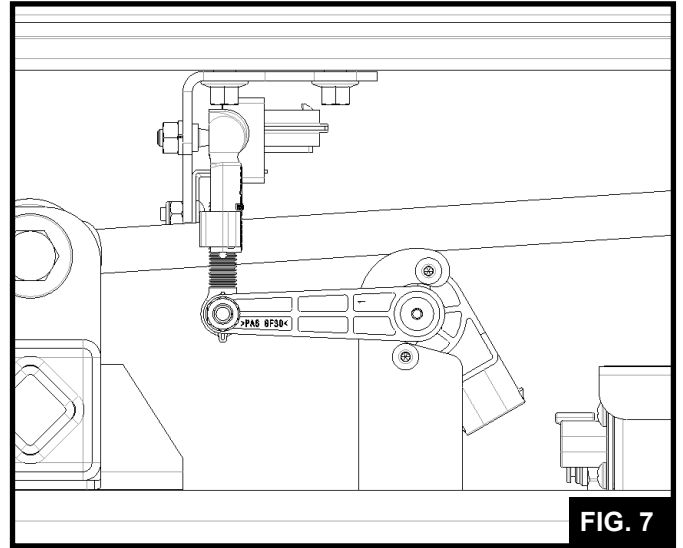

9. VERIFICATION OF INSTALLATION

9.1

Verify the position sensor arm is above horizontal, indicating that the suspension is below design height. At design height the sensor arm should be horizontal and perpendicular to the linkage. You may need to lower the jack(s) supporting the cab to achieve this (**FIG.7** and **FIG.9**).

9.2

Turn on the vehicle and allow the air tanks to fill. The cab air springs should now fill to design height.

9.3

Measure the air spring height as shown in (**FIG.1**) and verify it measures the same as recorded in step 5.1. If the design height is not correct, shut the vehicle off, adjust the linkage length accordingly, then restart the vehicle and repeat this step.

9.4

Remove the control box cover to verify the LED on the controller is flashing steadily, which indicates no faults. If the LED is not flashing steadily, see the Owner's Manual for troubleshooting information.

9.5

Check airline connections for air leaks and ensure all wire harnesses and airline is routed and secured appropriately.

9.6

Your ROI Cabmate installation is now complete. We hope you enjoy the ride. Please visit www.ROICabmate.com for more information or contact us at info@linkmfg.com if there is anything we can help you with.

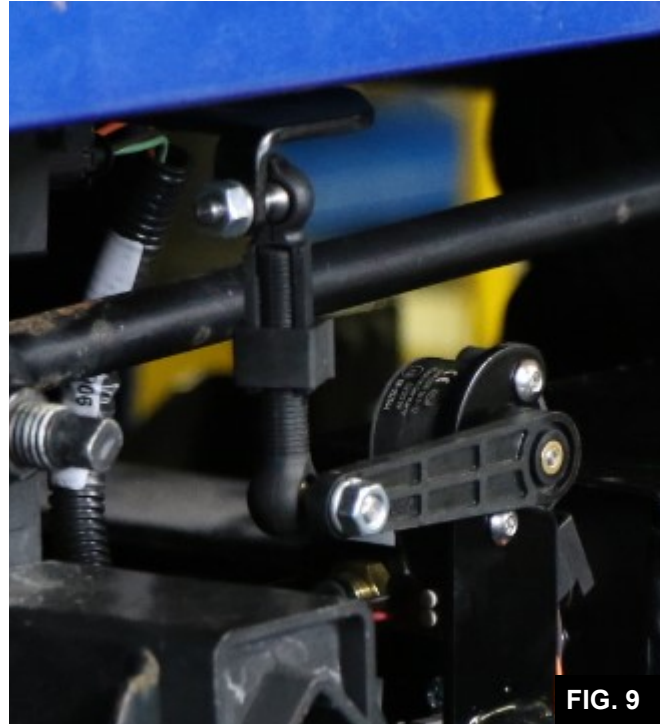

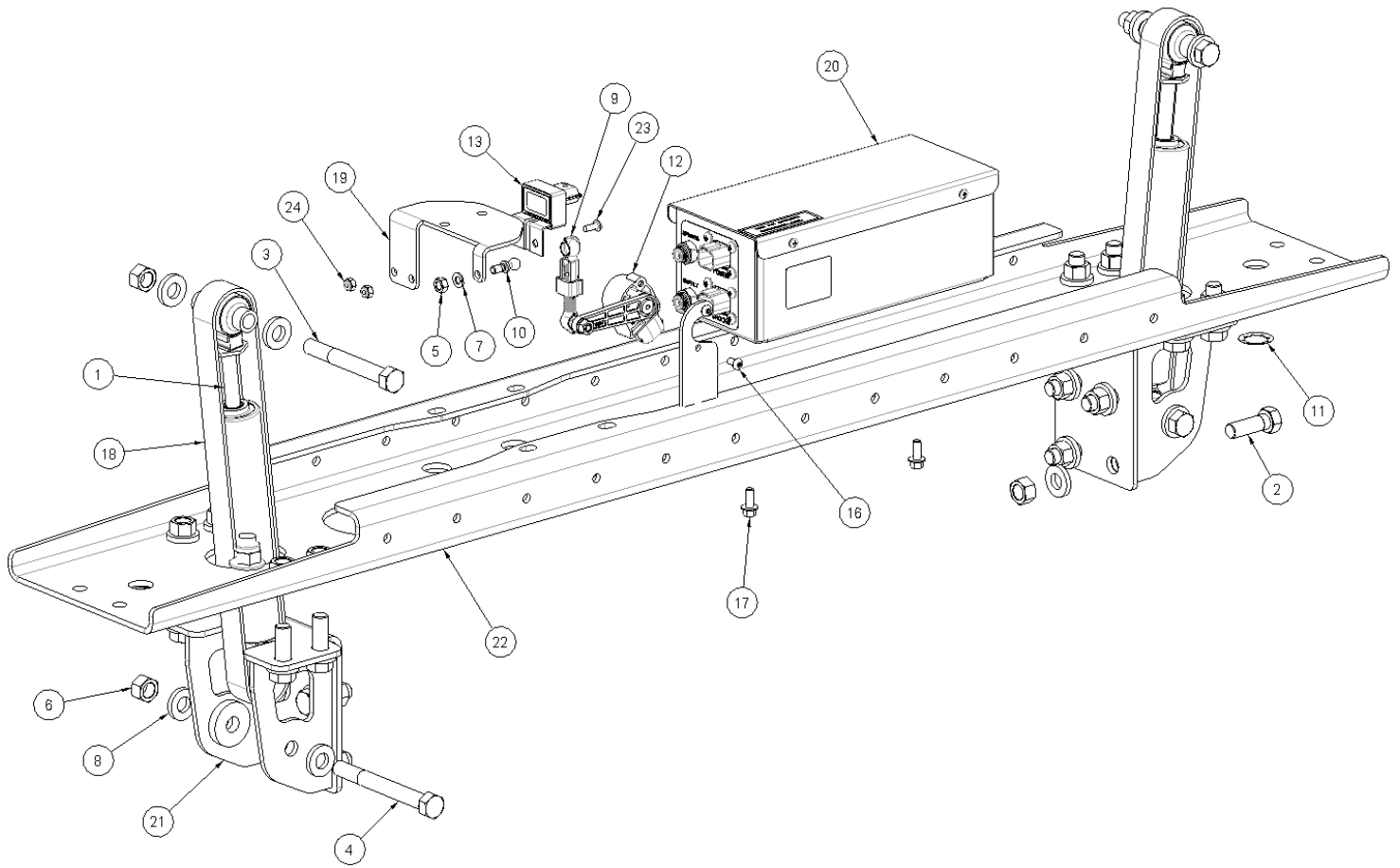

*NOT PICTURED

VOLVO VN SERIES ROI - ROI CABMATE PARTS LIST

ITEM	DESCRIPTION	QTY	ITEM	DESCRIPTION	QTY
1	SHOCK ABSORBER	2	13	ACCELEROMETER ASSEMBLY	1
2	1/2 X 1 1/2 UNC HEX CAP SCR (GR 5)	16	*14	HARNESS-WIRE, SHOCK	1
3	1/2 X 4 UNC HEX CAP SCR (GR 5)	2	*15	HARNESS-WIRE, POWER	1
4	1/2 X 4 1/2 UNC HEX CAP SCR (GR 5)	2	16	M5X10 SOCKET BUTTON HD SCREW	2
5	1/4 UNC HEX NUT (GR B)	2	17	1/4 X 5/8 FLANGE HEAD BOLT	2
6	1/2 UNC HEX TOP LOCK NUT (GR C)	20	18	STRAP-RETENTION	2
7	1/4 LOCK WASHER	2	19	BRACKET-MOUNT, ACCELEROMETER	1
8	1/2 HARDENED WASHER, ZINC PLATED	40	20	CONTROL BOX ASSEMBLY	1
9	LINKAGE-VALVE	1	21	BRACKET-MOUNT, FRAME	2
10	BALL-PIVOT, THREADED	2	22	CHANNEL-CROSSMEMBER, LCR-AIRSPRING	1
11	3/4 RETAINER RING	2	23	10-24 x 1/2 PH SCREW	2
12	SENSOR-POSITION	1	24	10-24 NYLOCK NUT, SS	2



LINK MANUFACTURING, LTD.
 223 15TH ST. NE, SIOUX CENTER, IA 51250
 1-800-222-6283 www.linkmfg.com