

# INSTALLATION INSTRUCTIONS

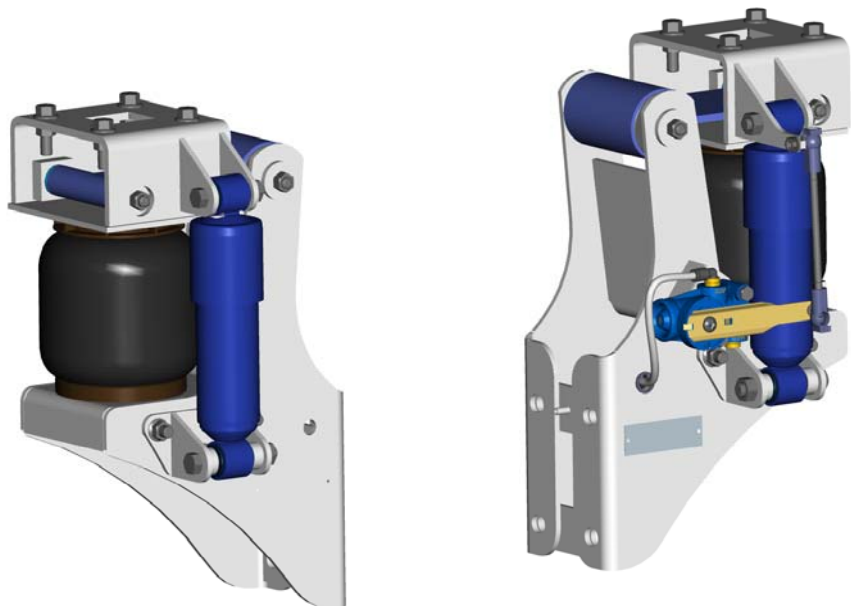

## FRT46-2P-B (2262-C000)



The **CABMATE MODEL FRT46-2P-B** fits most 1993 and newer Freightliner FLB Cabover tractors with 90", 100", and 110" cabs. It replaces the stock rear cab mounts, Freightliner Part No. 18-28734-000.

Link mfg. Ltd.  
223 15th St. N.E.  
Sioux Center, IA USA  
51250-2120

(712) 722-4874  
Fax (712) 722-4876

**QUESTIONS?  
CALL CUSTOMER  
SERVICE  
1-800-222-6283**

UNIT WEIGHT : 55.3 LB.

NET WEIGHT ADDED: 20.7 LB.

# CABMATE MODEL FRT46-2P-B

Review the Parts List on page 3 to become familiar with the different components of the CABMATE.

**IMPORTANT:** Due to many chassis variables caused by installation of special equipment or options, the fit of the FRT46-2P-B CABMATE may be affected and should be evaluated before beginning installation.

**IMPORTANT:** Installation of the CABMATE system will allow the cab to move freely. Before starting installation, check clearances between the cab and any objects the cab may contact when it moves (1 1/2 inches of clearance should be sufficient). The clearance of components that are affected by cab movement, such as exhaust and radiator systems, must also be evaluated.

A. Raise the cab and remove the hydraulic latch from the top of the original mount. Remove the lower rear cab mounts and save all stock mount bolts (Fig. 1).

B. Securely fasten both halves of the CABMATE to the frame using the stock mount bolts (Fig. 2).

C. Loosely fasten the hydraulic latch to the CABMATE using the 3/8 x 1 1/4 UNC Grade 8 fasteners supplied by LINK Mfg. (Item No. 13 and 19 from the Parts List).

D. See page 2 for plumbing instructions and height adjustments.

E. With the air system at working pressure 90-110 psi, lower the cab slowly. Make sure the cab aligns properly with the latches. **NOTE:** There are slots in the top of the CABMATE to allow fore-aft adjustment, and slots in the latch to allow lateral adjustment. **SECURELY TIGHTEN ALL FASTENERS.**

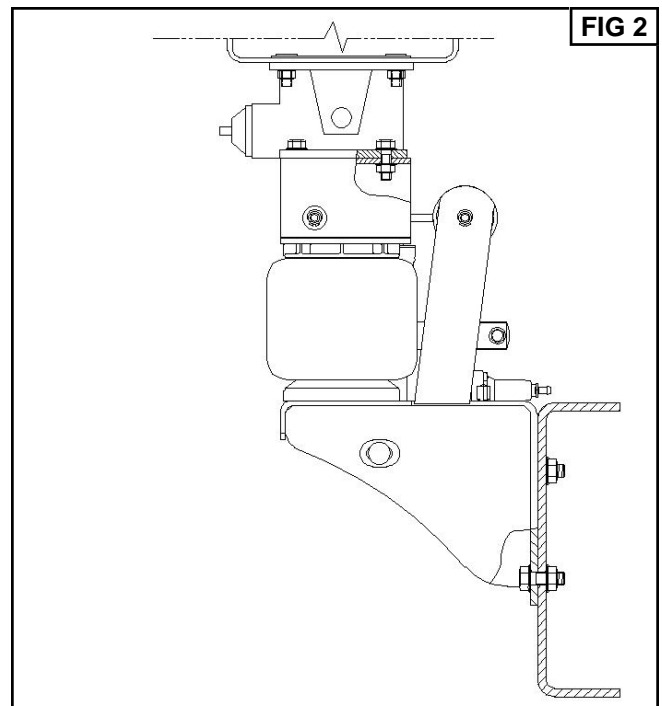
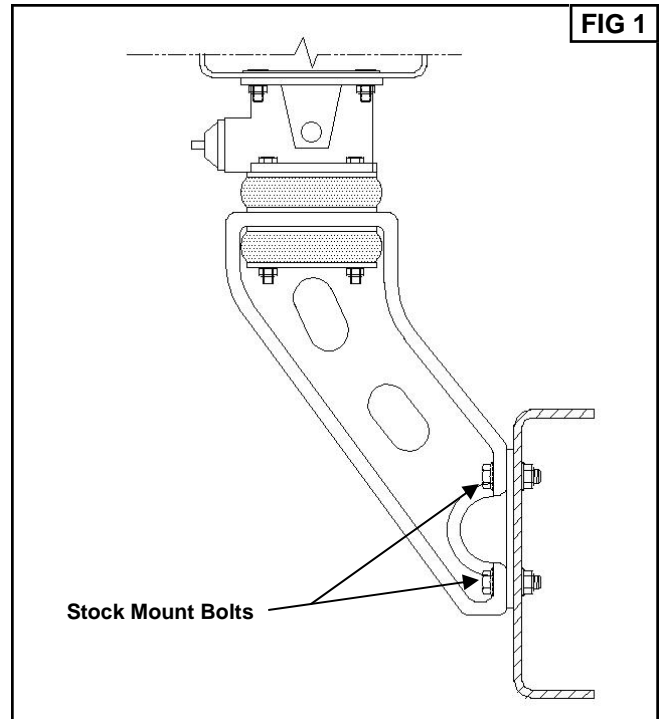

## PLUMBING INSTRUCTIONS

**WARNING: FOR SAFETY PURPOSES THE CABMATE MUST BE SUPPLIED FROM A PRESSURE PROTECTED CIRCUIT. IN THE EVENT OF AN AIR LEAK IN THE CAB SUSPENSION, FAILURE TO PROVIDE A PRESSURE PROTECTED CIRCUIT MAY CAUSE LOSS OF AIR PRESSURE TO VITAL SYSTEMS ON THE VEHICLE.**

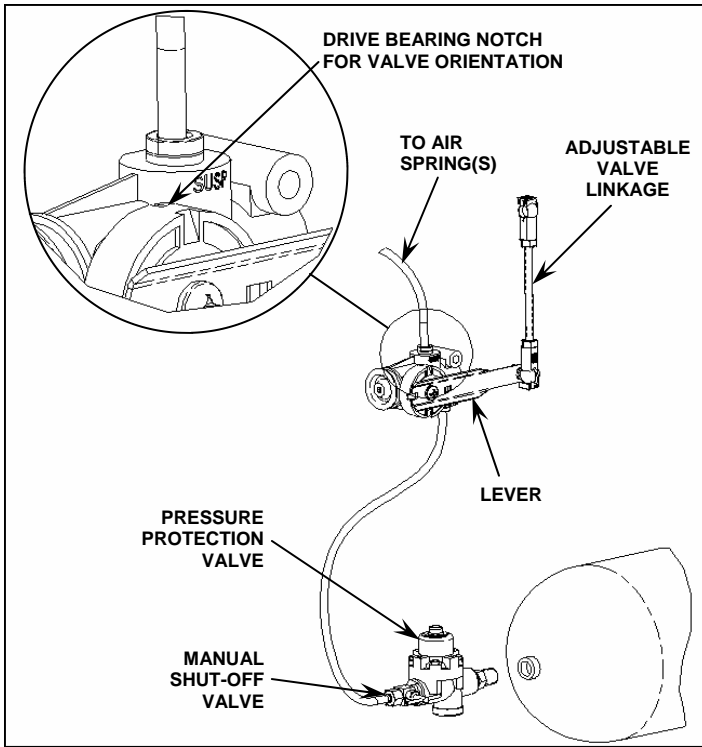

**WARNING: LOSS OR APPLICATION OF AIR PRESSURE TO CABMATE WILL CAUSE SUDDEN MOVEMENT OF THE CAB. PRIOR TO INSTALLING OR PERFORMING MAINTENANCE, BLOCK UP THE CABMATE TO PREVENT THE POSSIBILITY OF INJURY.**

**WARNING: CONNECT THE CABMATE DIRECTLY TO THE MAIN AIR TANK. YOU WILL NEED AN AIR PRESSURE PROTECTION VALVE IN THE LINE. (INCLUDED IN THE PRESSUREPROTECTION KIT. LINK MFG. PART NO. 1350-0000). DO NOT USE AN AIR PRESSURE REGULATOR!**

**A.** With the tank at 0 p.s.i., remove the existing plug or fitting from the desired port.

**B.** Apply joint compound to the fittings and install the pressure protection kit. **DO NOT USE TEFLON TAPE.** Be sure that the arrows on the valve are pointing in the direction of air flow and the vent hole is pointed down. **NOTE:** Additional fittings/reducers may be required to attach the hex nipple to the main air tank.

**C.** Run the 1/4" airline from the shut-off valve to the CABMATE. Be sure that the airline has enough clearance so that there are no pinch points that may restrict or cut the airline. Secure the airline using the cable ties supplied by Link Mfg.

**D.** Tighten all plumbing fittings. Then, with the system at operating pressure (90 to 110 p.s.i.), open the Manual Shut-off Valve to supply air to the CABMATE. Check the system for air leaks.

**E.** Check for proper operation of the height control valve. Disconnect the valve linkage from the lever. Push the lever down 45°, air should flow into the air spring(s). Return the lever to the neutral position. Push the lever up

45°, air should exhaust from the air spring(s). Return the lever to the neutral position; no air should flow. Reconnect the valve linkage to the lever.

### HEIGHT ADJUSTMENTS

Measure the design height of the air spring(s). The height should be 5.75 inches  $\pm$  1/16. To change the height, disconnect one end of the valve linkage and adjust accordingly. Tighten the lock nuts on the valve linkage.

### MAINTENANCE

CABMATES need no lubrication and little maintenance. The following components should be checked at the time the truck is being serviced. However, immediate corrective action should be taken if a serious malfunction occurs.

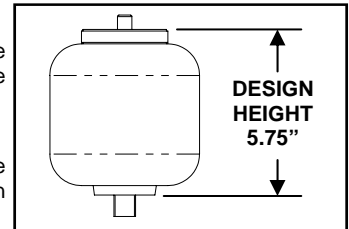

COMPONENT	POSSIBLE PROBLEM	CORRECTIVE ACTION	TORQUE
<b>Airlines</b>	Air leaks	Replace airline	<b>Compression Nut</b> Hand Tight + 1 Turn
<b>Fittings</b>	Air leaks	Remove fitting and apply fresh joint compound. Reinstall fitting, but <b>Do Not Overtighten. Do not use teflon tape.</b>	<b>Threaded into:</b> <b>Metal</b> <b>Plastic</b> 15      Hand Tight Ft. Lbs.      + 1 Turn
<b>Air Springs</b>	<b>A.</b> Improper height <b>B.</b> Air leakage	<b>A.</b> Adjust valve linkage to maintain proper air spring height. <b>B.</b> Replace air spring.	<b>Size</b> <b>Metal</b> <b>Plastic</b> <b>3/8</b> 25 Ft. Lbs      04 Ft. Lbs <b>1/2</b> 28 Ft. Lbs      10 Ft. Lbs <b>3/4</b> 30 Ft. Lbs      10 Ft. Lbs
<b>Height Control Valve</b>	Air spring(s) will not inflate when weight is added to the cab; <b>OR</b> Air spring(s) will not deflate when weight is removed from the cab.	<b>A.</b> Inspect valve to insure drive bearing notch is located on "SUSP" port side of valve. If not, loosen lever screw (but do not remove completely) and pull lever loose from drive bearing, rotate drive bearing until the bearing notch is in the correct position and resecure lever by tightening lever screw. <b>B.</b> Replace Valve	<b>1/4 Mount Fasteners</b> 10 Ft. Lbs.  <b>Bearing Screw</b> 40-50 InLbs.
<b>Shock Absorber</b>	Insufficient dampening effect	Replace shocks	45 Ft. Lbs.
<b>Lateral Control Rod</b>	<b>A.</b> Loose nuts on lateral control rod bolts <b>B.</b> Worn bushings.	<b>A.</b> Tighten securely to clamp the inner sleeve. <b>B.</b> Replace lateral control rod.	40 Ft. Lbs.

**IMPORTANT:** Periodically check the tightness of all fasteners.

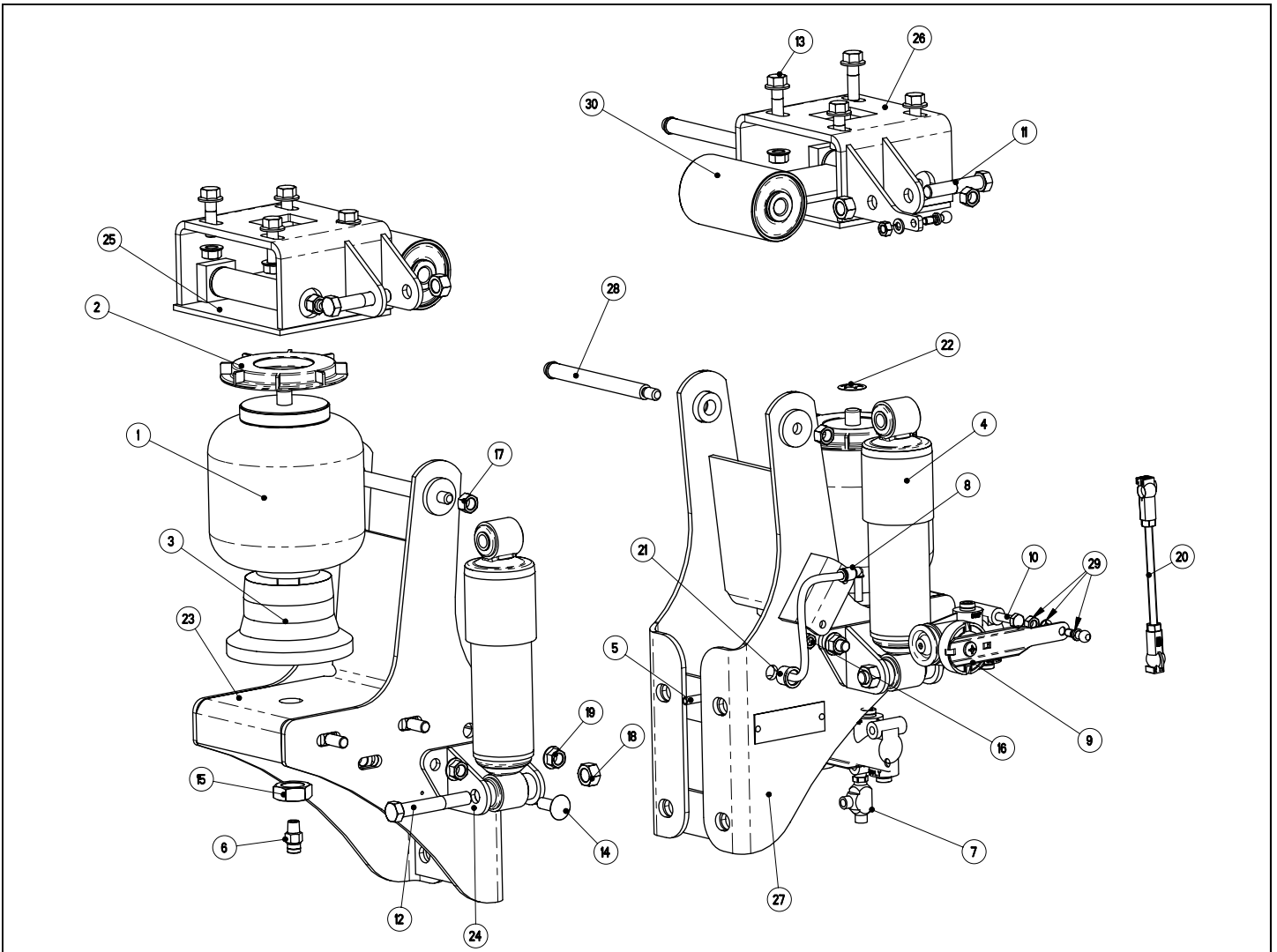

### CABMATE® MODEL FRT46-2P-B PARTS LIST

ITEM	PART NO.	DESCRIPTION	QTY	ITEM	PART NO.	DESCRIPTION	QTY
1	1102-0047	SPRING-AIR	2	16	1476-0800	1/4 UNC HEX CTR LOCK NUT (GR B)	2
2	1109-8001	ACCESSORY PISTON-UPPER	2	17	1476-1201	3/8 UNC HEX TOP LOCK NUT (GR C)	4
3	1109-8002	ACCESSORY PISTON-LOWER	2	18	1477-1400	7/16 UNF HEX CTR LOCK NUT (GR B)	4
4	1201-0054	SHOCK ABSORBER	2	19	1480-1201	3/8 UNC TOP LOCK FL NUT (GR F)	14
5	1302-0090	AIRLINE-NYLON, .250 O.D., BULK	1.0 ft	20	1500-0260	LINKAGE-VALVE, HEIGHT CONTROL (5.75)	1
6	1302-5045	CONNECTOR, 1/4 TB 1/8 M-NPT, PUSH-IN DOT	1	21	1500-0303	SNAP BUSHING (.250 MAT'L)	1
7	1302-5130	RUN TEE, 1/4 TB 1/8 M-NPT, PUSH-IN DOT	1	22	1500-0320	1/2 RETAINER RING	2
8	1302-5499	ELBOW, 1/4 TB 1/4 PTC, PUSH-IN DOT	1	23	2261-4000	BRACKET-MOUNT, FRAME, RH	1
-	1350-0000	KIT-PROTECTION, PRESSURE	1	24	2261-5000	MOUNT-SHOCK ABSORBER	2
9	1350-0101	ASSEMBLY-HEIGHT CONTROL VALVE	1	25	22612000	BRACKET-MOUNT, LATCH, RH	1
10	1401-0814	1/4 X 1 3/4 UNC HEX CAP SCR (GR 5)	2	26	2262-1000	BRACKET-MOUNT, LATCH, LH	1
11	1403-1418	7/16 X 2 1/4 UNF HEX CAP SCR (GR 5)	2	27	2262-3000	BRACKET-MOUNT, FRAME, LH	1
12	1403-1424	7/16 X 3 UNF HEX CAP SCR (GR 5)	2	28	2990-0502	BOLT-HINGE ARM (4.75)	4
13	1411-1210	3/8 X 1 1/4 UNC FLANGE BOLT (GRADE 8) O&P	8	29	2991-0026	KIT-PIVOT BALL	1
14	1435-1208	3/8 X 1 UNC RND HD SQ NK BOLT (GRADE 5)	6	30	2992-2010	HINGE ARM, TYPE A (5.500)	2
15	1475-2400	3/4 UNF HEX JAM NUT	2	-	3262-1000	KIT-DOCUMENT, FRT46-2P-B (AFTM)	1