

LINK® UltraRide® Chassis Air Suspension

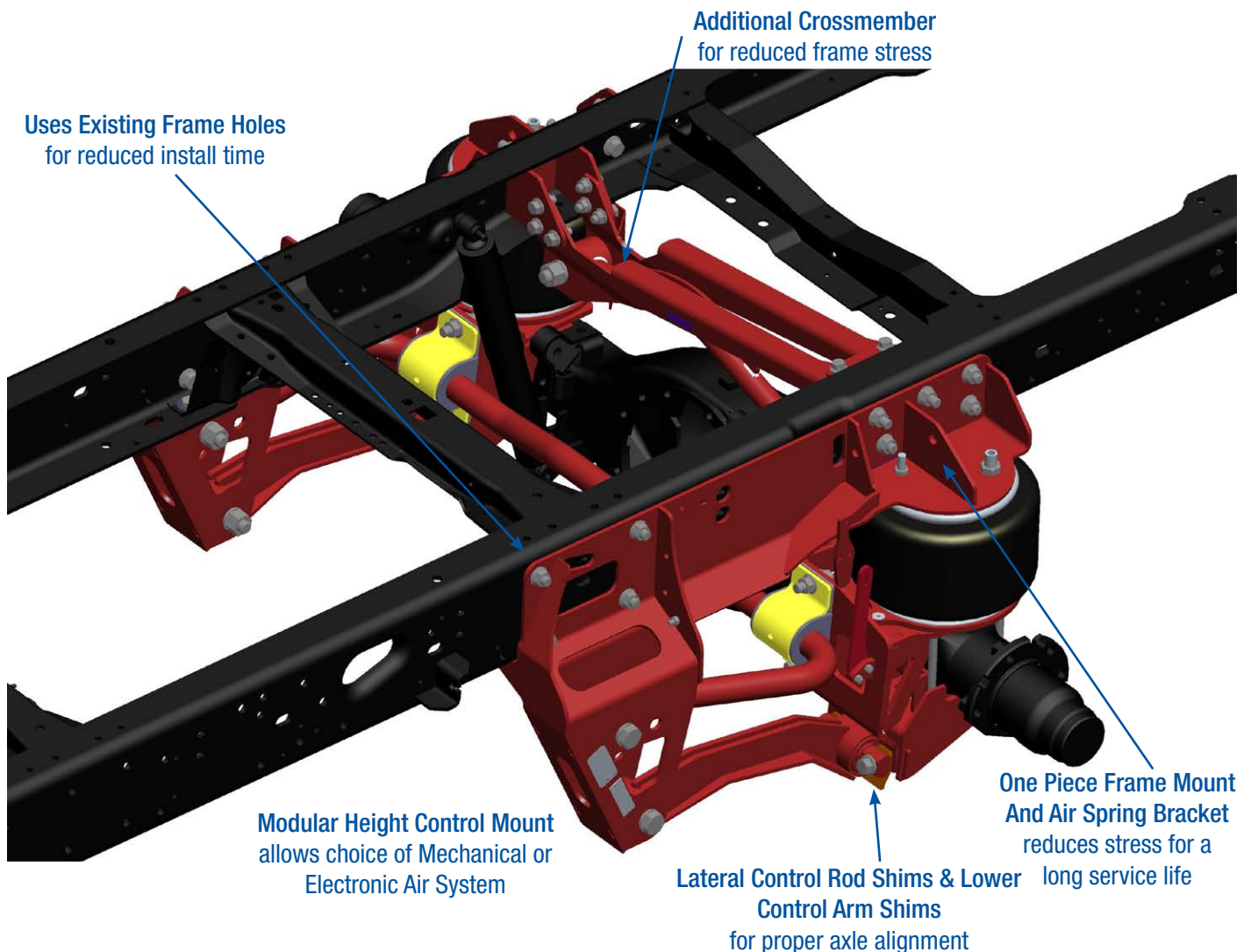

FORD F450/550 CHASSIS CAB

Compatible with either Severe Duty Electronic Air Kit or Link®'s Commercial Duty Mechanical Air Kit.



The 8M000097 UltraRide® Suspension Includes:

- Basic Unit
- Integrated 1^{3/4}" Stabilizer Bar
- Custom Tuned UltraRide Shocks

Ultra Support for UltraRide Dealers

- No Minimum Inventory Requirements
- Standard Warranty
- Up-to-Date Installation, Owner's Manual and Parts Drawings Available Online 24 Hours a Day
- Free Shipping on Orders of 10+ Units
- Competitive Pricing
- Factory Customer Service Support



Suspension Specifications:

Model: Ford F450/550 Chassis Cab

Year: 2005 - Newer

Ride Height (top frame to axle center @ axle): 17.6"

Air Spring Design Height: 8.0"

Axle Travel: 3.10" Jounce (B/C)
3.71" Jounce (M/M)
3.10" Rebound (M/M)

Link Part Number: 8M000097

Style: Parallelogram

Installation Notes:

- Exhaust hanger may need to be modified slightly in case the exhaust is closer than 1" away from the suspension exhaust shield.
- Minor relocation of brake cable.
- Drill frame holes for frame hanger mount plates.

Suspension Weight: 375 lbs

Suspension Capacity: 12,000 lbs, 13,600 lbs

Top View

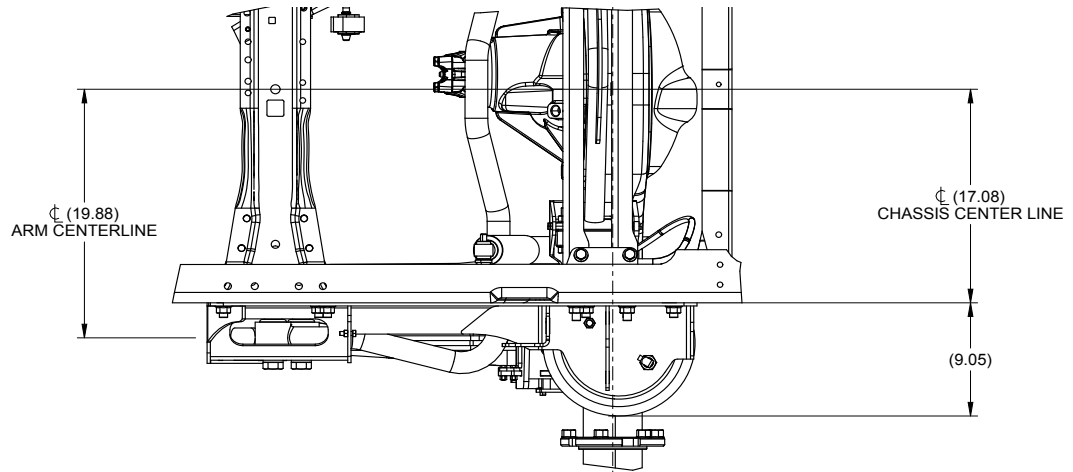

Side View

