

LINK® UltraRide® Chassis Air Suspension

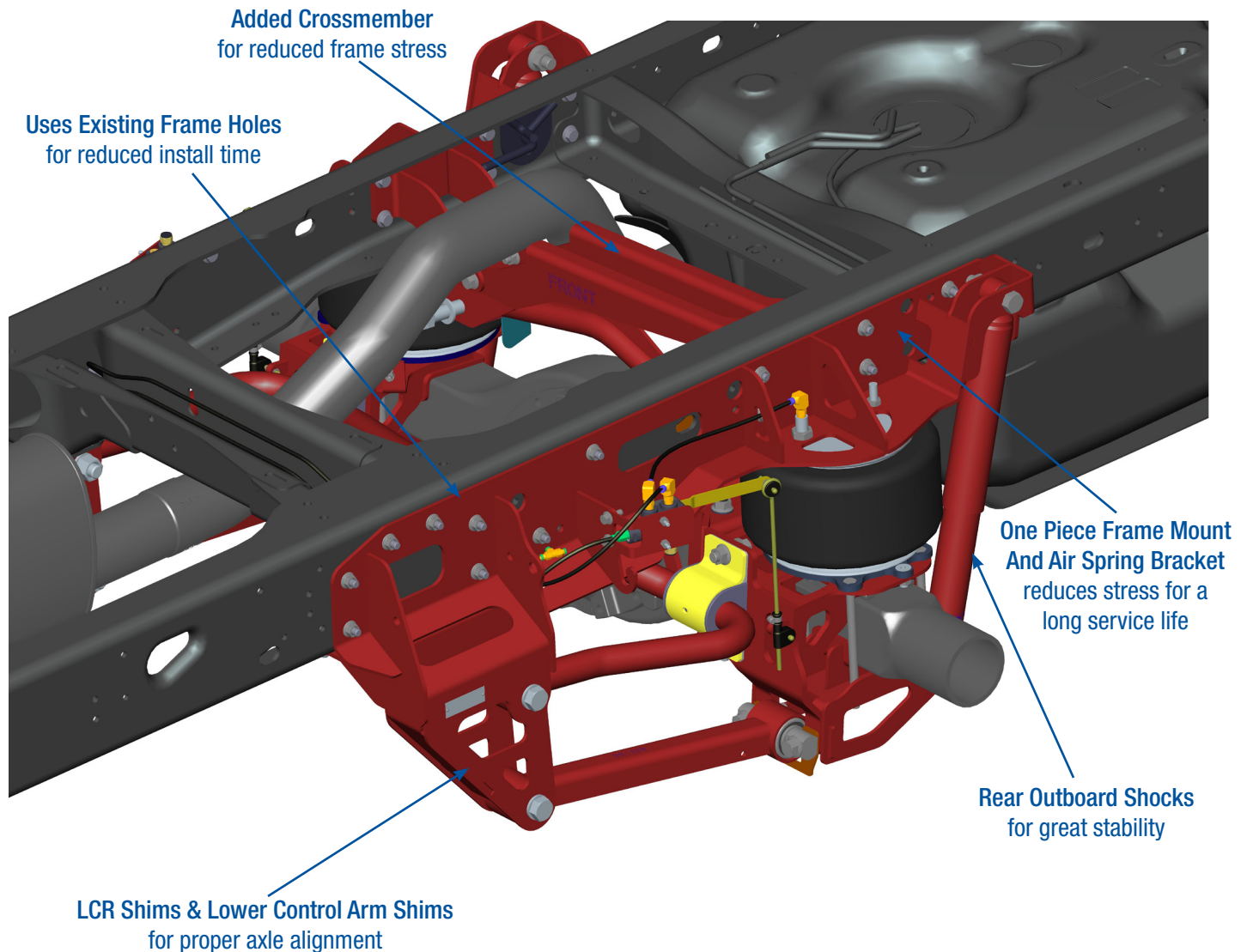

DODGE RAM 4500/5500 4X2 & 4X4



The 8M000100 UltraRide® Suspension Includes:

- Basic Unit
- Integrated 1^{3/4}" Stabilizer Bar
- Axle Kit
- Custom Tuned UltraRide Shocks

Ultra Support for UltraRide Dealers

- No Minimum Inventory Requirements
- Standard Warranty
- Up-to-Date Installation, Owner's Manual and Parts Drawings Available Online 24 Hours a Day
- Free Shipping on Orders of 10+ Units
- Competitive Pricing
- Factory Customer Service Support



Suspension Specifications:

Model: Dodge Ram 4500/5500

Year: 2008 - Newer

Ride Height (top frame to axle center @ axle): 17.80"

Air Spring Design Height: 7.50"

Axle Travel: 2.9" Jounce (B/C)
4.0" Jounce (M/M)
2.9" Rebound (M/M)

Link Part Number: 8M000100

Style: Parallelogram

Installation Notes:

- Need to remove jounce bumper from underside of frame
- Need to remove spring pad from top of axle
- Drilling required at Air Spring/Shock location

Suspension Weight: 450 lbs

Suspension Capacity: 12,000 lbs, 13,500 lbs

Top View

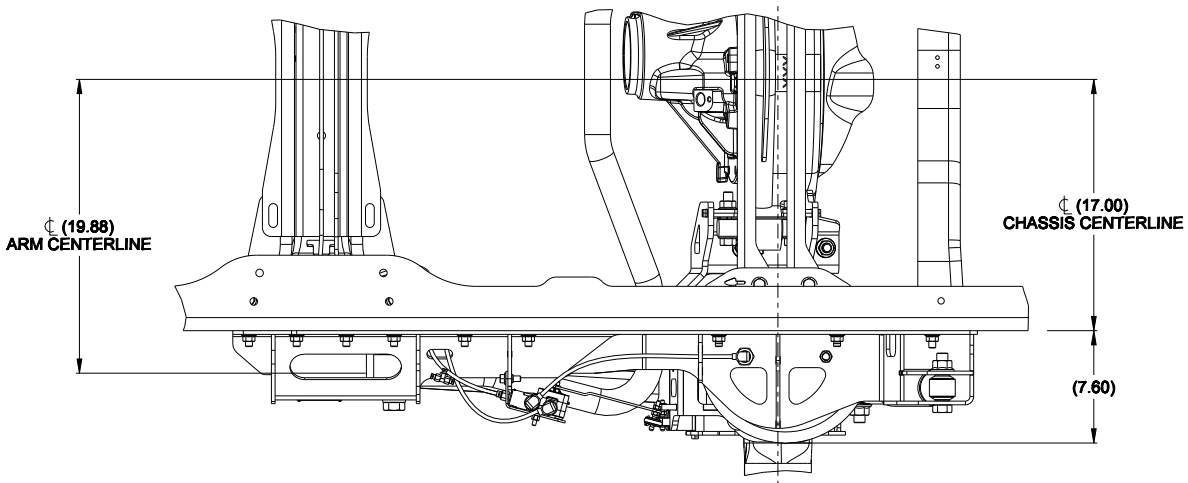

Side View

