

## INSTALLATION

The Link Air Dryer Kit reduces drain service intervals and improves system reliability by removing moisture and contamination from the compressed air supply.

1. Release all air pressure from the air tank.
2. Assemble the (2) Air Fittings to the “IN” and “OUT” ports and Pressure Switch to the Pilot Port on the Air Dryer.
3. Mount the Air Dryer in the upright position directly to the frame or use the included mounting bracket to mount the dryer to the frame.

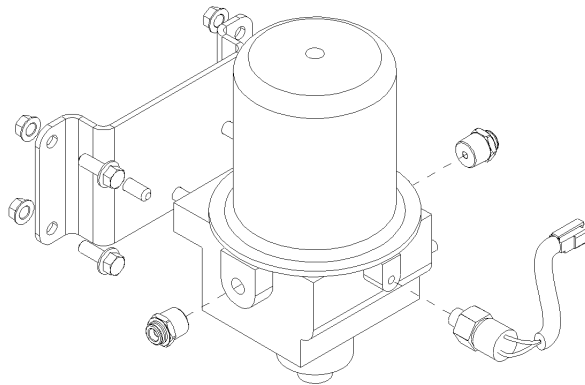

4. Remove the cover from the Air Kit and remove the components as shown below.
5. Reassemble the removed air fitting into the manifold as shown. (For units prior to 4/07, additional fittings are included in the kit.)
6. Cut the drill template as shown on page 4, align the cut edges with the corresponding sides of the Air Kit Housing and tape it to the air kit housing. Center punch the (3) holes, remove the template, and drill the (2)  $\text{Ø}.66$  holes and the  $\text{Ø}.78$  hole. Insert the rubber grommets into the drilled holes.

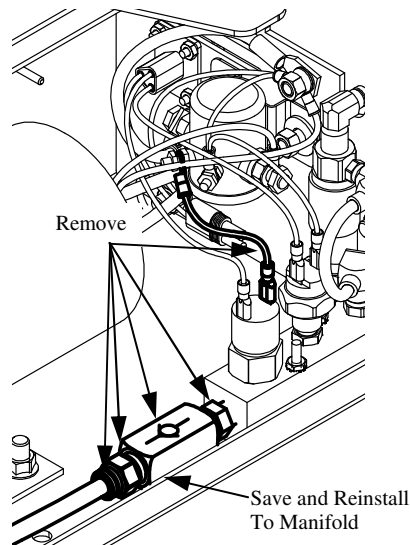

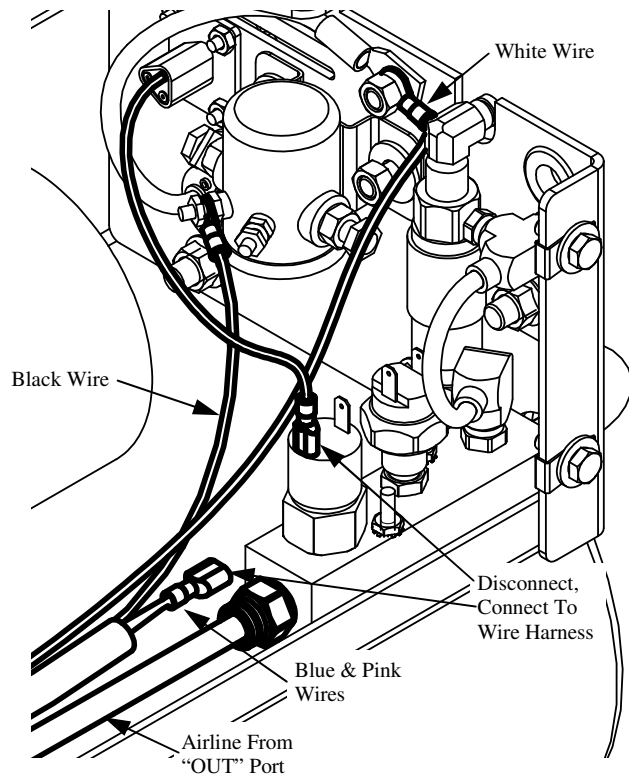

7. Cut supplied air line to required lengths. Connect from the compressor to the "IN" port of the Dryer. Connect the other airline from the "OUT" port to the reassembled fitting as shown.
8. Route supplied Wire Harness as shown. Connect the (2) deutsch plugs with the (2) plugs on the Air Dryer.
9. Disconnect the wire shown and connect with the blue and pink wire connector on the wire harness.
10. Connect the Black Wire to the relay terminal as shown.
11. Connect the White Wire to the ground post as shown.
12. Reinstall the Air Kit Housing Cover.
13. On the control panel 800M1074 mounted in the cab, replace the existing 2A fuse with the supplied 7A fuse.

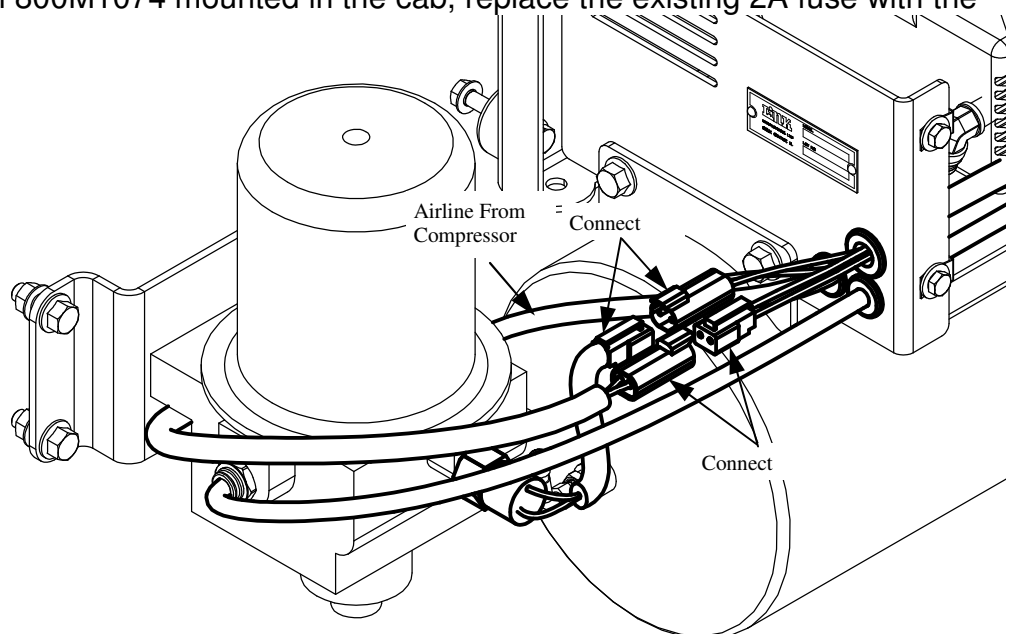

# ***UltraRide* – Air Dryer Update Kit**

ITEM	PART NO.	DESCRIPTION	QTY
1	13010573	DRYER-AIR, WITH GOVONOR	1
2	13010575	SWITCH-PRESSURE, 60/120	1
3	1302-5050	CONNECTOR-MALE, 3/8 TB, 3/8 NPT	1
4	1302-5100	ELBOW-3/8 TB, 1/4 M-NPT	2
5	13025056	CONNECTOR-MALE, 3/8 TB, 1/2 NPT	2
6	1303-4000	AIRLINE-NYLON, .375 O.D.	7 FT
7	14071005	HEX CAP SCR, M10 X 1.25 X 25, CLASS 8.8	3
8	141A-1208	3/8 X 1 UNC FLANGE BOLT (GRADE 8) O&P	4
9	1480-1204	3/8 UNC TOP LOCK FL NUT (GR G) O&P	4
10	1500-0308	GROMMET-RUBBER, 3/8	2
11	15000312	GROMMET-RUBBER, 1/2	1
12	15051873	7 AMP FUSE	1
13	15051874	HARNES-AIR DRYER, ULTRARIDE	1
14	80002145	BRACKET-MOUNT, DRYER	1

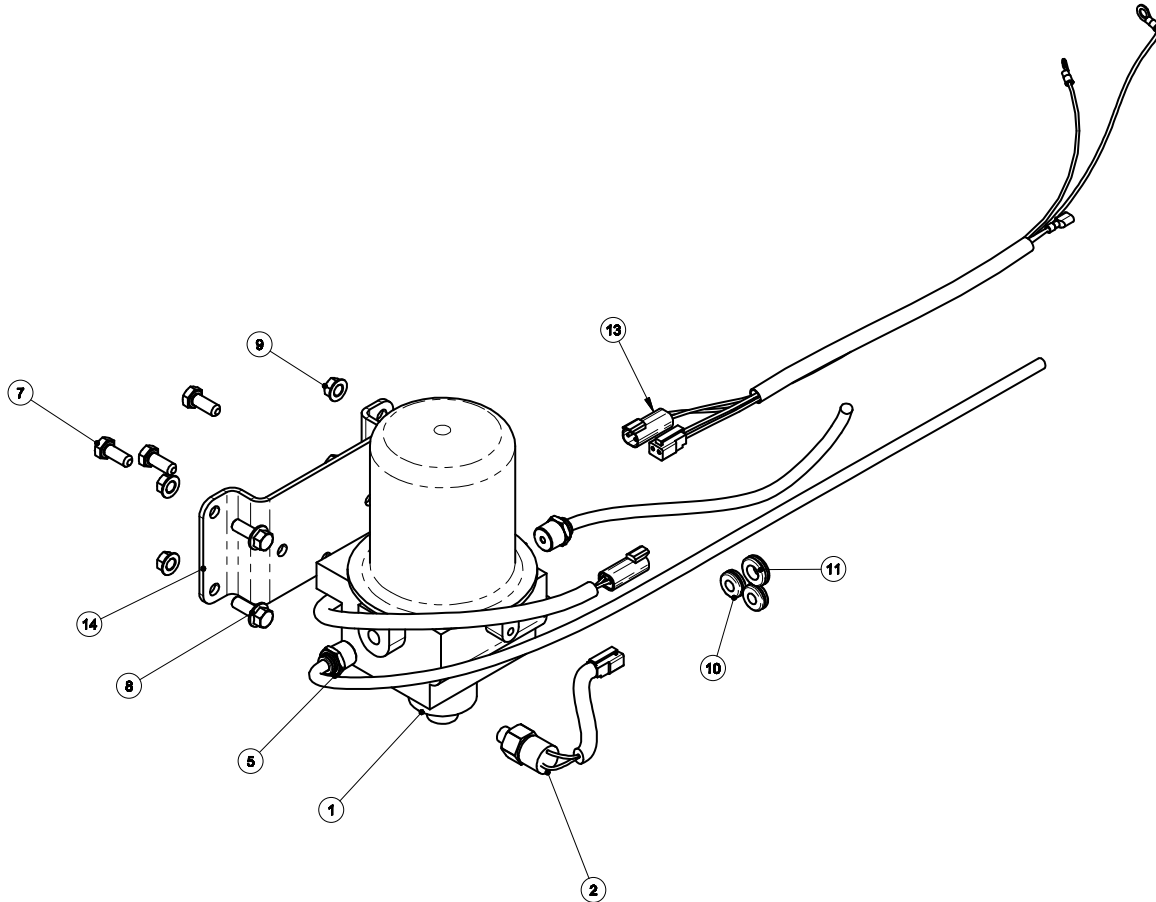

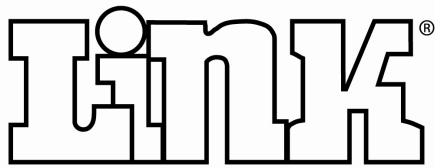
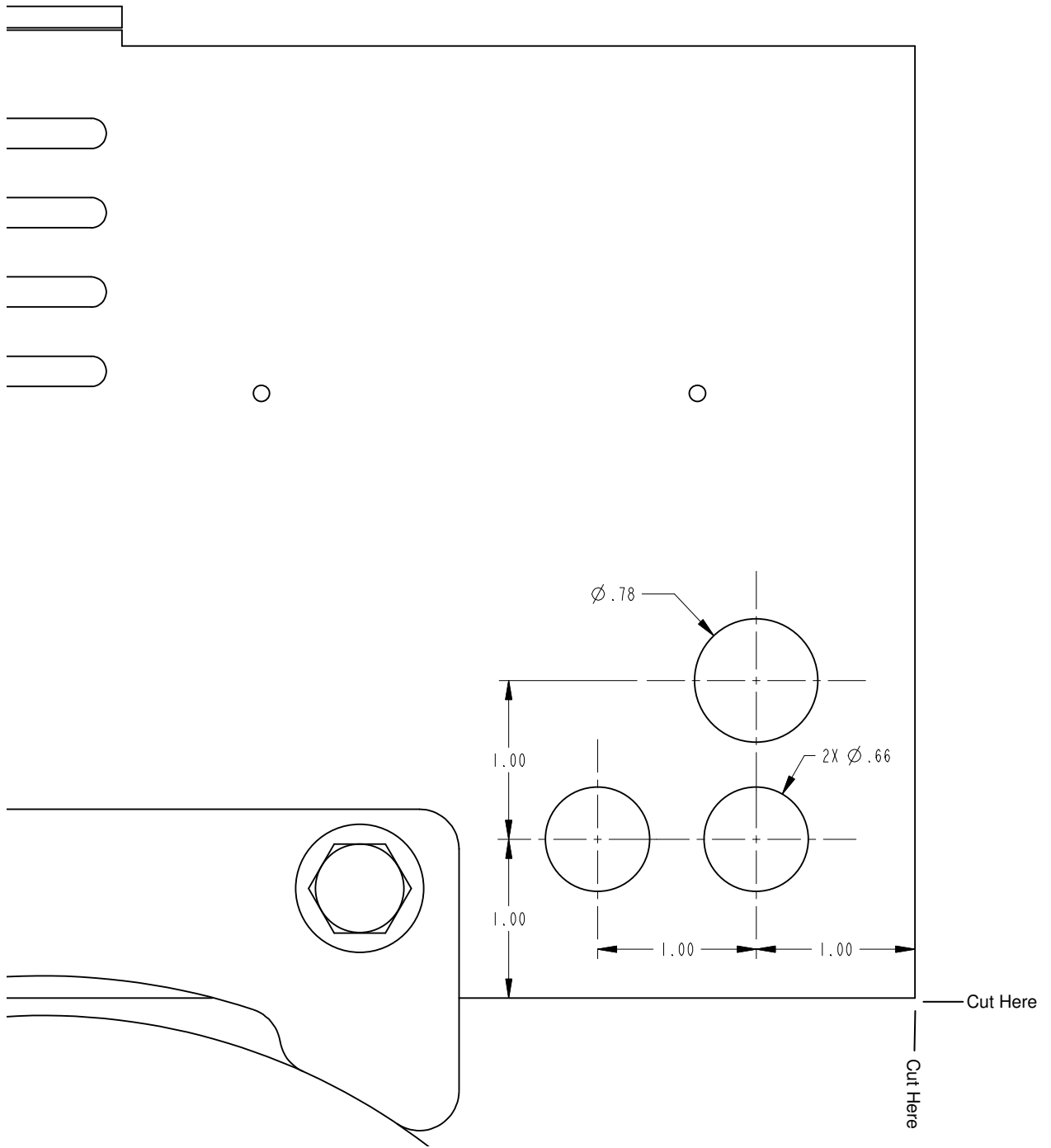

Link Mfg. Ltd.  
 223 15th St. NE  
 Sioux Center, IA USA  
 51250-2120  
 (712) 722-4874  
<http://www.linkmfg.com/>