

INSTALLATION INSTRUCTIONS

Link mfg. Ltd.
223 15th St. N.E.
Sioux Center, IA USA
51250-2120

(712) 722-4874
Fax (712) 722-4876

**QUESTIONS?
CALL CUSTOMER
SERVICE
1-800-222-6283**

LINK[®]

Liftable Suspensions

INSTALLATION INSTRUCTIONS PARTS LIST

STEERING LOCK KIT (800A0154)

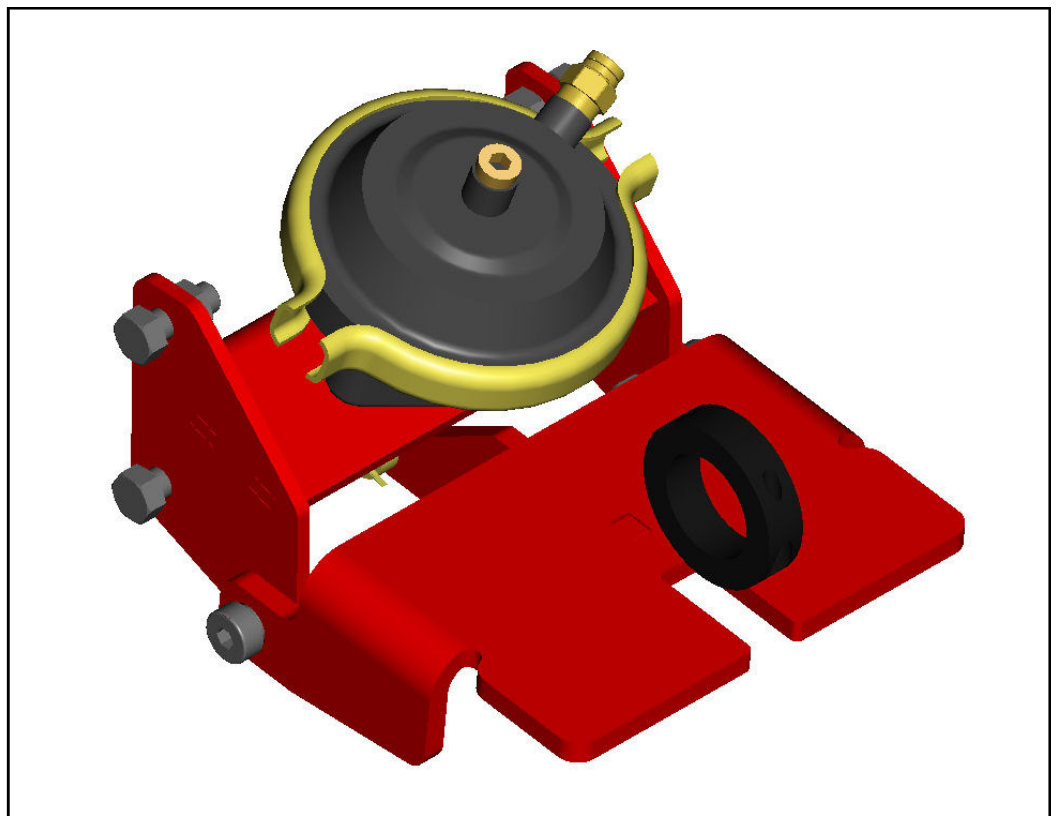

The **STEERING LOCK KIT** is used for Link Duralift II 20K Suspension.

1. INTRODUCTION



Thank you for choosing a Link Duralift II liftable suspension. We want to help you to get the best results from the suspension and to operate it safely. This manual contains information to introduce you to the Link Duralift II liftable suspension Steering Lock Kit and to assist you with its installation and maintenance. The manual is intended solely for use with this product.

All information in this manual is based on the latest information available at the time of printing. Link Manufacturing reserves the right to change its products or manuals at any time without notice. Contact Link at (800) 222-6283 for information on recent changes to products.

Defective or damaged components should be returned to Link with a pre-arranged Returned Goods Authorization (RGA) number through the Customer Service Department. The damaged or defective component may then be replaced if in compliance with warranty conditions.

IMPORTANT: IT IS IMPORTANT THAT THE ENTIRE INSTALLATION INSTRUCTIONS BE READ THOROUGHLY BEFORE PROCEEDING WITH INSTALLATION FOR THIS KIT.

2. SAFETY SYMBOLS, TORQUE SYMBOL, and NOTES

	This is the safety alert symbol. It is used to alert you to potential personal injury hazards. Obey all safety messages that follow this symbol to avoid possible injury or death.
	WARNING indicates a potentially hazardous situation which, if not avoided, could result in death or serious injury.
	CAUTION indicates a potentially hazardous situation which, if not avoided, could result in minor or moderate injury.
CAUTION	CAUTION used without the safety alert symbol indicates a potentially hazardous situation which, if not avoided, may result in property damage.

	The torque symbol alerts you to tighten fasteners to a specified torque value.
NOTE:	A Note provides information or suggestions that help you correctly perform a task.

3. SAFE WORKING PRACTICES:

3.1 CAUTION

When handling parts, wear appropriate gloves, eyeglasses, ear protection, and other safety equipment.

3.2 CAUTION

Practice safe lifting procedures. Consider size, shape, and weight of assemblies. Obtain help or the assistance of a crane when lifting heavy assemblies. Make certain the path of travel is clear.

4. INSTALLATION GUIDELINES

4.1 Considerations should be made to route all wiring and airline in protective locations away from any moving parts.

4.2 Cable ties or other fastening devices may be required to secure airline, wire and/or fittings to truck/suspension.

4.3 Apply Permatex #807 or comparable anaerobic pipe thread sealant to fill exterior pipe threads on brass fittings and tighten 1-1/2 revolutions beyond hand tight.

NOTE: The steering lock comes preassembled to the axle. (See figure 1)

5. PLUMBING INSTRUCTIONS

5.1 It is up to the installer to determine necessary valves and plumbing.

NOTE: Link recommends the use of a 4-way air valve similar to Parker valve 410811000. See Figure 3 for port identification.

5.2 Plumb from air supply (valve) to **AIR IN** fitting in Figure 2.

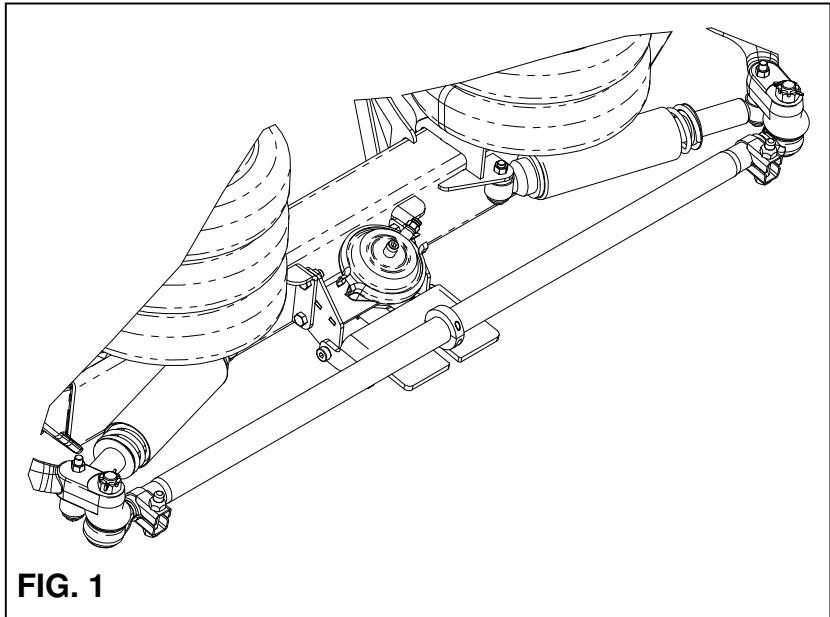

6. FINAL ASSEMBLY AND INSPECTION CHECKLIST

6.1 Verify all fasteners and fittings are installed and are tight.

6.2 Is plumbing installation complete and checked for leaks and proper operation?

6.3 Check for proper clearance around lock and airlines.

6.4 Set the wheels at a steering angle of zero degrees. Verify that the collar on the tie rod properly aligns with the slot in the lock plate. If they do not align, loosen the collar, align with slot and tighten bolts.

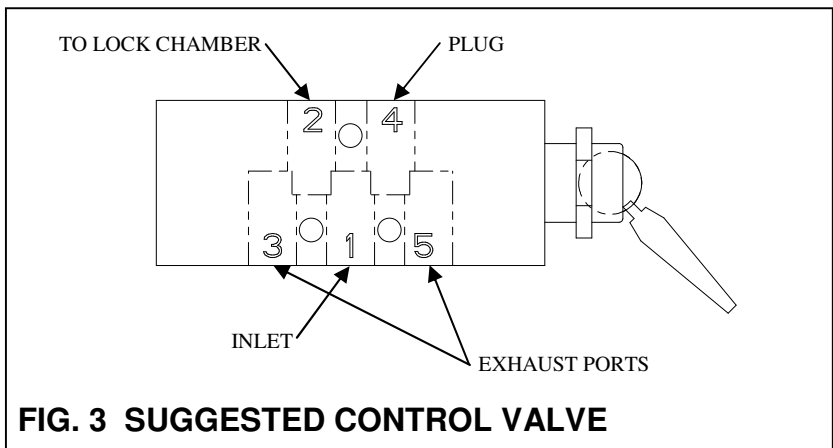
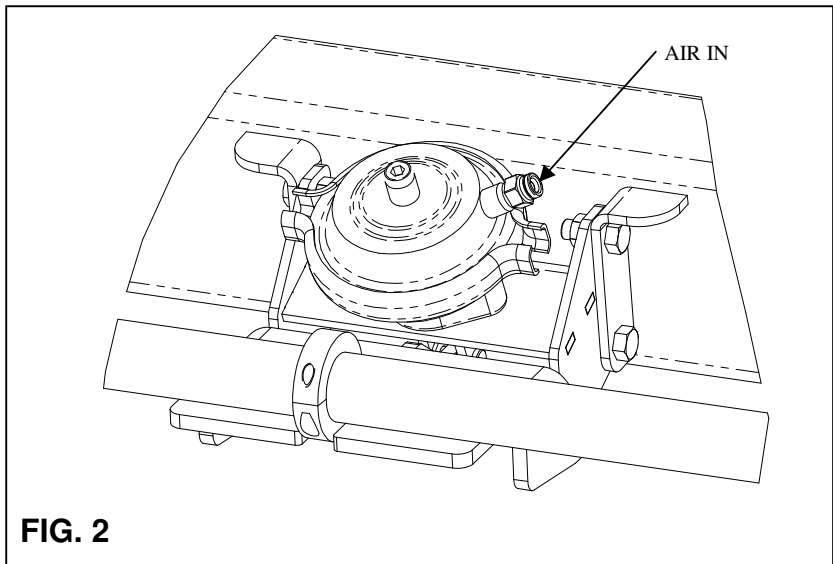

20K DURALIFT II STEERING LOCK KIT (800A0154)

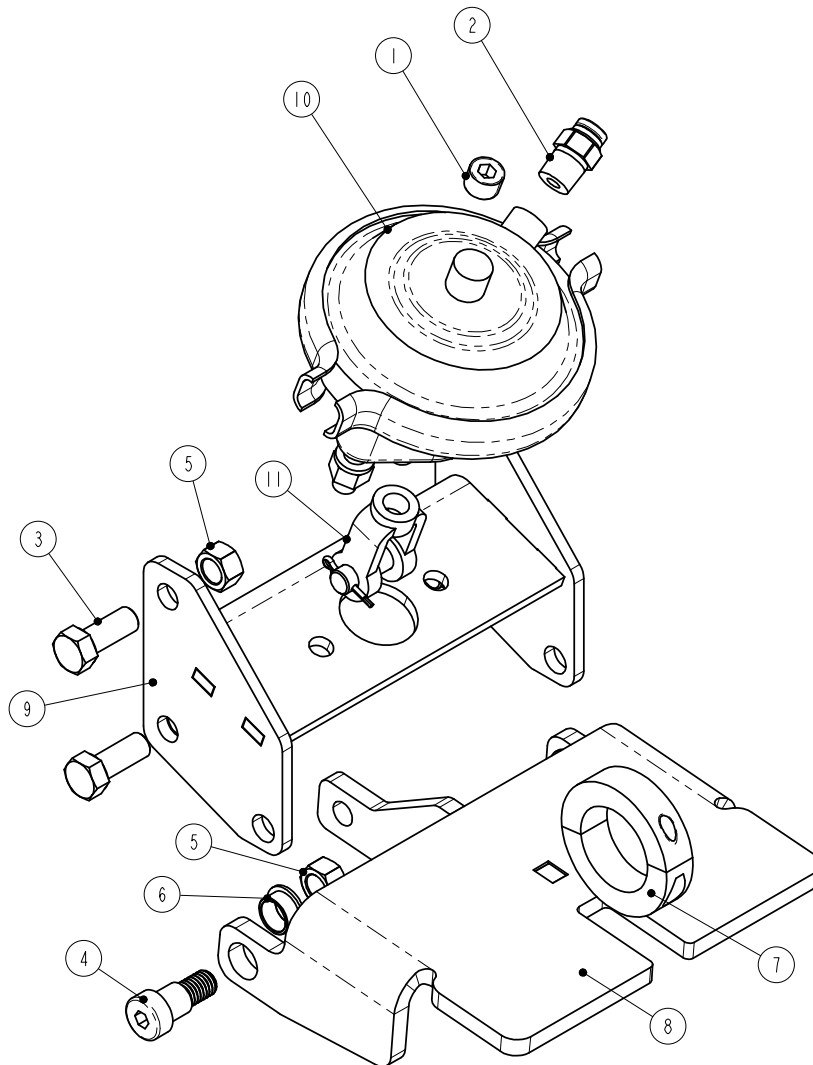

ITEM	PART #	PART DESCRIPTION	800A0154
1	1302-2078	AIR FTG/PLG (3/8 NPT)	1
2	1302-5050	CONNECTOR-MALE, 3/8 TB, 3/8 NPT	1
3	1402-1610	1/2 X 1 1/4 UNC HEX CAP SCR (GR 8)	4
4	14302005	5/8 X 5/8 SHOULDER BOLT	2
5	1476-1601	1/2 UNC HEX TOP LOCK NUT (GR C)	6
6	15000922	BUSHING-PLASTIC, 5/8 X 3/8	2
-	80000233	MANUAL-INSTALLATION, 20K STEERING LOCK KIT	1
7	80001746	COLLAR-SHAFT, CLAMP ON	1
8	800A0155	PLATE-ARM, LOCK	1
9	800A0156	BRACKET-MOUNT, LOCK	1
10	84001637	CHAMBER-SERVICE, TYPE 12	1
11	84001638	CLEVIS-ASSEMBLY	1



LINK MANUFACTURING, LTD.
 223 15TH ST. NE
 SIOUX CENTER, IA 51250
 1-800-222-6283
www.linkmfg.com