

Link

**LIFTABLE
SUSPENSIONS**

Link Mfg. Ltd.
223 15th St. N.E.
Sioux Center, IA USA
51250-2120
www.linkmfg.com

**QUESTIONS?
CALL CUSTOMER
SERVICE
1-800-222-6283**

OWNER'S GUIDE

8A000716 DURALIFT II
8000 LB. CAPACITY

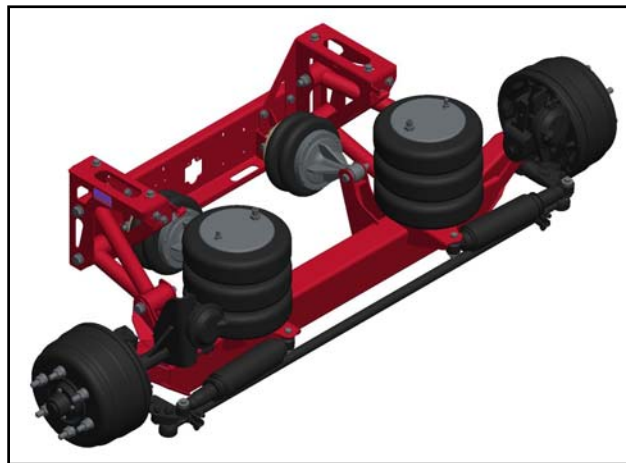

DEALER / INSTALLER: Complete this section and give to vehicle owner.

Serial No: _____
Part No: **8A000716**
Capacity: **8000 lbs.**
Date Installed: _____

Refer to separate Installation Instructions for installation details.

Table of Contents	
1. Introduction	2
2. Axle Identification	3
3. Safety Warnings	3
4. Operation	4-5
5. Maintenance	5-6
6. Troubleshooting	6
7. Warranty	7
8. Parts Lists	8-14

IMPORTANT: PLEASE READ THIS ENTIRE MANUAL BEFORE OPERATING YOUR SUSPENSION AND KEEP IT FOR FUTURE REFERENCE.

1. INTRODUCTION

Thank you for choosing a Link Duralift II liftable suspension. We want to help you to get the best results from the suspension and to operate it safely. This manual contains information to introduce you to the Link Duralift II liftable suspension and to assist you with its operation and maintenance. The manual is intended solely for use with this product.

All information in this manual is based on the latest information available at the time of printing. Link Manufacturing reserves the right to change its products or manuals at any time without notice. Contact Link at (800) 222-6283 or visit www.linkmfg.com for information on recent changes to products.

2. AXLE IDENTIFICATION

The axle identification tag is located on the driver's side of the suspension as shown to the right. The tag contains the suspension part number and a unique serial number.

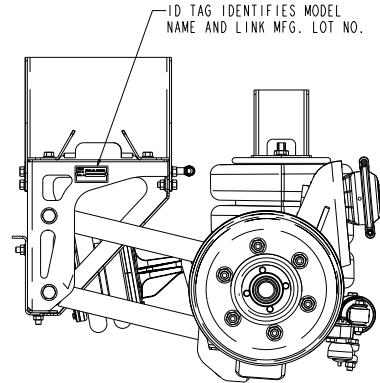

3. SAFETY WARNINGS

⚠ CAUTION

Do not actuate your lift axle when traveling at speeds greater than 15 mph. This could result in component damage.

⚠ CAUTION

Do not exceed 8000 lbs on the lift axle suspension. Failure to heed this warning can result in improper weight distribution or component damage.

⚠ CAUTION

Do not exceed 20 psi in the lift axle's ride springs when the vehicle is unloaded. Failure to heed this warning can result in improper weight distribution or component damage.

4. OPERATION

4.1 Lowering Your Lift Axle

4.1.1 To lower the axle, move the toggle switch to the “Lower” position.

CAUTION

Do not actuate your lift axle when traveling at speeds greater than 15 mph. This could result in component damage.

4.1.2 Use the regulator to adjust the air pressure as on the gauge to the appropriate air pressure for the vehicle load conditions. Refer to chart below for recommended pressures.

8K AIR PRESSURE AXLE LOAD CHART
(For reference only. Use scale to determine actual loads.)

LOAD IN LBS AT GROUND	DURALIFT II PSI
4000	28
5000	37
6000	46
7000	55
8000	64

CAUTION

Do not exceed 20 psi in the lift axle’s ride springs when the vehicle is unloaded. Failure to heed this warning can result in improper weight distribution or component damage.

CAUTION

Do not exceed 8000 lbs on the lift axle suspension. Failure to heed this warning can result in improper weight distribution or component damage.

4. OPERATION (continued)

4.2 Raising Your Lift Axle

4.2.1 To raise the axle, move the toggle switch to the “Raise” position.

CAUTION

Do not actuate your lift axle when traveling at speeds greater than 15 mph. This could result in component damage.

5. MAINTENANCE

After first month or 1,000 miles	<input type="checkbox"/> Check for loose suspension fasteners (Tighten to values given on Torque Table on following page).
Every month or 1,000 miles	<input type="checkbox"/> Check wheel bearing oil level and inspect wheels for leaks (SAE 80W-90 Mineral Based Gear Lube). <input type="checkbox"/> Check suspension for debris rubbing air springs. <input type="checkbox"/> Check for worn steering stabilizer shocks.
Every three months or 2,500 miles	<input type="checkbox"/> Grease camshaft bushings (Multipurpose NLGI 2). <input type="checkbox"/> Check for worn suspension bushings. <input type="checkbox"/> Check for loose suspension fasteners (Tighten to values given on Torque Table on following page). <input type="checkbox"/> Check brake lining wear and replace any cracked, broken or oil soaked linings. <input type="checkbox"/> Inspect brake drums for heat checks, grooves, hot spots, glazing, cracks and out of round and replace if necessary. <input type="checkbox"/> Inspect wheel ends for excessive play.
Every twelve months or 10,000 miles	<input type="checkbox"/> Grease slack adjusters (Multipurpose NLGI 2). <input type="checkbox"/> Replace wheel bearings lubricating oil (SAE 80W-90 Mineral Based or SAE 75W-80 Synthetic Gear Lube). <input type="checkbox"/> Check brake chambers and slack adjusters for proper function and excessive wear. <input type="checkbox"/> Inspect brake rollers, roller shafts, anchor pins and bushings for excessive wear and replace if necessary. <input type="checkbox"/> Check shoes for bent shoe ribs, cracks in shoe table welds and elongated rivet holes and replace if necessary. <input type="checkbox"/> Inspect suspension air controls for proper function and leaks.

5. MAINTENANCE (continued)

TORQUE TABLE

SUSPENSION PIVOT FASTENERS	3/4 UNF	300-320 FT-LBS
FRAME MOUNT FASTENERS	5/8 UNC	160-180 FT-LBS
HANGER FASTENERS	1/2 UNC	90-120 FT-LBS
AIR SPRING NUT	3/4 UNC	40-50 FT-LBS
AIR SPRING NUT	1/2 UNC	20-30 FT-LBS
AIR SPRING BOLT	3/8 UNC	15-20 FT-LBS
LIFT ACTUATOR	5/8 UNF	150-190 FT-LBS

CROSS REFERENCE

COMMON REPLACEMENT PARTS

ITEM	LINK	FIRESTONE	CONTITECH
LIFT AIR SPRINGS	1103-0062		FD 200-25
LOAD AIR SPRINGS	1103-0056	W01-358-7996	161524

6. TROUBLESHOOTING GUIDE

TROUBLE	PROBABLE CAUSE	REMEDY
Axle will not stay up	Loose Air Fittings	Check and retighten.
	Damaged Air Lines	Check for excessive wear. Replace if worn or damaged.
	Damaged or Worn Air Springs	
Punctured Load Air Springs	Other Components too close to Air Spring	Check for clearance all around air spring under full load and deflated. Move anything coming in contact with air springs.
Loose Convolution Ribs	Under Extended Air Springs—Improper ride height	Check for proper ride height. A) Use smaller tires.
Air Spring Separation at End Plates	Over Extended Air Springs—Improper ride height	Check for proper ride height. A) Use bigger tires. B) Lower suspension.
Lift Air Spring Wear or Broken Bumper	Over Extended Load Springs—Crushes lift bag	Check for proper ride height. A) Use bigger tires B) Lower suspension. C) Install over-extension straps.

7. WARRANTY

Link warrants their suspension's fabricated structural components against failure under normal use for a period of three (3) years from date of installation by the original purchaser. Under this warranty Link will replace or repair any part that by its inspection is determined to be defective. In addition, for a period not to exceed one (1) year,* Link will provide a labor allowance, using guidelines, which it determines to be adequate to properly replace or repair defective structural parts and/or components within constraints as noted below.

All parts and components thought to be defective must be returned with company authorization, freight prepaid, to Link. These returns must be accompanied by a complete written explanation of claimed defects and circumstances of failure, the serial number, and date of installation. Labor allowance must be authorized by Link prior to initiation of repairs.

*Purchased components and/or accessories other than the fabricated structure (axle and axle assemblies, air springs, wheel end equipment, brake and brake components, and air control parts) are warranted in accordance with warranty coverage provisions from date of installation.

LIMITATIONS

Link accepts no warranty responsibility for:

- Incidental or consequential damages or loss of time or profits resulting from product failure.
- Damage resulting from owner or operator abuse, misuse or neglect.
- Failure due to improper installation.
- Component parts manufactured by others for Link, beyond those companies' implied or expressed warranty.

This warranty is in lieu of any other warranty, obligation, or liability on the part of Link and no other person is authorized to make any representation or warranties beyond those expressed herein. All implied warranties of fitness and merchantability for any particular purpose are hereby excluded. There are no warranties of fitness which extend beyond the description on the face hereof. This warranty does not apply to failures resulting from improper installation, neglect, accident, misuse or operation beyond the rated capability of the model or the vehicle to which it is attached, nor to any parts which have been altered or repaired without the written consent of Link Manufacturing, Ltd. In no event shall Link be liable for indirect special, incidental or consequential damages of any nature. The foregoing is Link Manufacturing's only warranty, and all other warranties, whether expressed or implied, including, but not limited to, the implied warranties or merchantability or fitness for a particular purpose, are hereby disclaimed.

WARRANTY COVERAGE PROVISIONS

ITEM	MONTHS <i>(WHICHEVER COMES FIRST)</i>	MILEAGE	COVERAGE
MAJOR STRUCTURAL COMPONENTS	UP TO 12	UP TO 100,000	PARTS & LABOR ALLOWANCE
	12-36	100,000-300,000	PARTS ONLY
PIVOT BUSHING	UP TO 12	UP TO 100,000	PARTS & LABOR ALLOWANCE
	12-36	100,000-300,000	PARTS ONLY
AIR CONTROLS	UP TO 12	UP TO 100,000	PARTS & LABOR ALLOWANCE
AIR SPRINGS	UP TO 12	UP TO 100,000	PARTS & LABOR ALLOWANCE
	12-36	100,000-300,000	PARTS ONLY
LINK MANUFACTURED AXLE COMPONENTS	UP TO 12	UP TO 100,000	PARTS & LABOR ALLOWANCE
	12-36	100,000-300,000	PARTS ONLY
OTHER SUSPENSION AND BRAKE COMPONENTS	WARRANTY AS PROVIDED BY THE ORIGINAL EQUIPMENT MANUFACTURER		

Defective or damaged components should be returned to Link with a pre-arranged Returned Goods Authorization (RGA) number through the Customer Service Department. The damaged or defective component may then be replaced if in compliance with warranty conditions.

8K (8A000716) DURALIFT II SELF-STEER

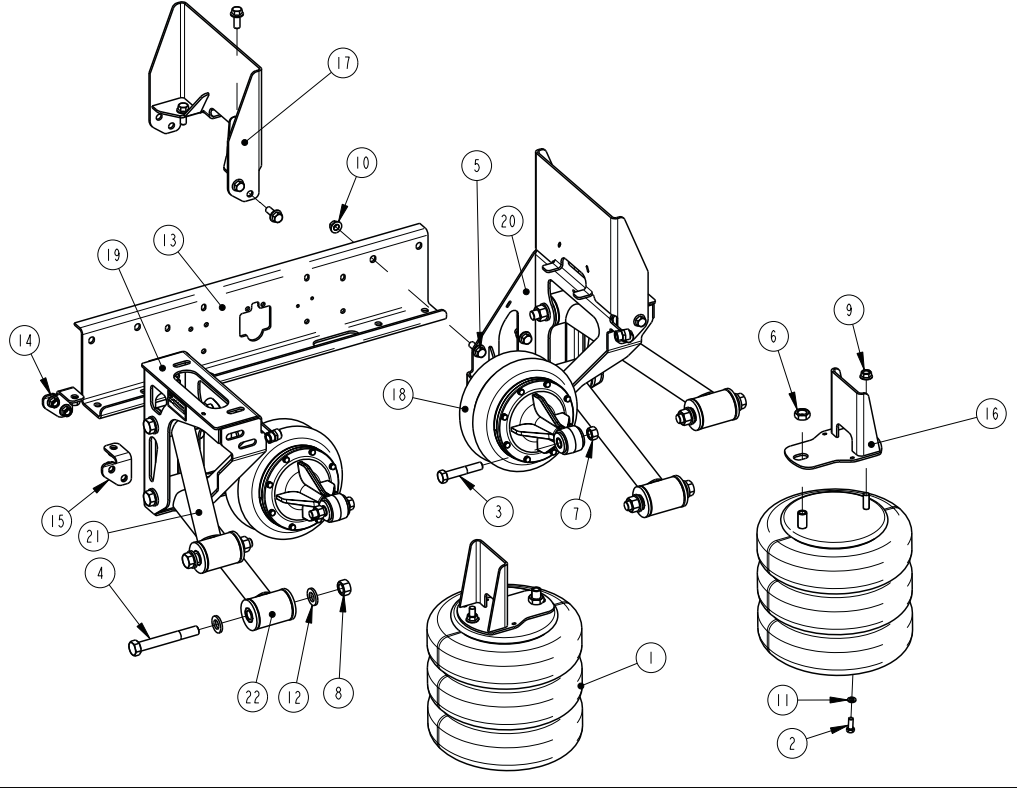

8K (8A000716) DURALIFT II SELF-STEER

ITEM	PART NUMBER	DESCRIPTION	QTY
1	11030056	SPRING-AIR	2
2	140B-1208	3/8 X 1 UNC HEX CAP SCR (GR 8) O&P	4
3	140D-2028	5/8 X 3 1/2 UNF HEX CAP SCR (GR 8) O&P	4
4	140D-2446	3/4 X 5 3/4 UNF HEX CAP SCR (GR 8) O&P	8
5	141A-1610	1/2 X 1 1/4 UNC FLANGE BOLT (GR 8) O&P	20
6	1475-2402	3/4 UNF HEX JAM NUT, O&P	2
7	1477-2006	5/8 UNF HEX TOP LOCK NUT (GR C) O&P	4
8	1477-2406	3/4 UNF HEX TOP LOCK NUT (GR C) O&P	8
9	1480-1600	1/2 UNC SERRATED FLANGE NUT	2
10	1480-1604	1/2 UNC TOP LOCK FL NUT (GR G) O&P	8
11	1485-1200	3/8 LOCK WASHER	4
12	14882402	3/4 HARDENED WASHER, ZINC PLATED	16
13	80002109	CROSSMEMBER-DURALIFT2	1
14	800A0120	BRACKET-MOUNT, FASTENER	2
15	800A0121	BRACKET-MOUNT, FASTENER	2
16	800A0122	BRACKET-MOUNT, AIRSPRING	2
17	800A0126	BRACKET-MOUNT, FRAME	2
18	800A0309	ACTUATOR-SPRING, LIFT	2
19	810A0096	BRACKET-HANGER, SUSPENSION	1
20	810A0097	BRACKET-HANGER, SUSPENSION	1
21	820A0033	ARM-CONNECTING	2
22	820A0084	ARM-CONNECTING	2

Notes:

- Multiple options exist—call for details.

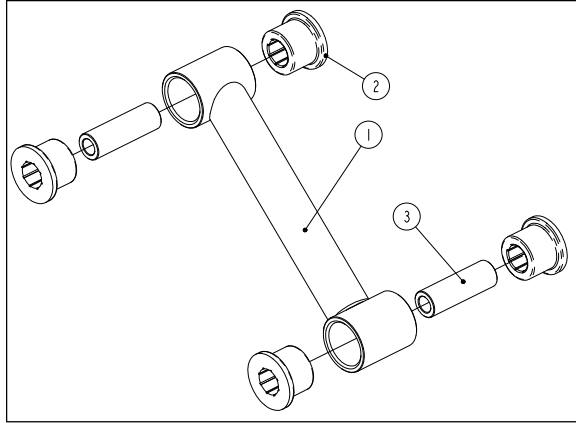

BILL OF MATERIALS FOR ASSEMBLY: 820A0033			
ITEM	PART NUMBER	DESCRIPTION	QTY
1	820A0036	ARM-CONNECTING	1
2	15000890	BUSHING	4
3	80001210	TUBE-BUSHING	2

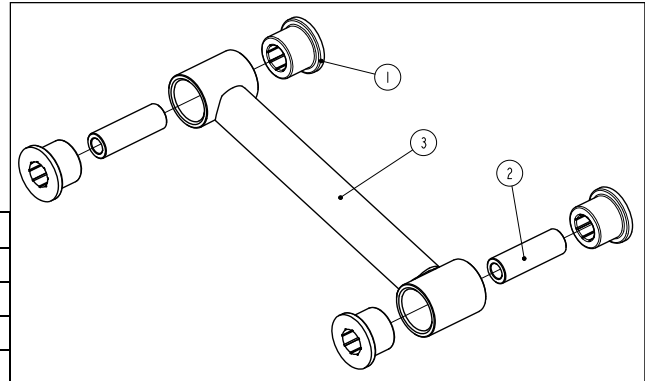

BILL OF MATERIALS FOR ASSEMBLY: 820A0084			
ITEM	PART NUMBER	DESCRIPTION	QTY
1	15000890	BUSHING	4
2	80001210	TUBE-BUSHING	2
3	820A0083	ARM-CONNECTING	1

BILL OF MATERIALS FOR ASSEMBLY: 800A0309

ITEM	PART NUMBER	DESCRIPTION	QTY
1	11030062	SPRING-AIR	1
2	1302-5104	ELBOW-3/8 TB, 1/4 M-NPT	1
3	1401-0808	1/4 X 1 UNC HEX CAP SCR (GR 5)	16
4	1485-0800	1/4 LOCK WASHER	16
5	15000846	BUSHING	4
6	15000891	STOP-BUMPER, CYL.	1
7	15000932	BEARING-LINEAR	2
8	80000835	TUBE-BUSHING	2
9	80001328	RING-RETAINER, AIRSPRING	4
10	80002243	PISTON-CYL., AIR	1
11	80002244	ROD-SUPPORT	1
12	80002245	CAP-CYL., AIR	1

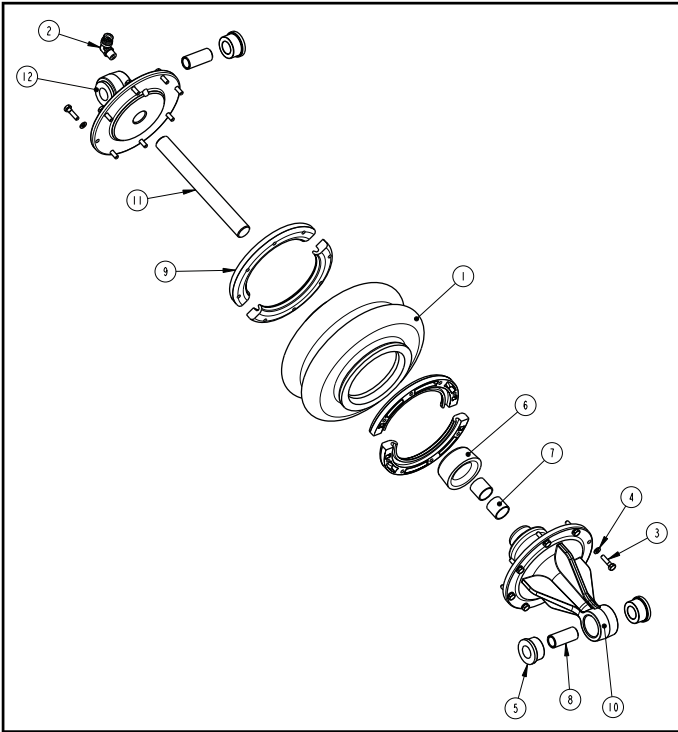

8K DURALIFT II SELF-STEER AXLE ASSEMBLY BILL OF MATERIAL (830A0308)

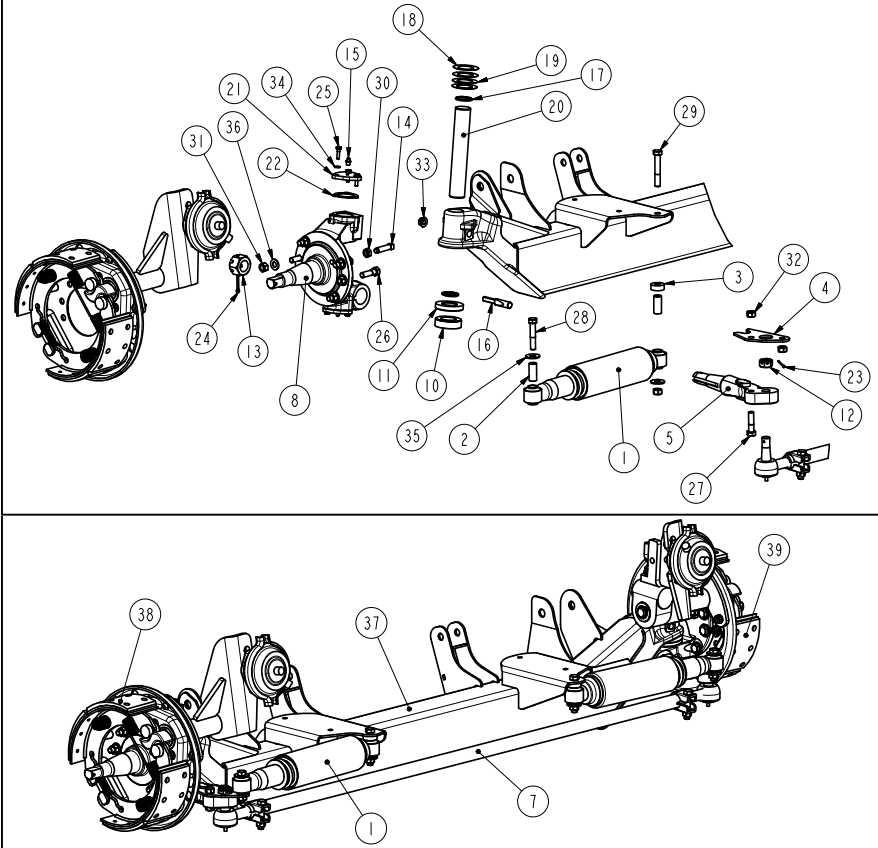

8K DURALIFT II SELF-STEER AXLE ASSEMBLY BILL OF MATERIAL (830A0308)

ITEM	PART NUMBER	DESCRIPTION	QTY	ITEM	PART NUMBER	DESCRIPTION	QTY
1	12100012	SHOCK ABSORBER, WIDE BODY	2	21	84001991	CAP-KNUCKLE	4
2	80000009	BUSHING-SHOCK, ACETAL	4	22	84001992 *	GASKET-CAP, KING PIN	4
3	83000079	SPACER-MOUNT, SHOCK	2	23	84001995	PIN-COTTER, .13 X 1.75	2
4	83000096	PLATE-MOUNT, SHOCK	2	24	84001996	PIN-COTTER, .18 X 2.00	2
5	83000097	ARM-STEERING, 8K	1	25	1401-0808	1/4 X 1 UNC HEX CAP SCR (GR 5)	12
6	83000098	ARM-STEERING, 8K (Not Shown)	1	26	1402-1614	1/2 X 1 3/4 UNC HEX CAP SCR (GR 8)	12
7	84001034	TIE ROD ASSEMBLY	1	27	140D-1616	1/2 X 2 UNF HEX CAP SCR (GR 8) O&P	2
8	84001233	KNUCKLE, 8K (LEFT)	1	28	140D-1622	1/2 X 2 3/4 UNF HEX CAP SCR (GR 8) O&P	2
9	84001234	KNUCKLE, 8K (RIGHT) (Not Shown)	1	29	140D-1626	1/2 X 3 1/4 UNF HEX CAP SCR (GR 8) O&P	2
10	84001433 *	BEARING-THRUST	2	30	1474-1600	1/2 UNC HEX JAM NUT	2
11	84001434 *	CAP-BEARING	2	31	1476-1601	1/2 UNC HEX TOP LOCK NUT (GR C)	12
12	84001697	NUT-HEX, SLOTTED, .75	2	32	1477-1606	1/2 UNF HEX TOP LOCK NUT (GR C) O&P	6
13	84001698	NUT-HEX, SLOTTED, 1.13	2	33	1480-1404 *	7/16 UNC TOP LOCK FL NUT (GR G) O&P	2
14	84001699	BOLT-STOP, STEERING	2	34	1487-0600	3/16 TYPE A PLAIN WASHER	12
15	84001901	FITTING-GREASE	4	35	1487-1600	1/2 TYPE A PLAIN WASHER	4
16	84001928 *	PIN-DRAW, LOCKING	2	36	1488-1602	1/2 SAE HARDENED WASHER	24
17	84001987 *	SEAL-KNUCKLE	4	37	830A0307	AXLE-FAB., 8K DURALIFT2	1
18	84001988 *	SHIM (.005)	4	38	84001612	BRAKE ASSY-L	1
19	84001989 *	SHIM (.010)	4	39	84001613	BRAKE ASSY-R	1
20	84001990 *	PIN-KING, 8K	2				

* Items included in Kingpin Kit 84001933

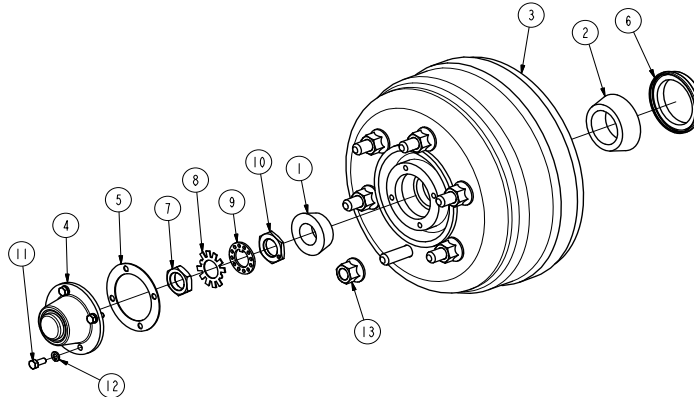

BILL OF MATERIALS FOR HUB AND DRUM PARTS

ITEM	PART NUMBER	DESCRIPTION	QTY
1	84001406	BEARING-ROLLER, CONE	1
2	84001407	BEARING-ROLLER, CONE	1
3	84001508	HUB & DRUM-FN, 12.8 X 4	1
4	84002001	CAP, HUB	1
5	84002002	GASKET-CAP, HUB	1
6	84002003	SEAL-OIL	1
7	84002004	NUT-WHEEL BEARING, OUTER	1
8	84002005	WASHER-STAR	1
9	84002006	WASHER-LOCK	1
10	84002007	NUT-WHEEL BEARING, INNER	1
11	1401-1006	5/16 X 3/4 UNC HEX CAP SCR (GR 5)	4
12	1485-1004	5/16 LOCK WASHER OIL&PHOS	4