

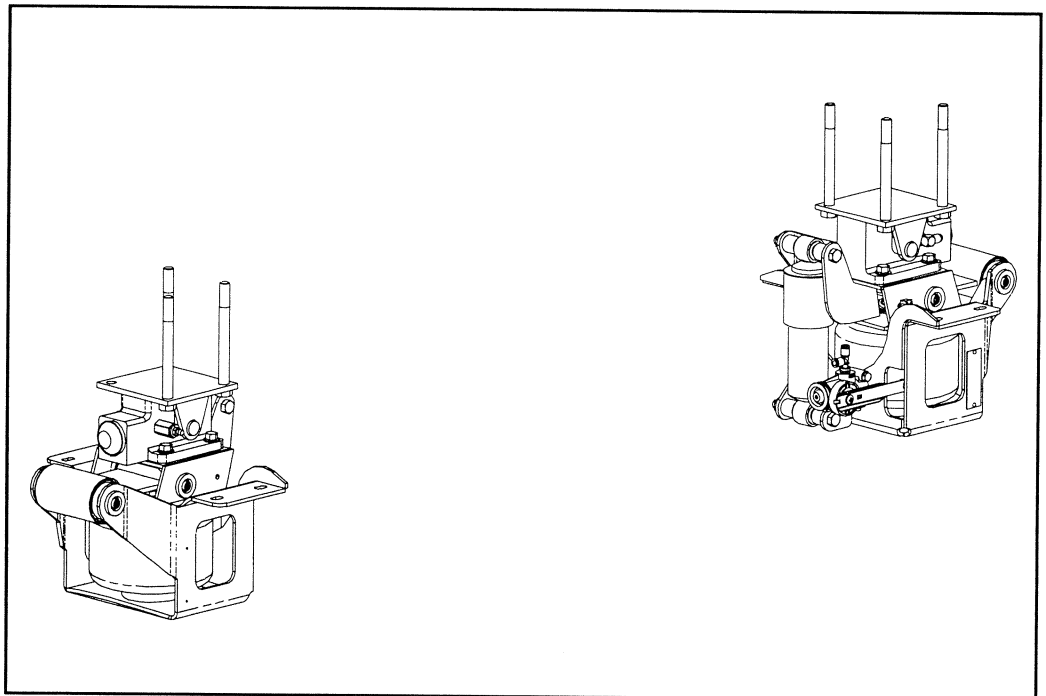

INSTALLATION INSTRUCTIONS PARTS LIST

NAV9876 (2492-A000) & NAV9876-RC (2492-R000)



Link Mfg. Ltd.
223 15th St. N.E.
Sioux Center, IA USA
51250-2120

(712) 722-4874
Fax (712) 722-4876

**QUESTIONS?
CALL CUSTOMER
SERVICE
1-800-222-6283**

The **CABMATE MODEL NAV9876** fits Navistar 9670, 9700 and 9800 Cabovers with 89 and 110 inch cabs built after 1981. It replaces the original upper and lower latch brackets, Navistar part no. 503787C1 and 503751C94.

UNIT WEIGHT: 69.8 LB.

NET WEIGHT ADDED: 16.2 LB.

CABMATE MODEL NAV9876

Review the Parts List on page 3 to become familiar with the different components of the CABMATE.

IMPORTANT: Due to many chassis variables caused by installation of special equipment or options, the fit of the NAV9876 CABMATE may be affected and should be evaluated before beginning installation.

IMPORTANT: After the CABMATE is installed, the cab of the truck must be free to move. Before raising the cab to begin installation, check clearances between the cab and any objects the cab may contact when it moves downward or to the rear. Two inches of clearance should be sufficient.

A. Relocating of a Power Steering Reservoir, Air Dryer and Junction Box may be required before beginning installation, see below for more information.

B. Raise the cab and remove the hydraulic latch from the cab, and the lower latch brackets from the aluminum cross channels. **NOTE:** Save the original mount bolts of the lower latch brackets for later use (Fig. 1).

C. With the Height Control Valve on the passenger side, loosely fasten both halves of the CABMATE crossmember mount brackets to the aluminum cross channels using the original mount bolts.

D. Securely mount the Cab Mount Brackets (No. 31 on the parts list) to the sill of the cab using the 1/2" bolts (No. 16 on the parts list).

E. The hydraulic lines for the cab latch will need to be rerouted to the unit bottoms using the hose kit (No. 8,9 and 10 on the parts list). Disconnect the original coupling and tie up, or remove the old lines. Route the new lines from the coupling of the rear port of the passenger side latch. Connect the two front ports of the latches together. **NOTE:** Assure all lines have enough loop to allow ends to move freely with the cab latches.

F. Lower the cab until the latches almost contact the latching pins. Laterally align the unit bottoms directly below the latching pins. Lower the cab until the latches completely engage and tighten the original mount bolts. **SECURELY TIGHTEN ALL FASTENERS.**

G. Affix the cylinder warning decal that is included with this instruction, to a location clearly visible from the cab tilt controls.

H. See page 2 for plumbing instructions and height adjustments.

For CABMATE Plus Model NAV9876-RC, refer to page 1A and 1B for additional installation steps.

IMPORTANT: To ensure proper CABMATE operation adjust the cylinder until the cylinder pin is approximately in the center of the slot, with the cab at proper operating height. To accomplish this, adjust the tilt cylinder so that the cylinder pin touches each end of the slot and mark the two locations (Fig. 2). Adjust the cylinder pin until it is halfway between the two marks. **THE CYLINDER PIN LOCATION SHOULD BE CHECKED EVERY TIME THE CAB IS LOWERED.**

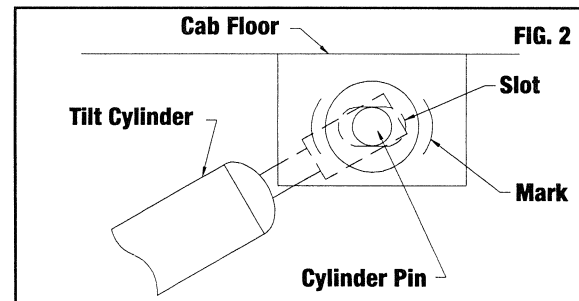
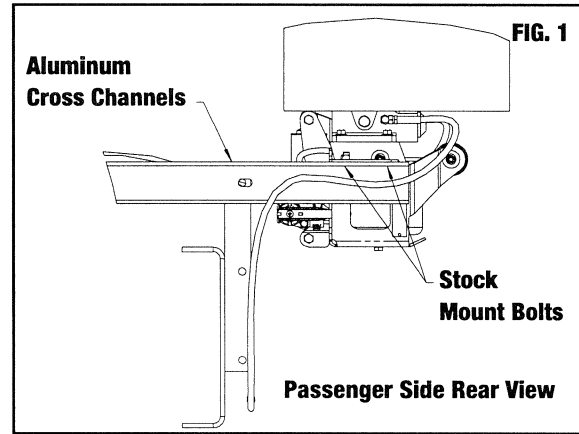

POWER STEERING RESERVOIR RELOCATION

A. To relocate the power steering reservoir remove the reservoir and the two "L" shaped brackets from the aluminum cross channels.

B. Reposition the brackets on the front cross channel with the "L", pointing down. Reattach the reservoir to the "L" brackets (Fig. 3).

C. Loosen the reservoir mount straps and slide the reservoir down so the cab will not come in contact when it moves through its travel.

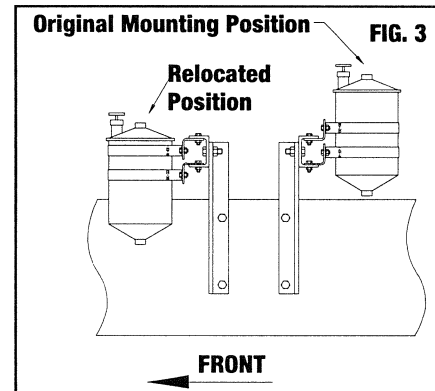

JUNCTION BOX RELOCATION

A. Remove the junction box from the battery box. Reroute the wiring harness from around the outside of the aluminum cross channels. **NOTE:** Save the original mount bolts for later use.

B. Fasten the relocation bracket to the battery box using the 1/4" mounting hardware (No. 12, 19, 23, and 24 on the parts list).

C. Fasten the junction box to the relocation bracket using the original mount bolts (Fig. 4).

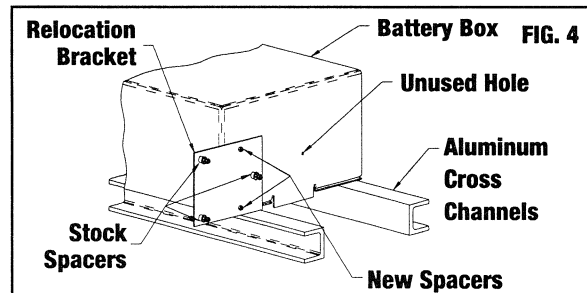

AIR DRYER RELOCATION

A. Remove the air dryer and original mount bracket. **NOTE:** Save the original mount bolts for later use.

B. Mount the Air Dryer Mount Bracket (No. 29 on the parts list) to the frame using original mount bolts.

C. Remount the air dryer to the Air Dryer Mount Bracket using original mount bolts. **NOTE:** This bracket will cause some air dryers to drop more than others, make sure there is adequate space.

PLUMBING INSTRUCTIONS

WARNING: FOR SAFETY PURPOSES THE CABMATE MUST BE SUPPLIED FROM A PRESSURE PROTECTED CIRCUIT. IN THE EVENT OF AN AIR LEAK IN THE CAB SUSPENSION, FAILURE TO PROVIDE A PRESSURE PROTECTED CIRCUIT MAY CAUSE LOSS OF AIR PRESSURE TO VITAL SYSTEMS ON THE VEHICLE.

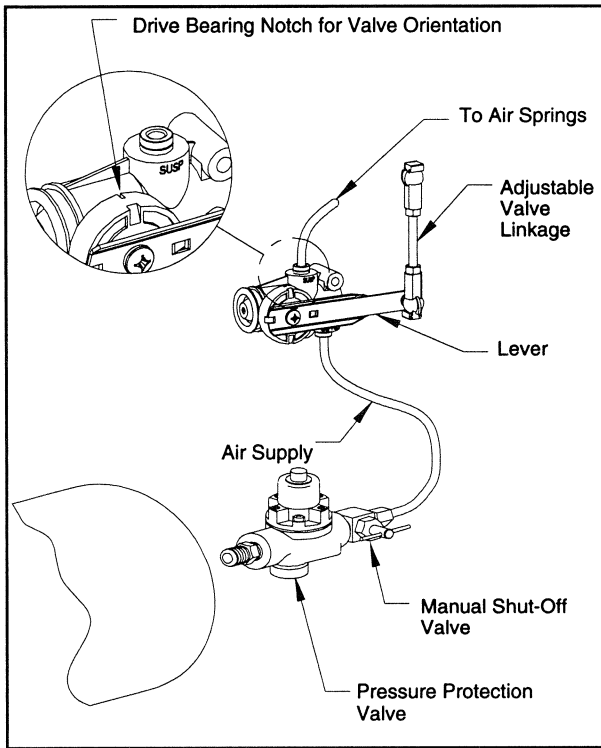

WARNING: LOSS OR APPLICATION OF AIR PRESSURE TO CABMATE WILL CAUSE SUDDEN MOVEMENT OF THE CAB. PRIOR TO INSTALLING OR PERFORMING ANY MAINTENANCE, BLOCK UP THE CABMATE TO PREVENT THE POSSIBILITY OF INJURY.

WARNING: CONNECT THE CABMATE DIRECTLY TO THE MAIN AIR TANK. YOU WILL NEED AN AIR PRESSURE PROTECTION VALVE IN THE LINE. (INCLUDED IN THE PRESSURE PROTECTION KIT, LINK MFG. PART NO. 1350-0000). DO NOT USE AN AIR PRESSURE REGULATOR!

A. With the tank at 0 p.s.i., remove the existing plug or fitting from the desired port.

B. Apply joint compound to the fittings and install the pressure protection kit. **DO NOT USE TEFLON TAPE.** Be sure that the arrows on the valve are pointing in the direction of air flow and the vent hole is pointed down. NOTE: Additional fittings/reducers may be required to attach the hex nipple to the main air tank.

C. Run the 1/4" airline from the shut-off valve to the CABMATE. Be sure that the airline has enough clearance so that there are no pinch points that may restrict or cut the airline. Secure the airline using the cable ties supplied by Link Mfg.

D. Tighten all plumbing fittings. Then, with the system at operating pressure (90 to 110 p.s.i), open the Manual Shut-off Valve to supply air to the CABMATE. Check the system for air leaks.

E. Check for proper operation of the height control valve. Disconnect the valve linkage from the lever. Push the lever down 45°, air should flow into the air spring(s). Return the lever to the neutral position. Push the lever up 45°, air should exhaust from the air spring(s). Return the lever to the neutral position; no air should flow. Reconnect the valve linkage to the lever.

the neutral position. Push the lever up 45°, air should exhaust from the air spring(s). Return the lever to the neutral position; no air should flow. Reconnect the valve linkage to the lever.

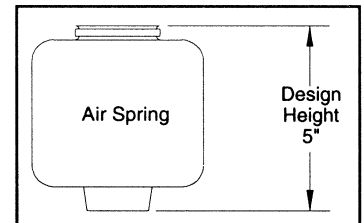

HEIGHT ADJUSTMENTS

Measure the design height of the air spring(s). The height should be 5 inches ± 1/8. To change the height, disconnect one end of the valve linkage and adjust accordingly. Tighten the lock nuts on the valve linkage.

MAINTENANCE

CABMATES need no lubrication and little maintenance. The following components should be checked at the time the truck is being serviced. However, immediate corrective action should be taken if a serious malfunction occurs.

COMPONENT	POSSIBLE PROBLEM	CORRECTIVE ACTION	TORQUE
Airlines	Air leaks	Replace airline	Compression Nut Hand Tight + 1 Turn
Fittings	Air leaks	Remove fitting and apply fresh joint compound. Reinstall fitting, but Do Not Overtighten. Do not use Teflon tape.	Threaded into: Metal Plastic 15 Hand Tight Ft. Lbs. + 1 Turn
Air Springs	A. Improper height B. Air leakage	A. Adjust valve linkage to maintain proper air spring height. B. Replace air spring.	Size Metal Plastic 3/8 25 Ft. Lbs 4 Ft. Lbs 1/2 28 Ft. Lbs 10 Ft. Lbs 3/4 30 Ft. Lbs 10 Ft. Lbs
Height Control Valve*	Air spring(s) will not inflate when weight is added to the cab; OR Air spring(s) will not deflate when weight is removed from the cab.	A. Inspect valve to insure drive bearing notch is located on "SUSP" port side of valve. If not, loosen lever screw (but do not remove completely) and pull lever loose from drive bearing, rotate drive bearing until the drive bearing notch is in the correct position and resecure lever by tightening lever screw. B. Replace Valve.	1/4 Mount Fasteners 10 Ft. Lbs. Bearing Screw 40-50 In. Lbs.
Shock Absorber	Insufficient dampening effect	Replace shocks	45 Ft. Lbs.
Hinge Arm	A. Loose nuts on hinge arm bolts. B. Worn bushings	A. Tighten securely. B. Replace hinge arm.	25 Ft. Lbs.

IMPORTANT: Periodically check the tightness of all fasteners.

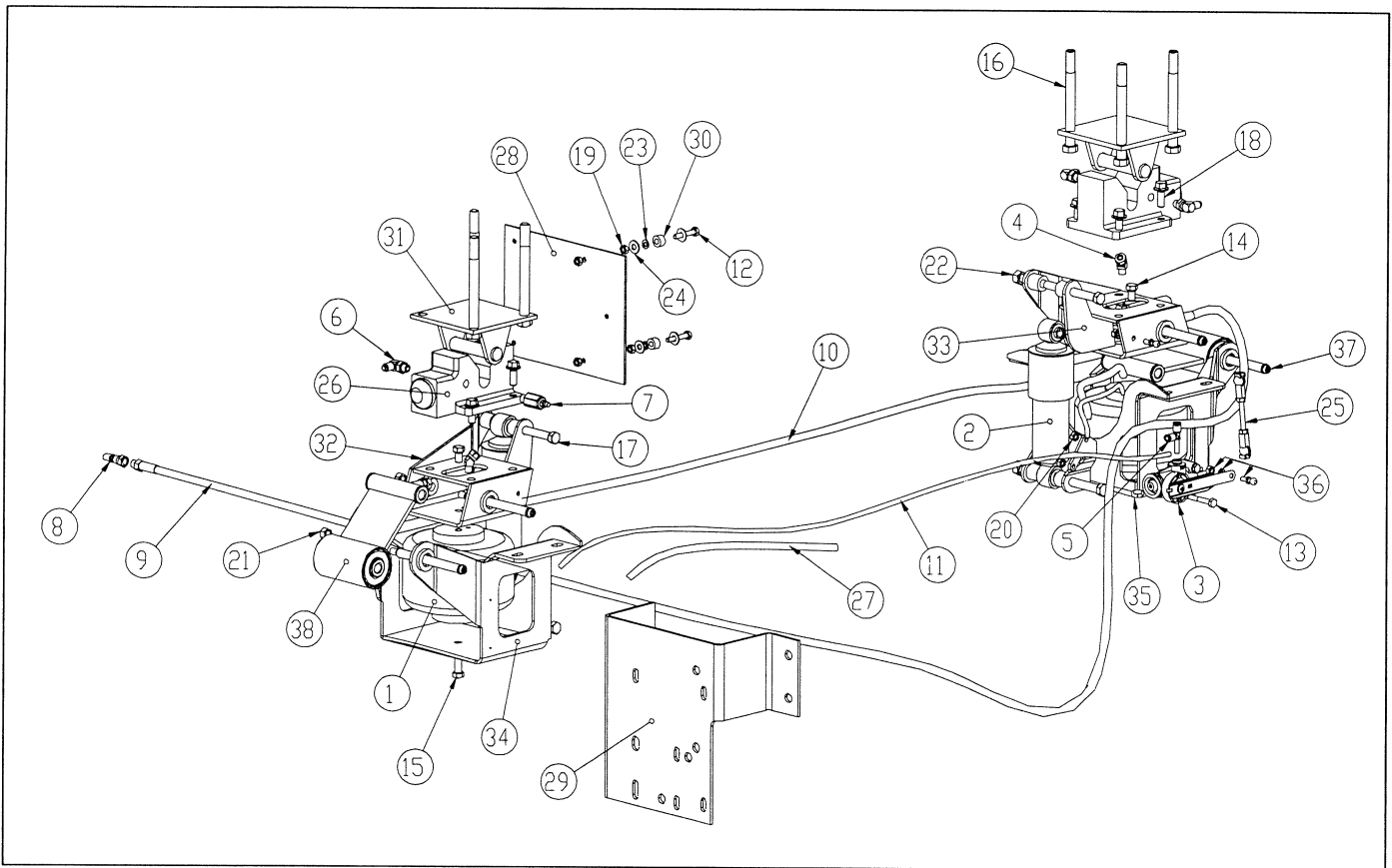

CABMATE® MODEL NAV9876

PARTS LIST

ITEM #	PART #	PART DESCRIPTION	QTY.	ITEM #	PART #	PART DESCRIPTION	QTY.
1	1102-0075	Airspring	2	20	1476-0800	1/4 UNC Hex Center Lock Nut (Grade B)	2
2	1202-0054	Shock Absorber	2	21	1476-1201	3/8 UNC Hex Top Lock Nut (Grade C)	4
3	1350-0101	Assembly-Height Control Valve	1	22	1477-1400	7/16 UNF Hex Center Lock Nut (Grade B)	4
4	1302-4018	Elbow 45, 1/4 TB 1/8 M-NPT, DOT	2	23	1485-0800	1/4 Lock Washer	2
5	1302-5497	Run Tee, 1/4 TB 1/4 PTC, Push-In DOT	1	24	1487-0800	1/4 Type A Plain Washer	4
6	1302-9994	45° Elbow, 1/4 TB, Hyd.	3	25	1500-0246	Linkage-Valve, Height Control (4.00)	1
7	1302-9996	Valve-Bleeder	1	26	1500-0690	Latch-Cab, Hydraulic	2
8	1302-9997	Coupling-Nipple, Hyd.	1	27	1500-0435	.25 Loom-Corrugated	1.8'
9	1302-9998	Hose-High Pressure	1	28	2492-0025	Bracket,Magnetic Switch	1
10	1302-9999	Hose-High Pressure	1	29	2492-0026	Bracket-Mount, Air Dryer	1
11	1302-0090	.250 Airline	5.6'	30	2492-0027	Spacer, Bracket	2
12	1401-0812	1/4 X 1 1/2 UNC Hex Cap Screw (Grade 5)	2	31	2492-5001	Bracket-Mount, Cab	2
13	1401-0814	1/4 X 1 3/4 UNC Hex Cap Screw (Grade 5)	2	32	2492-5013	Bracket-Mount, Latch	1
14	1401-1205	3/8 X 5/8 UNC Hex Cap Screw (Grade 5)	2	33	2492-5014	Bracket-Mount, Latch	1
15	1401-1208	3/8 X 1 UNC Hex Cap Screw (Grade 5)	2	34	2492-5023	Bracket-Mount, Crossmember	1
16	1401-1644	1/2 X 5 1/2 UNC Hex Cap Screw (Grade 5)	6	35	2492-5024	Bracket-Mount, Crossmember	1
17	1403-1432	7/16 X 4 UNF Hex Cap Screw (Grade 5)	4	36	2991-0026	Kit-Pivot Ball	1
18	1411-1208	3/8 X 1 UNC Flange Bolt (Grade 8)	8	37	2990-0502	Bolt-Hinge Arm (4.75)	4
19	1470-0800	1/4 UNC Hex Nut (Grade B)	4	38	2992-2005	Arm-Hinge, Type A (5.000)	2
				Not Shown	1350-0000	Pressure Protection Kit	1