

INSTALLATION INSTRUCTIONS

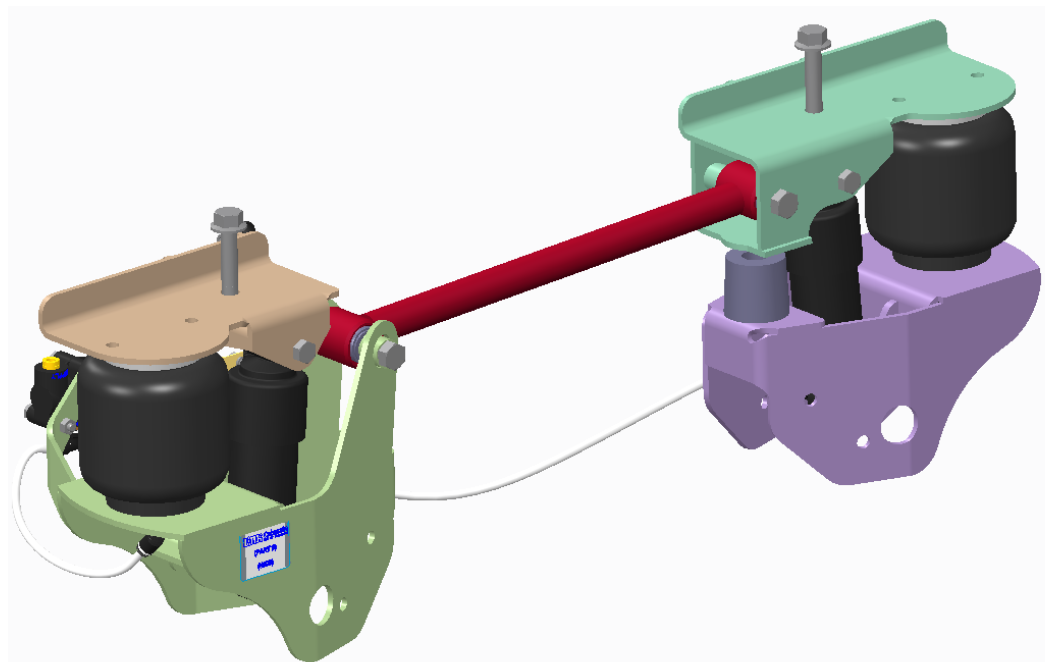

FH1322-A (2175-B000)



The **CABMATE MODEL FH1322-A** fits most 8500 and 9500 series Ford/ Sterling 113" and 122" BBC Conventional Tractors. It replaces the original rear cab supports, Ford/Sterling Part No. F6HT-5A356-BA and F6HT-5B362-AC or F6HZ-5C-038EB and F6HZ-CC-18A160.

(This unit is not compatible with Tractors equipped with a horizontal muffler and vertical cab mounted exhaust.)

UNIT WEIGHT: 35.0 LB.

NET WEIGHT ADDED: 15.0 LB.

Link Mfg. Ltd.
223 15th St. N.E.
Sioux Center, IA USA
51250-2120

(712) 722-4874

www.linkmfg.com

**QUESTIONS?
CALL CUSTOMER
SERVICE
1-800-222-6283**

CABMATE[®] MODEL FH1322-A

Review the Parts List on page 3 to become familiar with the different components of the CABMATE.

IMPORTANT: Due to many chassis variables caused by installation of special equipment or options, the fit of the FH1322-A CABMATE may be affected and should be evaluated before beginning installation.

IMPORTANT: Installation of the CABMATE system will allow the cab to move freely. Before starting installation, check clearances between the cab and any objects the cab may contact when it moves (1 1/2 inches of clearance should be sufficient). The clearance of components that are affected by cab movement, such as exhaust and radiator systems, must also be evaluated.

- A. Remove the top mount bolts from the stock mounts. Securely prop up the cab and remove the rear cab supports. **NOTE:** Save bottom stock mount bolts for later use (Fig. 2)
- B. Slide the unit halves of the CABMATE between the crossmember and the frame. Loosely fasten the Crossmember Mount Brackets to the Crossmember using the stock mount bolts (Fig. 2). Loosely fasten the Cab Mount Brackets to the cab using the 1/2" mounting hardware (Item No. 13 on the parts list).
- C. Install Lateral Control Rod using the 1/2" mounting hardware (Item Nos. 8, 15, 16 and 21 on the parts list). **NOTE:** This may require loosening the front cab mounts to align the back of the cab. **SECURELY TIGHTEN ALL FASTENERS.** Lower the cab completely.
- D. See page 2 for plumbing instructions and height adjustments.
- E. **IMPORTANT:** After plumbing and height control adjustments are completed, temporarily adjust the CABMATE to its maximum upward position. There must be a minimum of 1/4" gap between the cab and the hood. Adjust the hood hinge forward as necessary (Fig. 3).

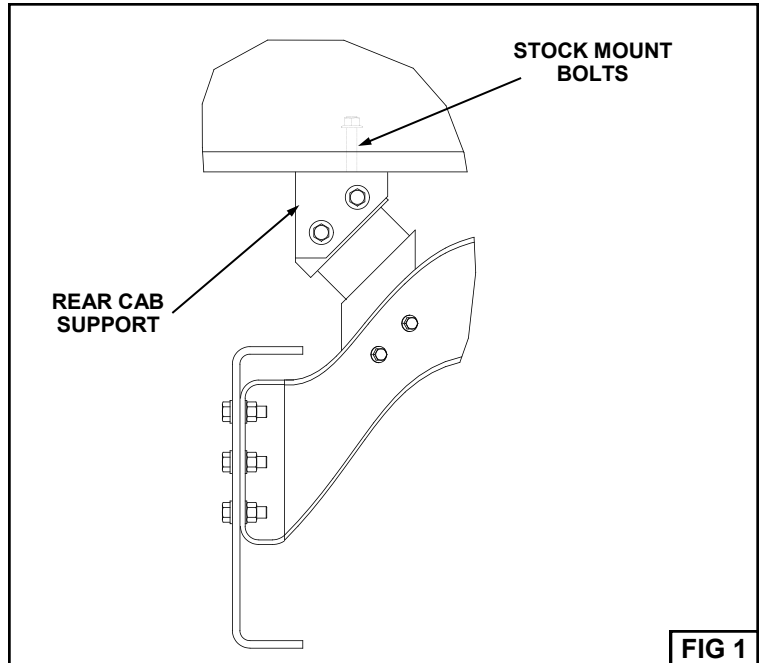

FIG 1

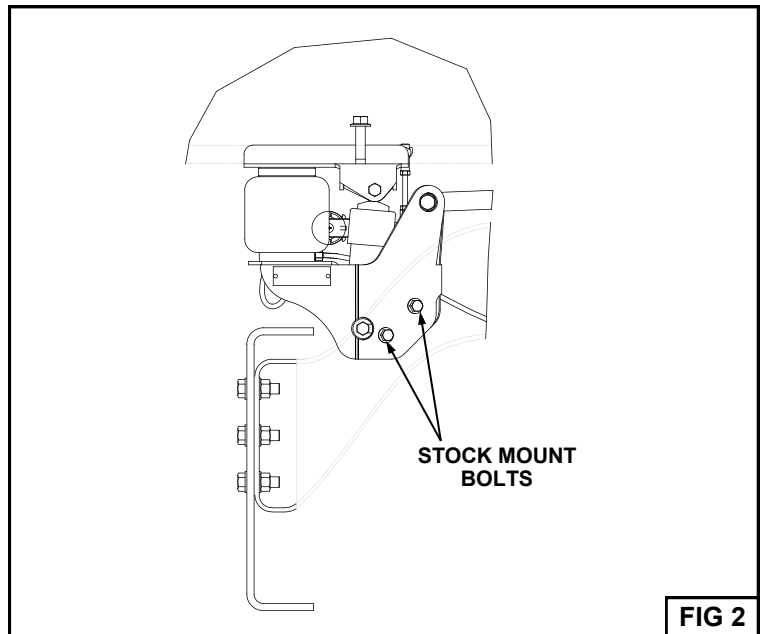

FIG 2

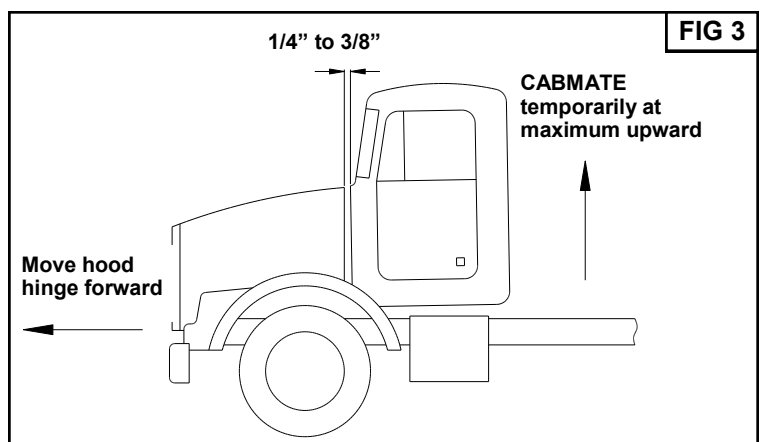
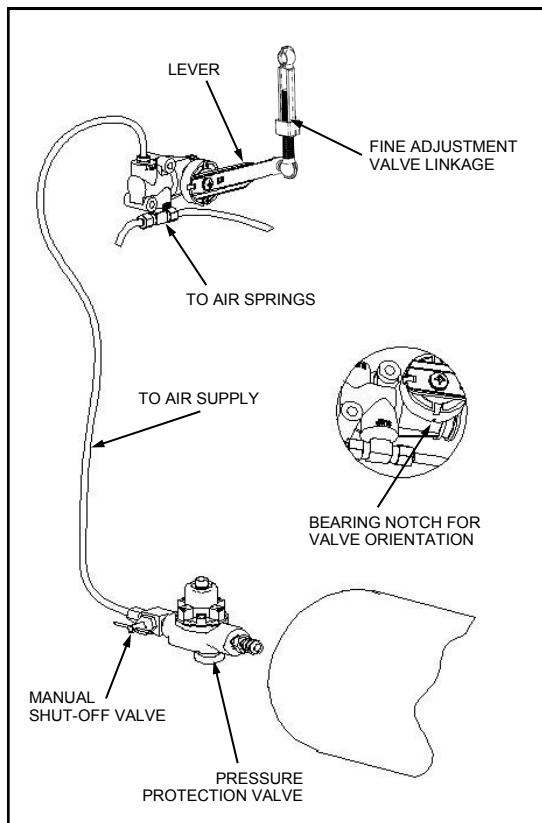

FIG 3

PLUMBING INSTRUCTIONS

WARNING: FOR SAFTY PURPOSES THE CABMATE MUST BE SUPPLIED FROM A PRESSURE PROTECTED CIRCUIT. IN THE EVENT OF AN AIR LEAK IN THE CAB SUSPENSION, FAILURE TO PROVIDE A PRESSURE PROTECTED CIRCUIT MAY CAUSE LOSS OF AIR PRESSURE TO VITAL SYSTEMS ON THE VEHICLE.



WARNING: LOSS OR APPLICATION OF AIR PRESSURE TO CABMATE WILL CAUSE SUDDEN MOVEMENT OF THE CAB. PRIOR TO INSTALLING OR PERFORMING MAINTENANCE, BLOCK UP THE CABMATE TO PREVENT THE POSSIBILITY OF INJURY.

WARNING: CONNECT THE CABMATE DIRECTLY TO THE MAIN AIR TANK. YOU WILL NEED AN AIR PRESSURE PROTECTION VALVE IN THE LINE. (INCLUDED IN THE PRESSUREPROTECTION KIT. LINK MFG. PART NO. 1350-0000). DO NOT USE AN AIR PRESSURE REGULATOR!

A. With the tank at 0 p.s.i., remove the existing plug or fitting from the desired port.

B. Apply joint compound to the fittings and install the pressure protection kit. DO NOT USE TEFLON TAPE. Be sure that the arrows on the valve are pointing in the direction of air flow and the vent hole is pointed down. NOTE: Additional fittings/reducers may be required to attach the hex nipple to the main air tank.

C. Run the 1/4" airline from the shut-off valve to the CABMATE. Be sure that the airline has enough clearance so that there are no pinch points that may restrict or cut the airline. Secure the airline using the cable ties supplied by Link Mfg.

D. Tighten all plumbing fittings. Then, with the system at operating pressure (90 to 110 p.s.i.), open the Manual Shut-off Valve to supply air to the CABMATE. Check the system for air leaks.

E. Check for proper operation of the height control valve. Disconnect the valve linkage from the lever. Push the lever down 45°, air should flow into the air spring(s). Return the lever to the neutral position. Push the lever up 45°, air should exhaust from the air spring(s). Return the lever to the neutral position; no air should flow. Reconnect the valve linkage to the lever.

HEIGHT ADJUSTMENTS

Measure the design height of the air spring(s). The height should be 5 inches ± 1/16. To change the height, disconnect one end of the valve linkage and adjust accordingly.

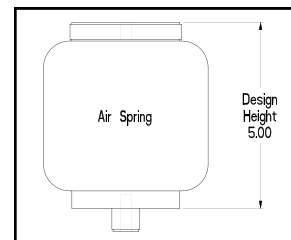

MAINTENANCE

CABMATES need no lubrication and little maintenance. The following components should be checked at the time the truck is being serviced. However, immediate corrective action should be taken if a serious malfunction occurs.

COMPONENT	POSSIBLE PROBLEM	CORRECTIVE ACTION	TORQUE
Airlines	Air leaks	Replace airline	Compression Nut Hand Tight + 1 Turn
Fittings	Air leaks	Remove fitting and apply fresh joint compound. Reinstall fitting, but Do Not Overtighten. Do not use teflon tape.	Threaded into: Metal 15 Ft. Lbs. Plastic Hand Tight + 1 Turn
Air Springs	A. Improper height B. Air leakage	A. Adjust valve linkage to maintain proper air spring height. B. Replace air spring.	Size Metal Plastic 3/8 25 Ft. Lbs 04 Ft. Lbs 1/2 28 Ft. Lbs 10 Ft. Lbs 3/4 30 Ft. Lbs 10 Ft. Lbs
Height Control Valve	Air spring(s) will not inflate when wheight is added to the cab; OR Air spring(s) will not deflate when wheight is removed from the cab.	A. Inspect valve to insure drive bearing notch is located on "SUSP" port side of valve. If not, loosen lever screw (but do not remove completely) and pull lever loose from drive bearing, rotate drive bearing until the bearing notch is in the correct position and resecure lever by tightening lever screw. B. Replace Valve	1/4 Mount Fasteners 10 Ft. Lbs. Bearing Screw 40-50 InLbs.
Shock Absorber	Insufficient dampening effect	Replace shocks	45 Ft. Lbs.
Lateral Control Rod	A. Loose nuts on lateral control rod bolts B. Worn bushings.	A. Tighten securely to clamp the inner sleeve. B. Replace lateral control rod.	40 Ft. Lbs.

IMPORTANT: Periodically check the tightness of all

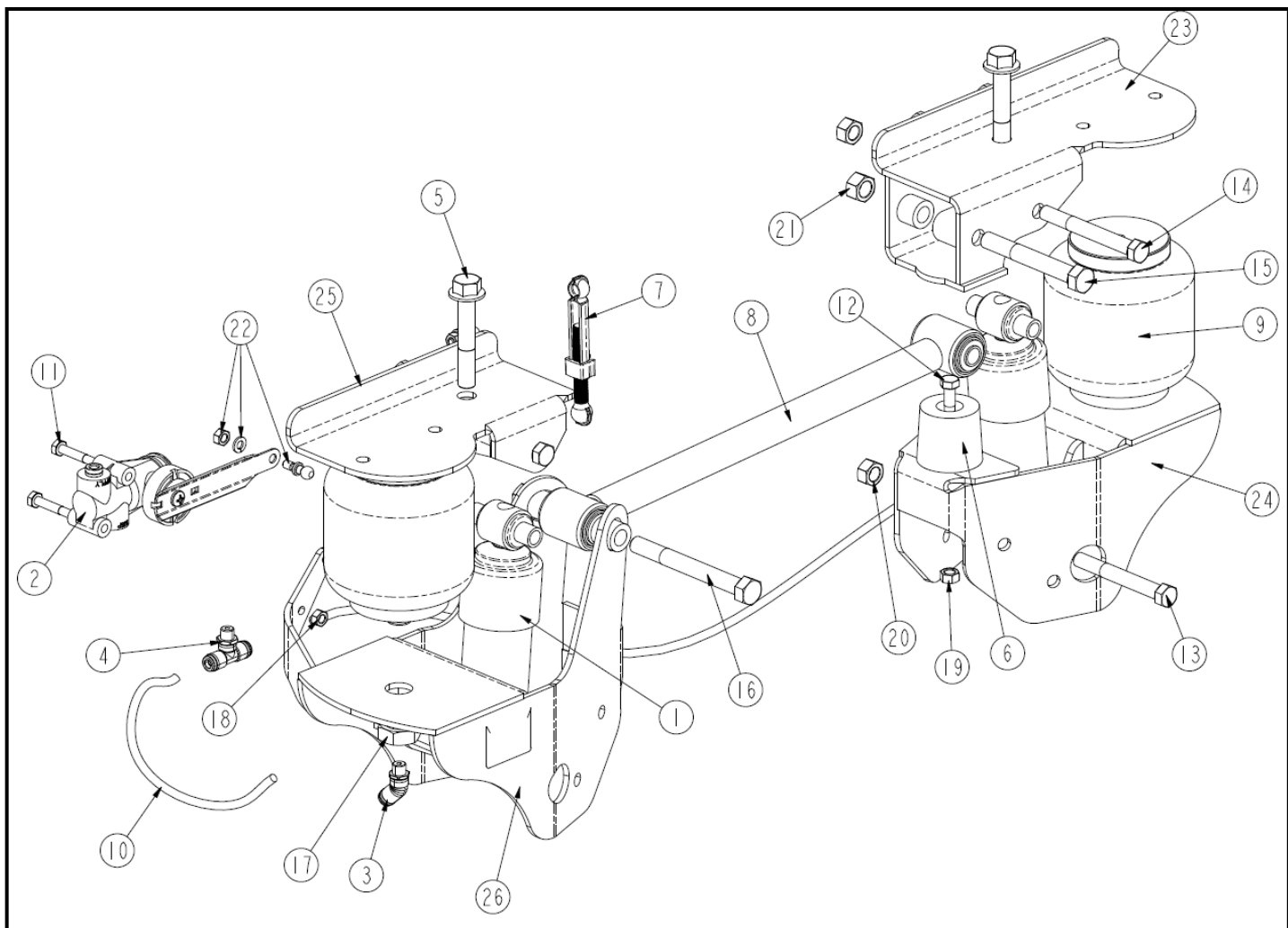

CABMATE® MODEL FH1322-A PARTS LIST

ITEM	PART NO.	DESCRIPTION	QTY	ITEM	PART NO.	DESCRIPTION	QTY
1	1201-1043	SHOCK ABSORBER	2	15	1404-1630	1/2 X 3 3/4 UNF HEX CAP SCREW (GRADE 8)	1
2	1350-0113	ASSEMBLY-HEIGHT CONTROL VALVE	1	16	1404-1636	1/2 X 4 1/2 UNF HEX CAP SCREW (GRADE 8)	1
3	13025202	ELBOW 45, 1/4 TB 1/8 M-NPT	2	17	1475-2400	3/4 UNF JAM NUT	2
4	13025206	BRANCH TEE, 1/4 TB 1/8 M-NPT	1	18	1476-0800	1/4 UNC HEX CENTER LOCK NUT (GRADE B)	2
5	1411-1624	1/2 X 3 UNC FLANGE BOLT (GRADE 8)	2	19	1476-1000	5/16 UNC HEX CENTER LOCK NUT (GRADE B)	1
6	1500-0070	BUMPER-JOUNCE, 1.75	1	20	1477-1400	7/16 UNF HEX CENTER LOCK NUT (GRADE B)	4
7	29910051	KIT-LINKAGE, MEDIUM	1	21	1477-1601	1/2 UNF HEX TOP LOCK NUT (GRADE C)	2
8	2993-2025	LATERAL CONTROL ROD	1	22	2991-0026	KIT-PIVOT BALL	1
9	1102-0023	AIR SPRING	2	23	2175-5001	BRACKET-MOUNT, CAB	1
10	1302-0090	0.250 AIRLINE	3.2'	24	2175-5003	BRACKET-MOUNT, CROSSMEMBER	1
11	1401-0814	1/4 X 1 3/4 UNC HEX CAP SCREW (GRADE 5)	2	23	2175-5005	BRACKET-MOUNT, CAB	1
12	1401-1012	5/16 X 1 1/2 UNC HEX CAP SCREW (GRADE 5)	1	24	2175-5006	BRACKET-MOUNT, CROSSMEMBER	1
13	1403-1428	7/16 X 3 1/2 UNF HEX CAP SCREW (GRADE 5)	2	-	1350-0000	PRESSURE PROTECTION KIT	1
14	1403-1430	7/16 X 3 3/4 UNF HEX CAP SCREW (GRADE 5)	2				